

Whirlpool

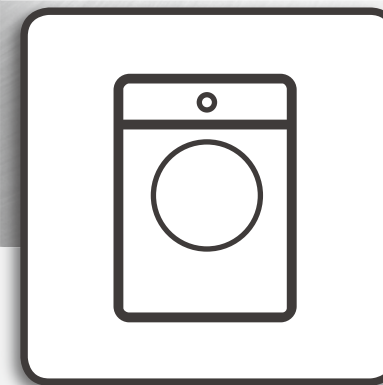

Health & Safety, Use & Care and Installation guide
產品安全指引、使用說明及安裝指南

Model 產品型號 : FRAL80111/FRAL80211/FRAL80411

Whirlpool® Registered trademark/TM Trademark of Whirlpool group of companies

All rights reserved - <http://www.whirlpool.com.hk>

註冊商標/惠而浦集團的TM商標

版權所有 翻印必究 - <http://www.whirlpool.com.hk>



Whirlpool

Before operating this washing machine,
please read these instructions carefully
and completely.

使用本機前，請先細閱產品說明書。





CONTENTS

SAFETY NOTICE	3~4
INSTALLATION INSTRUCTIONS	5~7
SPECIFICATION SHEET	7
NAME OF PARTS	8
DETERGENT DISPENSER BOX	9
INTRODUCTION TO THE CONTROL PANEL	10~11
PROGRAM CHART	12
PROGRAM INTRODUCTION	13
FUNCTIONS	14~15
FIRST-TIME AND DAILY USES	16
CLEANING AND MAINTENANCE	17
TROUBLESHOOTING	18~19
WARNING	38
AFTER-SALES SERVICE	39









SAFETY NOTICE

- To protect the user and other people's health and property, be sure to read and observe the following safety notice.













- The precautions stated here are classified as "Warning" and "Attention" according to the damage and the emergency caused by misoperation, and are described respectively in line with the marks below.

 Warning	Misoperation may cause death or GBH.
 Attention	Misoperation may cause body injury or damage the machine.

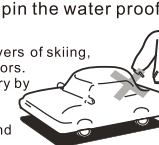
		
This mark indicates the content of warning or attention.	This mark indicates the prohibited action.	This mark indicates the compulsory action to be carried out.

 Warning	
<ul style="list-style-type: none"> ● Dismantling, repair or alterations should only be carried out by professional technician as otherwise you may be subjected to electric shock, may cause fire or injuries. 	<ul style="list-style-type: none"> ● This is equipped with a 3 pin plug which includes an earthing wire. This appliance must be earthed.  <p style="text-align: right;">Grounding</p>
<ul style="list-style-type: none"> ● Electricity supply must be unplugged with dry hands. Otherwise, this may cause electric shock.  <p style="text-align: right;">Wet hands Prohibited</p>	<ul style="list-style-type: none"> ● Please use the single socket with specific voltage and current which matches the marked specification. Avoid using extension leads, multiple sockets or adapters to prevent overloading.
<ul style="list-style-type: none"> ● Damaged or loosen wire or plug should not be used. Otherwise electric shock, short circuit or fire may take place. ● Do not damage wire. Do not damage or alter the wire by forcibly bend, pull, twist or handle the wire. Besides, please do not put weight on or trap the wire. Damage of wire may cause electric shock or fire.  <p style="text-align: right;">Prohibited</p>	<ul style="list-style-type: none"> ● Thoroughly wipe the power plug when dirt is adhering the prong or around the base of the prong. Clear Failure to do so may cause a fire.
<ul style="list-style-type: none"> ● Do not use water during maintenance and repair. This may cause short circuit or electric shock.  <p style="text-align: right;">Prohibited</p>	<ul style="list-style-type: none"> ● Washing machine should not be installed in humid places or in places exposed to wind and rain. Otherwise, electricity leak causing electric shock or fire may occur.  <p style="text-align: right;">Prohibited</p>
<ul style="list-style-type: none"> ● Do not place gasoline, benzine, alcohol, thinner or fabrics with these stains into or near to the washing machine. To prevent fire or explosion which may cause injuries.  <p style="text-align: right;">Prohibited</p>	<ul style="list-style-type: none"> ● This washing machine should not be placed near locations with candle, mosquito repellent incense, dog-end or other kinds of open flame. To avoid injuries caused by fire. ● Do not operate the machine when there is gas leak.  <p style="text-align: right;">Prohibited</p>

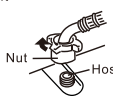
SAFETY NOTICE

<ul style="list-style-type: none"> Keep children away from the drum and do not place boxes or shelves next to the washing machine. Close the door to avoid children accidentally getting into the drum. <p>This appliance is not intended for use by persons (including children) with reduced physical, sensory or mental capabilities, or lack of experience and knowledge, unless they have been given supervision or instruction concerning use of the appliance by a person responsible for their safety.</p>  <p style="text-align: right;">Prohibited</p>	<ul style="list-style-type: none"> The glass door becomes hot in process of high-temperature washing. Do not touch the door when the machine is on. If you need to open the door during high-temperature washing, wait until the temperature drop to safe standard, and the door will unlock automatically. Packing materials may be dangerous to kids, please keep all packing materials (plastic bag, foam etc) far away from the kids.  <p style="text-align: right;">Prohibited</p>
<p>⚠ Attention</p>	
<ul style="list-style-type: none"> Do not pull the wire from the socket when unplugging the unit. To avoid electric shock or fire caused by short circuit.  <p style="text-align: right;">Prohibited</p>	<ul style="list-style-type: none"> Please unplug the unit when not using the unit for a long period of time. Electric shock or leakage may occur due to deformation of plastic parts of the unit. 
<ul style="list-style-type: none"> Electricity supply must be unplugged with dry hands during maintenance and repair. Otherwise, electric leakage causing injuries may occur. If the power cord or supply cord is damaged, it should be replaced by the manufacturer or its service agent or similarly qualified person in order to avoid a hazard. 	<ul style="list-style-type: none"> The hot water inlet temperature must not exceed 50°C. Electric shock or leakage may occur due to deformation of plastic parts of the unit.  <p style="text-align: right;">Prohibited</p>
<ul style="list-style-type: none"> Do not wash, rinse and spin the water proof fabric or cloth. e.g. Sleeping bag, raincoat, covers of skiing, utilities, bicycles, cars and motors. Otherwise this may lead to injury by abnormal vibration during spinning or damage the washing machine, wall, floor and clothes.  <p style="text-align: right;">Prohibited</p>	<ul style="list-style-type: none"> Do not stand on or put weight on the top of the unit. Otherwise, deformation and damage may result causing injuries. At least two people are required in moving or transportation.  <p style="text-align: right;">Prohibited</p>
<ul style="list-style-type: none"> Keep hands and feet away from the bottom of the unit when it is operating. Touching the ports beneath the unit may cause injuries.  <p style="text-align: right;">Prohibited</p>	<ul style="list-style-type: none"> Check water supply hose connection by turning on the water tap before washing. To prevent damages caused by possible water leakage due to loosen hoses. The new hose-sets supplied with the appliances are to be used and old hose-sets should not be reused. Do not block the ventilation openings at the bottom of washer by carpeting when the washer is installed on a carpeted floor.  <p style="text-align: right;">Water leakage</p>
<ul style="list-style-type: none"> Water supply hose should be tightly screwed to the unit. Failure to do so may result in water leakage. After prolonged usage, there may be water leakage caused by loosen union nut. So please check it frequently making sure the hose is screwed tightly.  <p style="text-align: right;">Water leakage</p>	<ul style="list-style-type: none"> Please turn off the water tap when not using the unit. To prevent damages caused by water leakage. 

INSTALLATION INSTRUCTIONS

Transportation

At least two people are needed to carry the machine. One person on one side carries the machine by holding the machine feet.

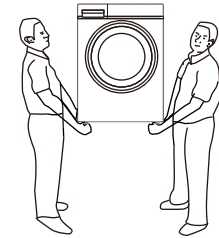

Location of washer



1. On the sloping ground
2. On the platform and the bracket
3. On a bumpy ground

Washing machine must be installed on the ground which must be hard, flat and skidproof. Please do not lay the washing machine on the soft blanket or wooden floor. It is forbidden to lay the washing machine on the platform or the bracket.

Remove the bolt used to fix the machine in transportation

To protect the machine in transportation, there are 4 bolts inserted into the inner part of the machine. Remove these bolts before use. (otherwise there will be strong shock, noise, and disfunction in spinning process.)

1. Unscrew the bolts that are fixed before transportation by spanner(4 bolts),
2. Remove the bolts horizontally.
3. Fit the lid into the holes.

- Installation should only be carried out by qualified technicians.
- Keep the dismantled bolts carefully, you will need them again when moving the machine to another location.

- As the picture shows, please be sure that the base protection device is not stuck at the bottom of the washing machine before use, otherwise it will affect the normal use of washing machine.

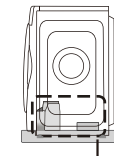
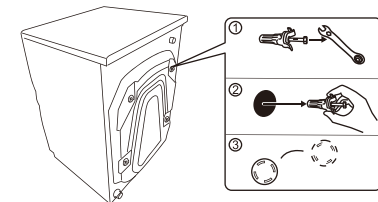

Base protection device

Adjust the machine horizontally

There will be strong shock, noise, and disfunction in operation if the washing machine is not steadily installed. Please adjust the front adjustable feet.

Methods are as follows:

1. Check whether the washer is on a level surface using a plumb line as shown in figure 1.
 - The washer is on level ground floor if the Frame line of washer is parallel with the plumb line.
2. Adjust the feet of washer if necessary to make the washer level as shown in figure 2.
3. Put your hands on the washer diagonally, press and shake the washer slightly to make sure that the washer is steady.

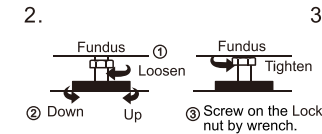
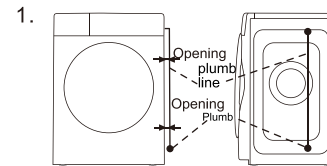

INSTALLATION INSTRUCTIONS

Connecting the Water Inlet Hose

Attaching the Joint to the Faucet

Type(the faucet month should be smooth)

Type A:The most appropriate.

Type B:The length of the faucet mouth needs to be at least 16mm.

Otherwise the joint cannot be installed.

Type C:It may cause water leakage.

CAUTIONS:

- Do not use water which is hotter than 50°C.
- If your faucet is not suitable, please replace with an appropriate one.



How to Attach the Joint

- Securely tighten the joint to secure the top of the joint to the faucet.
- Remove the CAUTION label from the joint.
- Turn the coupler on the joint clockwise to attach the hose securely to the top of the joint.

Connecting Water Inlet Hose to the Washer

Turn the nut clockwise till the nut is tight while holding the hose.

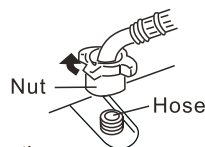

Turn the nut counterclockwise after turning the faucet off if you want to detach the water inlet hose.

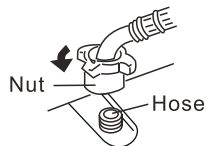

INSTALLATION INSTRUCTIONS

Connecting the Drain Hose

- When the machine is not in use, put drain hose at the back of machine (figure 1).
- When in operations, put drain hose into drainage duct (figure 2); you can also put end of drain hose into sewer, leaving space between end of drain hose and sewer elbow to avoid difficulty in draining water out of washing machine.
- Clean filter in pump periodically to keep washing machine working normally.

Note: Do not take off drain hose to avoid drainage problems.

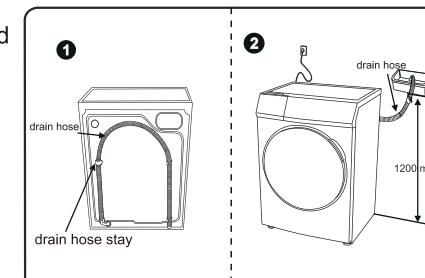

SPECIFICATION SHEET

Model	FRAL80111	FRAL80211	FRAL80411
Washing capacity	8.0kg	8.0kg	8.0kg
Max spin speed	1000rpm	1200rpm	1400rpm
Max current	10A	10A	10A
Rated voltage	220-240V/50Hz	220-240V/50Hz	220-240V/50Hz
Rated power	1800W	1800W	1800W
Water pressure	0.03-1.0MPa	0.03-1.0MPa	0.03-1.0MPa
Product dimension(WxDxH)	595x600x820(mm)	595x600x820(mm)	595x600x820(mm)

NAME OF PARTS

Attention

- We suggest the user to run the "DRUM CLEAN" program before the first wash.
- Don't forget to close the water tap and unplug the power supply when not in use to avoid any flood and fire disaster.

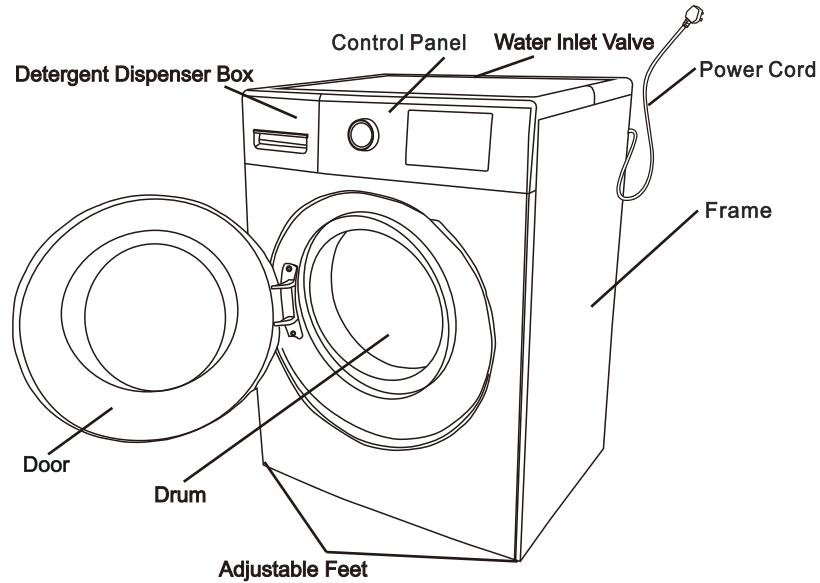

Accessories

Instruction manual	Water Supply Hose	Lid (4 pcs)	Spanner	Warranty Card

DETERGENT DISPENSER BOX

Powder detergents

- For undissolved detergents, for example: soap powder, dissolve it in advance, then pour into the case.

Liquid detergent and bleach

- Use low suds detergent for machine washing.
- For the concentrated liquid detergents, dilute it in advance, then pour into the case.

Fabric Softener

- Pour in additives before washing, it will be poured into drum automatically at the last round of rinsing process.
- For the concentrated detergents, dilute it in advance, then pour it into the case.
- Do not exceed to the full mark line.

Pre-wash detergents

- Detergents can be poured in this case for pre-washing.

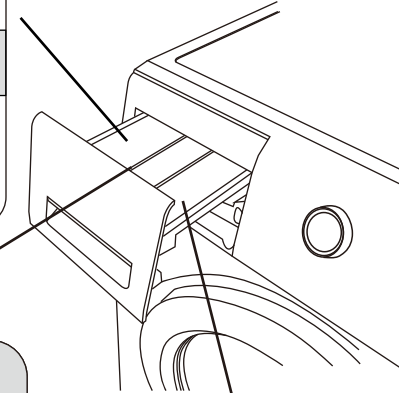

- Use the detergents in accordance with the instruction by its manufacturer.
- Excessive detergents will cause too much foams affecting washing performance, also create function faults.
- Choose suitable detergents in accordance with the type and color of clothes, the water temperature and the stain.

INTRODUCTION TO THE CONTROL PANEL

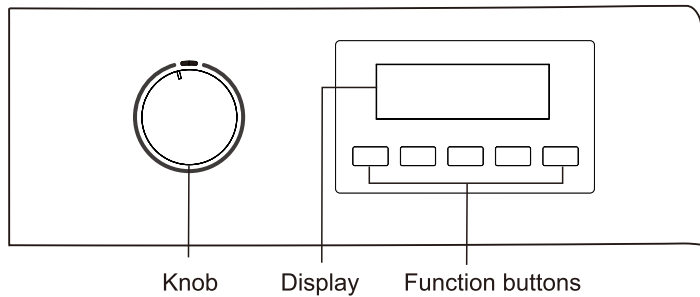

■ Start/Pause button

- Press button once to start and press again to pause.



■ On/Off

- Turn the knob to switch on the machine. When the knob is in OFF position the machine will be switched off.

■ Knob

- Choose a suitable program according to fabric type and dirt level .

■ Display

- When power is turned on, it will display the spin speed and other functions.
- When machine is in operation, it will display the time remaining.
- When failure occurs, it will display the error code .

■ Temp button

- Set the washing temperature according to the fabric type.
- The temperature setting range is different among programs.

INTRODUCTION TO THE CONTROL PANEL

■ Speed button

- Set the spin speed by pressing this button.
- The spin speed setting range is different among programs.

■ Delay button

- Press this button to set a delayed finish for selected program in between 1-24 hours.

■ Rinse button

- Select this option for enhanced rinsing efficiency by adding up to 6 rinses.
- Adjust the number of rinses in some programs is limited.

PROGRAM CHART

Maximum load 8 kg						Detergents and additives		
Program	Available temperatures	Max. spin speed (rpm)	Max. load for wash cycle (kg)	Default wash cycle duration (hh:mm)	Rinse Option	Prewash	Main	Softener
						1	2	3
MIXED 60'	❄ - 60°C	max.	6	1:00	✓	-	●	○
PURECARE+	40°C	1000/1200 [†]	3	2:09	-	-	●	○
COLOURS 15°	15°C	800	3	0:57	✓	-	●	○
SPEED 15'	❄ - 30°C	max.	1	0:15	✓	-	●	○
COTTON (2)	❄ - 90°C	max.	8	1:46 [*]	✓	-	●	○
⊖ COTTON (1)	❄ - 60°C	max.	8	3:44 ^{**}	✓	-	●	○
COTTON \sqcup	❄ - 90°C	max.	8	2:02 ^{***}	✓	●	●	○
SYNTHETICS (3)	❄ - 60°C	max.	6	1:26 ^{****}	✓	-	●	○
DELICATES	❄ - 40°C	600	3	0:52	✓	-	●	○
WOOL/HAND	❄ - 40°C	800	2	1:02	✓	-	●	○
JEANS	❄ - 40°C	1000/1200 [†]	5	1:04	✓	-	●	○
DUVET	❄ - 60°C	1000/1200 [†]	5	1:19	✓	-	●	○
RINSE & SPIN	-	max.	8	0:19	✓	-	-	○
SPIN & DRAIN	-	max.	8	0:10	-	-	-	-
DRUM CLEAN	90°C	800	-	1:37	-	-	○	-

● Required dosage ○ Optional dosage

* For FRAL80111 model, the default wash cycle duration is 1:44. For FRAL80211 model, the default wash cycle duration is 1:45.

** For FRAL80411 model, the default wash cycle duration is 3:41.

*** For FRAL80111 model, the default wash cycle duration is 2:00. For FRAL80211 model, the default wash cycle duration is 2:01.

**** For FRAL80111 model, the default wash cycle duration is 1:24. For FRAL80211 model, the default wash cycle duration is 1:25.

[†]For FRAL80411 model, the max. spin speed can be selected is 1200 rpm.

For wash programmes with temperatures above 50°C, we recommend using powder detergent rather than liquid, and following the directions given on the detergent package.

For all Test Institutes

1) "E COTTON" program is the reference program for the energy label. Set this wash cycles with a temperature of 40°C or 60°C. They are the most efficient program in terms of energy and water consumption for washing normally soiled cotton laundry. The actual water temperature may differ from the declared one.

2) Long cotton programme: set the "COTTON" program with a temperature of 40°C.

3) Synthetic program along: set the "SYNTHETICS" program with a temperature of 40°C.

The cycle duration indicated on the display or in the manual is an estimated time calculated for standard conditions. The actual cycle may vary in relation to a number of different factors, such as inlet water temperature and pressure, ambient temperature, quantity of detergent, size and type of load, load balancing and any additional optional functions selected.

6th Sense - the sensor technology adapts water, energy and program duration to your wash load.

PROGRAM INTRODUCTION

Follow the instructions on the symbols of the garment's wash care label. The value indicated in the symbol is the maximum recommended temperature for washing the garment.



MIXED 60'	Mix wash of cotton, linen, synthetic and mixed fibres.
PURECARE+	For removal of various stubborn stains on cotton, linen, synthetics and mixed fibres.
COLOURS 15°	This cycle helps protect colours by washing in cold water (15°C), offering wash results comparable to 40°C.
SPEED 15'	Wash of lightly soiled garments quickly in 15 minutes.
COTTON	Wash of heat resistant cotton or linen fibres.
E COTTON	The most efficient program in terms of water and energy consumption.
COTTON \sqcup	Wash of cotton and linen fibres with a prewash phase. We recommend adding detergents both, in the prewash and main wash sections.
SYNTHETICS	Wash of normally soiled synthetic fibres.
DELICATES	Wash of clothes which are particularly delicate e.g. silk, satin.
WOOL/HAND	Wash of wool garments which can be washed by machine. Turn garments inside-out before washing.
JEANS	Wash of jeans. Turn garments inside-out before washing.
DUVET	Wash of eiderdown padded items. e.g. duvets, cushions, anoraks. We recommend to fold edges inwards and to use no more than 3/4 of the total drum volume.
RINSE & SPIN	For clothes which require only rinse and spin
SPIN & DRAIN	To spin laundry and drain the water.
DRUM CLEAN	For cleaning the drum. It must be run without any load in drum. We recommend running it every 40 normal wash cycles.

FUNCTIONS

Delay Finish

Setup

- Turn on machine and select the desired wash cycle.
Press the Delay button to set a delayed finish for the cycle.
Press the Start/Pause button to start-up the delay wash function.
(Delay finish period can be set in between 1-24 hours.)

Attention

- If users need to amend the set delay time, please switch off and restart the machine.
- After selection, users can cancel it by switching off and restarting the machine.
- Once delay finish has been confirmed, press the Delay button. The set time will be displayed for 5 seconds.
Delay finish duration differs based on water pressure, laundry load, fabric type, water temperature.

Cancel Buzzer Sound

There is no buzzer when cycle ends.

Setup

Turn on machine and press Start/Pause button till buzzer sounds. When button is released, the buzzer sound will be deactivated. To reactive, repeat steps.

CHILD PROTECTION

If machine door is opened before program starts the machine will activate the child protection function automatically when in operations. Firstly, the door will be locked and motor will be running for a while. If the door is opened during this period of time, the machine will stop operation automatically.

CHILD LOCK

User can activate the child lock function in order to prevent children from accidentally touching the control panel and machine during operation. Both the door and all buttons(except On/Off) will be locked automatically. Door will be unlocked once this function has been deactivated.

Setup

Turn on machine and press Rinse button for 3 seconds till buzzer sounds. The child lock function is activated. Repeat steps to deactivate.

FUNCTIONS

Door Lock and Unlock

DOOR LOCK

When the machine is in operation, the door locks automatically. It can't be opened. The door locked indicator  will lit on display.

DOOR UNLOCK

When the machine is working, press the Start/Pause button.

The door can be unlocked and opened when the door locked indicator  is off.

- If power plug is removed directly or if there is a power cut when the machine is in operation, the door can't be unlocked automatically.
- If door is opened when the machine is in operation, the foam may spillover. Clean with towel thoroughly.
- The user can't open the door when the machine is running with a high temperature, or when water temperature is high.

FIRST-TIME AND DAILY USES

First-Time Use

Once the machine has been installed, and before you use it for the first time, run a wash cycle with detergent and no laundry, using the "DRUM CLEAN" cycle(90°).

Daily Use

1. Preparation of laundry
- Load the clothes in and close the door.
- Put the detergent or washing powder into the relevant compartments.
- Switch on the water tap, connect the drain-pipe, plug the power supply.
2. Switch on the machine.
3. Select the desired program.
4. Select the desired functions.
5. Press the Start/Pause button.
6. When cycle ends, the buzzer will sound.

Daily Use of the WOOL Program

- Turn on machine and select the "WOOL" program.

Attention

- Please confirm the wash care label on the clothes before washing.
- When cycle ends, please take the clothes out immediately for airing in order to avoid fabric deformation.
- The temperature can't be more than 40°C to avoid spoiling the fabrics.
- We recommend using special detergents for better washing performance.
- Separately wash light colour clothes and dark colour clothes.

CLEANING AND MAINTENANCE

- Proper cleaning and maintenance can prolong the lifespan of machine.
- Please unplug the power supply during all cleaning and maintenance.

MACHINE BODY

- Please use a soft cloth to clean the body after washing every time. If there is too much dirt, please apply some detergent or soap water on the cloth to clean the body.
- Please don't use water to flush the machine directly.
- Dirty powder, diluent, petrol and alcohol are forbidden for use in cleaning.

DOOR BELLOW

Please use cloth to clean the bellow after washing every time, to remove any stain and dirt.

DETERGENT DISPENSER BOX

Please clean the detergent dispenser box periodically. Remove the box and clean it with water.

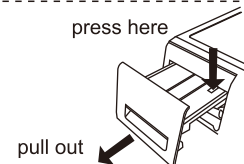

INLET VALVE (RECOMMENDED ONCE EVERY SIX MONTHS)

1. Close the water tap and unscrew the hose.
2. Take out the mesh filter.
3. Use a toothbrush to clean the mesh filter and then assemble it again.
4. Connect the inlet hose after cleaning.



DRUM CLEANING(RECOMMENDED EVERY 40 WASH CYCLES)

There may be dirt residue inside the drum after prolonged usage. We recommend running the "DRUM CLEAN" cycle with no laundry after every 40 wash cycles.

CLEANING PUMP FILTER (RECOMMENDED MONTHLY)

1. Insert coin into the groove of pump and press it. The filter cover can be opened. (Attention: If hot wash program has been used, please wait for water to cool down before opening the filter).
2. Remove the filter in an anticlockwise direction.
3. Wash the filter with water.
4. Assemble the filter into the pump in a clockwise direction.

Attention: 1. The filter should be assembled tightly in order to avoid water leakage.
2. Please do not clean the filter when the machine is in operation.

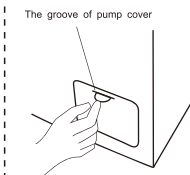

TROUBLESHOOTING

Anomalies	Possible Reason/Solution
Door cannot be opened	<ul style="list-style-type: none"> Water temperature is too high or power failure. Child lock activated. The clothes are trapped between door and bellow.
Peculiar smell in drum	<ul style="list-style-type: none"> The machine requires a service wash. Run the "DRUM CLEAN" cycle.
The machine does not fill with water	<ul style="list-style-type: none"> Ensure the water tap is turned on. Ensure water filter is not blocked.
Water is being drained during wash cycle	<ul style="list-style-type: none"> Too much detergent was used.
Display changes estimated "Time to End" during operation	<ul style="list-style-type: none"> The display time is for guidance only, it is not a precise time to finish and may vary.
Abnormal sound during spinning	<ul style="list-style-type: none"> The machine is not plugged into socket fully. The transport bolts have not been removed correctly during installation. Small objects such hairpin, coins are trapped in the drum.
Power failure occurs	<ul style="list-style-type: none"> To restart the machine after a power failure, turn the knob to switch on the machine again.
Opening door manually	<ul style="list-style-type: none"> During power failure or appliance failure, the door remains locked. To open the door and unload laundry, unplug the power cord and wait for the inner drum to stop before pulling down the emergency rope located at the button right corner of the front door manually before you can open the door. Confirm that water level is below the bottom of the door and water temperature is below 60°C before opening the door.

TROUBLESHOOTING

Error Code	Reason	Inspection factors	Solution
No display	Out of operation	<ul style="list-style-type: none"> Whether the outlet have electricity Whether the plug is plugged in Whether there is a power failure Whether the fuse has blown in the mains plug 	
E11	No water	<ul style="list-style-type: none"> Whether water tap is turned on Whether filter has any blockage Whether there is a water supply 	Inspect and solve problem accordingly, then press the Start/Pause button to restart operation.
E12	Draining failure	<ul style="list-style-type: none"> Whether drain pipe is in the right place Whether drain pipe is placed too high Whether there is blockage in drain pipe 	Inspect and solve problem accordingly, then press the Start/Pause button to re-start operation.
H	Door cannot be opened	<ul style="list-style-type: none"> Make sure water has cooled down before attempting to open the door. 	Door unlocks automatically once water temperature has dropped to safe range
U3	Spinning function does not work	<ul style="list-style-type: none"> Ensure the machine is level. Avoid overloading with few single heavy items. Avoid rolling blanket up into machine. 	Rearrange the load adding 2-3 small garments and press Start/Pause button to re-start operation.
U4	Door not closed		Close the door, wait for door locked indicator light to be activated before pressing the Start/Pause button to continue operation.
Other code	Alarm sounds		Press Start/Pause button to resume operation. If problem persists, contact the After-Sales Service.

索引









安全指引	21~23
安裝指引	23~25
技術參數	25
洗衣機介紹	26
洗滌劑盒	27
控制面板	28~29
程序表	30
洗衣程序	31
功能	32~33
首次及日常使用	33~34
清潔和保養	34~35
故障排除	36~37
警告	38
售後服務	39

安全指引

- 使用前請詳細閱讀此安全指引並正確使用本機。
- 為了防止對您和他人造成傷害或財產損壞，現就安全方面需要務必遵守的事項，作如下說明：

 警告	此標示欄的內容為【有死亡或受傷的可能性】
 注意	此標示欄的內容為【有受傷及物品損壞的可能性】

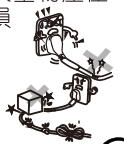
		
「注意」事項	「禁止」事項	「警告或提醒注意」的內容

 警告	
 不可改裝洗衣機。 <ul style="list-style-type: none"> • 會造成火災、觸電、受傷。 • 發生故障時請聯絡售後服務中心。 	 請務必正確接地。 <ul style="list-style-type: none"> • 以防止漏電事故的發生。 
手濕時請勿插入或拔下電源線插頭。 <ul style="list-style-type: none"> • 以避免觸電的危險。 	 不可使用220V以外的電壓。 <ul style="list-style-type: none"> • 會造成損壞/火災及觸電危險。 • 勿使用萬能插座或與其他電器共用電源。
<ul style="list-style-type: none"> • 電源線及電源線插頭損壞或鬆動時請勿使用。 • 使用時請注意電源線外皮是否損傷，有無不合理彎曲或拉伸及重物壓住變形等現象，電源線破損導致絕緣不良，這是發生觸電、火災的原因。如果電源軟線損壞，為了避免危險，必須由製造商、其維修部或合資格的技術人員進行更換。 	 電源線插頭的灰塵要定期清理。 <ul style="list-style-type: none"> • 電源線插頭上若聚積灰塵，會因濕氣造成絕緣不良引起火災。 避免安裝洗衣機於潮濕及雨淋處。 <ul style="list-style-type: none"> • 以避免因漏電而導致觸電或火災。 

安全指引

警告

洗衣機本體各部件，請勿直接用水沖洗。

- 以避免觸電的危險。



- 請勿靠近煙火，且勿將點燃的蠟燭、香煙、蚊香及其他火源放在洗衣機的附近，這是造成火災的主要原因。



請勿清洗沾有揮發性溶劑的衣物。

- 請勿清洗沾有汽油、煤油、稀釋劑等的衣物。這樣可能引起火災或爆炸。



不要讓兒童在洗衣機上或洗衣筒內玩耍，當未使用時請關好機門。

- 如果兒童不慎掉入洗衣筒內，會產生嚴重的傷害。



本電器用品並非設計給身體、感覺或心智功能不足者（包括孩童），或缺乏經驗及知識者使用。除非有能確保其安全者給予監督或指導，才能使用本產品，以避免引起火災或導致受傷。

注意

- 當插入或拔出電源線插頭時，手指須緊握插頭絕緣部分施力，請勿觸碰插頭的金屬插片，以避免觸電或施力於導線端，導致電源線內部導線斷裂。



- 洗衣機不使用时，應將電源線插頭拔掉，以防止發生火災或其他事故。

請勿連接50°C以上的熱水水源。



進行任何清潔和保養時，請務必從插座拔下電源線插頭，此外，手濕時不可插拔電源線插頭。

- 會造成觸電、受傷。

請勿將重物放置在洗衣機上。

- 以避免部件變形或破損導致危險的發生。



防水性或不吸水的衣物不可以放入洗衣機內清洗。

- 以避免洗衣或脫水時，產生異常振動。（如：雨衣、車套）

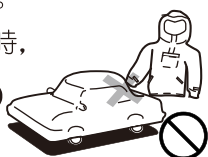

- 進行洗滌前請先打開水龍頭，以確保進水管不漏水。

- 使用跟機配備的全新喉管。切勿使用二手喉管。

- 如果將本機放在地毯上，請調整機腳，以便在本機下方留出足夠的通風空間。

安全指引



使用前請固定好排水管，並確保水管已連接好。

避免脫水異常發生。

經過長期使用後，軟管螺帽或會有鬆脫跡象，從而導致漏水情況發生。請定期檢查所有喉管。

洗衣機不使用或進行任何清洗和保養時：

- 應關閉水龍頭，以避免進水軟管破損或脫落，造成漏水事故的發生。



安裝指引

搬運

搬運時，務必由兩個人進行。在機體兩側分別手握洗衣機機腳進行搬運。

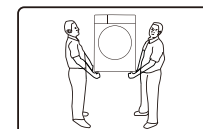

正確放置洗衣機

洗衣機須安裝在地面上或專用洗衣機底座上，地面必須堅固、平坦且防滑，切勿將洗衣機放置在地毯或木質地板上。禁止將洗衣機放在除洗衣機專用底座外的地臺及支架上。

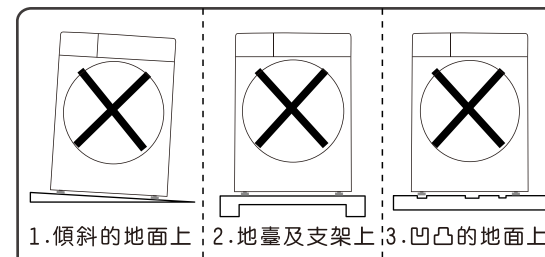

1. 傾斜的地面上 2. 地臺及支架上 3. 凹凸的地面上

拆除運輸固定用螺栓及底座保護裝置

- 為在運輸時保護洗衣機，洗衣機背面裝有4個運輸固定用螺栓，使用之前須將其全部拆除。（否則，洗衣機在脫水時會出現強烈振動、噪音及功能異常）

1. 用工具擰鬆運輸固定螺栓（4個）。
 2. 將螺栓左右晃動後拔出。
 3. 使用提供的塑膠蓋對準孔的位置按進去，直到吻合為止。
- 產品的安裝須由合資格的技术人員進行。
 - 請妥善保管好拆卸下來的運輸固定用螺栓，如果需要將本機移到另一個地方，您將再次需要使用它們。
 - 使用前務必確認如圖所示的底座保護裝置未卡在洗衣機底部，否則將影響洗衣機的正常運作。

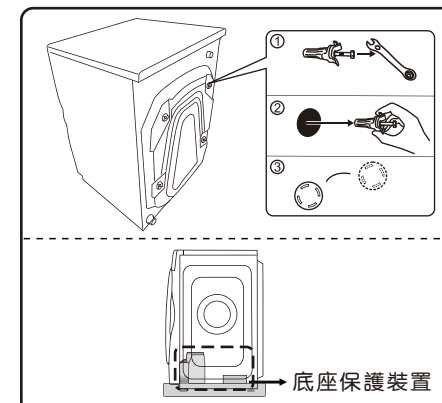

安裝指引

■ 水平放置洗衣機

- 洗衣機安裝不平，使用時可能會發生異常噪音、振動或功能異常。請調節可調節機腳，使本機水平放置：
 1. 用工具沿順時針方向鬆開洗衣機底部機腳的螺帽，轉動機腳可以調節高度，水平放置本機。
 2. 使用水平儀檢查洗衣機的調準狀態，確保正確調平本機。
 3. 用工具逆時針將螺帽擰緊，鎖定機腳。
 4. 調整好後，用兩隻手分別按洗衣機上蓋的對角，稍稍用力按壓、晃動，以確認洗衣機水平放置。

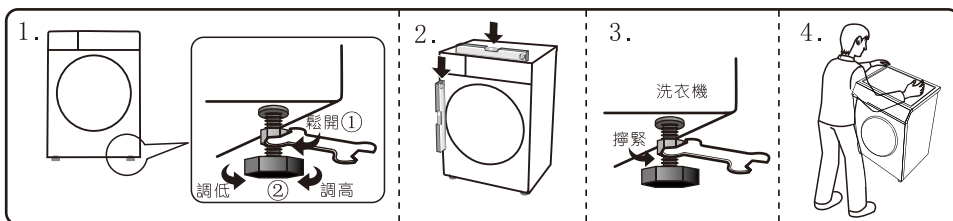

■ 進水軟管的連接

注意：請務必使用跟機配備的全新喉管，舊進水軟管不能重複使用。

水龍頭類型：（水龍頭口要平整）

A型：最為合適。

B型：水龍頭長度須大於16mm，否則無法安裝進水管。

C型：如圖所示部位可能會出現漏水現象。

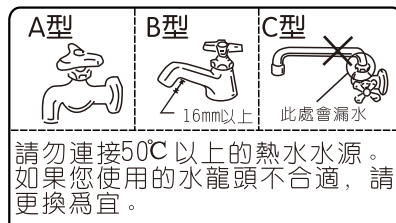

1. 將進水管接頭牢固連接水龍頭。
2. 撕下進水管接頭上的封條。
3. 將進水軟管與進水管接頭連接。
4. 將進水軟管與洗衣機側進水閥口連接。
 - 將進水管口對準進水閥口，順時針旋轉進水軟管上的旋緊螺帽，直至旋不動為止。
5. 確認進水軟管已正確連接：
 - 向下拉扯進水軟管並確認螺帽與進水閥已擰緊，然後慢慢打開水龍頭，檢查是否漏水。如果漏水，請關閉水龍頭，按以上步驟，重新安裝。

安裝指引

■ 排水軟管的連接

1. 當未使用洗衣機時請將排水管放在洗衣機背後。
 2. 當使用洗衣機時，請將排水管放入排水池，也可將排水軟管另一端插入下水道口內，令排水軟管口與下水道彎管之間保持距離，以免影響排水。
 3. 定期清理水泵過濾器可以保持洗衣機正常運行。
- 注意：在安裝機器時，排水管固定卡扣請勿下掉，否則將造成排水故障。

技術參數

型號	FRAL80111	FRAL80211	FRAL80411
最大洗衣量 (公斤)	8.0	8.0	8.0
最高脱水轉速 (轉/分鐘)	1000	1200	1400
電流 (安倍)	10	10	10
電壓 (V/Hz)	220~240/50	220~240/50	220~240/50
水壓 (MPa)	0.03~1.0	0.03~1.0	0.03~1.0
產品尺寸 (闊x深x高) (毫米)	595x600x820	595x600x820	595x600x820

洗衣機介紹

■ 注意

- 首次使用之前，建議在沒有衣物的情況下運行一次「清潔滾筒」程序。
- 每次使用後，請關閉水龍頭，拔下電源插頭，防止意外的水災和火災發生。

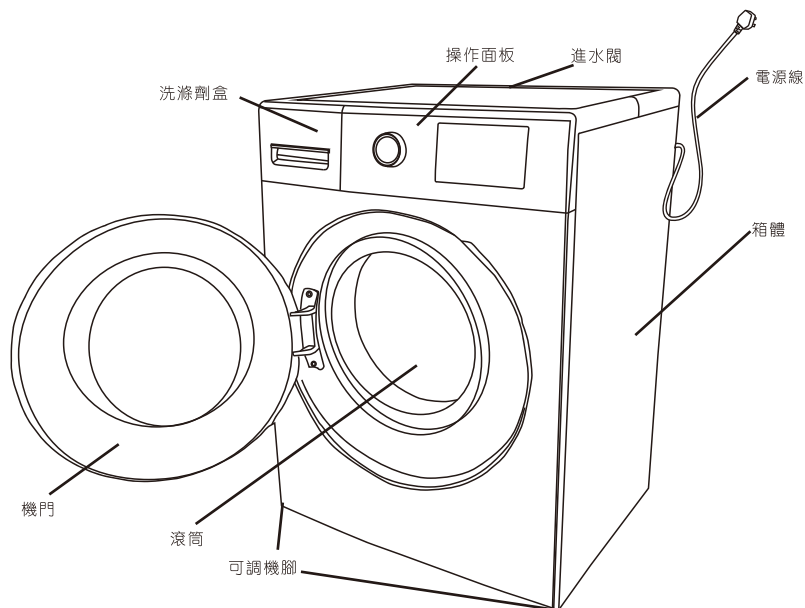

■ 洗衣機附件

使用說明書	進水軟管組件	運輸螺栓 塑膠蓋 (4個)	扳手 工具	產品保用證

洗滌劑盒

洗衣粉

- 不易溶解的，如粉狀皂片，請預先充分溶解後倒入洗衣粉隔間內。

洗衣劑

- 使用低泡配方的洗衣機適用洗衣劑。
- 使用濃縮型洗衣劑，請用相應比例的水稀釋後倒入。

柔順劑

- 請在洗滌前放入，將在最後一次過水時自動注入。
- 使用濃縮型柔順劑，請用相應比例的水稀釋後倒入。

預洗用洗衣劑

- 當使用預洗功能時，請在此格加入洗衣劑。

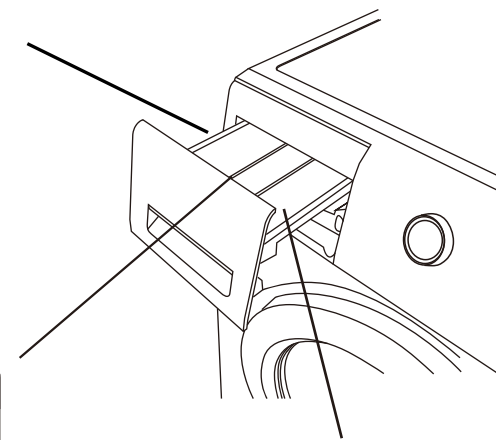

- 使用適用於洗衣機的洗衣劑。
- 請勿使用過量的洗滌劑，以免產生過多泡沫，影響洗滌效果，或可能導致功能故障。
- 請按照洗衣劑包裝上的說明，並根據所洗衣物種類、顏色、水溫、污漬程度等使用合適的洗衣劑。

控制面板

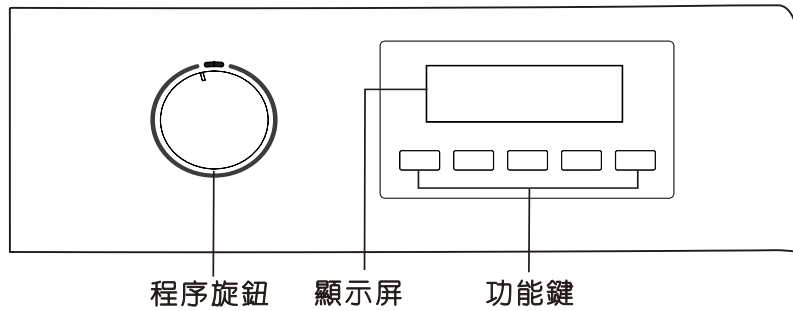

■ 啟動/暫停鍵

- 按下此鍵啟動洗衣程序，再次按下此鍵暫停程序。



■ 開/關

- 轉動旋鈕以開機，將旋鈕轉至OFF位置即可關機。
(程序結束後，洗衣機將自動關機。)

■ 程序旋鈕

- 根據洗滌衣物的種類及污漬程度選擇合適的程序。

■ 顯示屏

- 接通電源時，顯示脫水轉速等數值。
- 於程序運行時顯示剩餘時間。
- 發生異常時，顯示故障代碼。

■ 溫度鍵

- 根據洗滌衣物的種類選擇洗滌溫度。
- 每個程序均會有預設的洗滌溫度範圍。

控制面板

■ 脫水轉速鍵

- 根據需要設定脫水轉速。
- 每個程序均會有預設的脫水轉速。

■ 預校結束時間鍵

- 設定延遲當前程序完成的時間，可設定1-24小時的時間。

■ 額外過水鍵

- 按下此鍵可增加過水次數達最多共6次，更徹底去淨洗衣劑殘留。
- 個別程序可設定之額外過水次數或會有所不同。

程序表

最大負載量8公斤						洗衣劑和添加劑		
程序	溫度 (°C)	最高脫水轉速(轉/分鐘)	最大洗衣量(公斤)	預設程序時間(小時:分鐘)	額外過水	預洗	主洗	柔順劑
						1	2	3
60'混合洗	✿ -60°C	max.	6	1:00	✓	-	●	○
高效去漬+	40°C	1000/1200 [#]	3	2:09	-	-	●	○
護色15°	15°C	800	3	0:57	✓	-	●	○
15'極速洗	✿ -30°C	max.	1	0:15	✓	-	●	○
棉質 (2)	✿ -90°C	max.	8	1:46*	✓	-	●	○
e棉質節能洗 (1)	✿ -60°C	max.	8	3:44**	✓	-	●	○
棉質+預洗 ▽	✿ -90°C	max.	8	2:02***	✓	●	●	○
合成纖維 (3)	✿ -60°C	max.	6	1:26****	✓	-	●	○
纖細衣物	✿ -40°C	600	3	0:52	✓	-	●	○
羊毛/手洗	✿ -40°C	800	2	1:02	✓	-	●	○
牛仔布	✿ -40°C	1000/1200 [#]	5	1:04	✓	-	●	○
大型衣物	✿ -60°C	1000/1200 [#]	5	1:19	✓	-	●	○
過水及脫水	-	max.	8	0:19	✓	-	-	○
脫水及排水	-	max.	8	0:10	-	-	-	-
清潔滾筒	90°C	800	-	1:37	-	-	○	-

● 需要使用洗衣劑 ○ 選擇性使用洗衣劑

* 對於FRAL80111型號，預設程序時間為1:44；對於FRAL80211型號，預設程序時間為1:45。

** 對於FRAL80411型號，預設程序時間為3:41。

*** 對於FRAL80111型號，預設程序時間為2:00；對於FRAL80211型號，預設程序時間為2:01。

**** 對於FRAL80111型號，預設程序時間為1:24；對於FRAL80211型號，預設程序時間為1:25。

對於FRAL80411型號，可調整的最高脫水轉速為1200轉/分鐘。

若使用溫度高於50°C的程序，建議使用洗衣粉，並按照洗衣粉包裝的指示使用。

能源標籤測試程序

1) 「棉質節能洗」程序為能源標籤參考程序。設定溫度為40°C或60°C。用於洗滌一般骯髒棉質衣物的標準程序，它是在結合水和能源消耗方面上最有效的程序。實際水溫可能與預設指定洗衣程序的溫度有所不同。

2) 較長的棉質程序：使用40°C的「棉質」程序。

3) 合成纖維程序：設定「合成纖維」的洗衣程序溫度為40°C。

在顯示器上或說明書中的程序時間是以標準的情況下計算，實際程序時間會因不同的因素自動調整，如進水溫度和水壓，環境溫度，洗衣劑量，衣物的類型，負載平衡及附加選項等。

第6感智能感應 - 智能感測調控技術可通過水流，節能和負載量而調節程序時間。

洗衣程序

請根據衣物上的護理標籤指示及合適的洗衣溫度，選擇合適的程序於您的衣物種類。



60'混合洗	適用於棉質及合成纖維的混合洗滌。
高效去漬+	適用於非常骯髒的棉、麻、合成纖維衣物，去除各種頑固污漬。
護色15°	此程序將衣物使用冷水(15°C)洗衣，幫助保護衣物顏色，以可提供的效果對比，只需15°C水溫，便可達40°C的潔淨效能。
15'極速洗	適用於輕微骯髒衣物的洗滌。
棉質	適用於棉質衣物的洗滌。
e棉質節能洗	此程序是在60°C水溫下清洗棉質衣物的最佳耗水和耗電程序。屬能源標籤的參考程序。
棉質+預洗 ▽	選擇此程序會在主洗前加入預洗過程，以洗滌棉質衣物。建議於預洗和主洗格內，一併添加洗滌劑。
合成纖維	適用於一般骯髒的人造纖維衣物，例如（滌綸、膠綸黏、纖維等）或混棉織物。
纖細衣物	適用於質料纖細的衣物。建議洗衣前先把衣物內部反出來。
羊毛/手洗	適用於可機洗的羊毛類衣物洗滌。
牛仔布	適用於牛仔類衣物的洗滌，建議洗衣前先把衣物內部反出來。
大型衣物	適用於非常骯髒的毛毯或大件衣物的洗滌。
過水及脫水	過水及脫水程序。
脫水及排水	脫水及排水程序。
清潔滾筒	適用於清潔滾筒，運行程序時請將所有衣物移走。建議運行約40次洗衣程序後，進行一次「清潔滾筒」程序。

功能

預校結束時間

設定

- 開機後選擇合適程序，並按下「預校結束時間」鍵延遲程序完成，按「啟動/暫停」鍵啟動預校結束時間功能。
(預校結束時間以1小時為間隔，可設置1-24小時)

注意

- 如需變更已設定的結束時間，請重新開機以再次設定。
- 要取消已設定的結束時間，請先關閉洗衣機並重新開機。
- 完成設定後，請按一下「預校結束時間」鍵，預約的時間會顯示5秒。
- 預校結束時間可能會隨着水壓、衣物負載量、衣物的種類、水溫等條件不同而與實際結束之時間有差別。

取消程序結束提示音

程序結束後不發出提示音。

設定

開機後按住「啟動/暫停」鍵，直到蜂鳴聲響起後鬆開按鍵即可。要重新啟動功能，重複上述步驟。

兒童保護功能

洗衣機機門關閉後，程序運行前，如果偵測到機門被打開過，程序在運行時將執行兒童保護功能：首先，機門會被鎖定，然後洗衣機會在短暫運行後停止，門鎖解鎖，等待一定時間後上鎖繼續運行。

兒童安全鎖

爲了防止兒童在洗衣機運行時錯誤操作洗衣機，可以設置兒童安全鎖，使機門無法打開，所有按鍵(除電源開/關外)鎖定。解除兒童安全鎖後方可開門。

設定

開機後，按「額外過水」鍵3秒，直到蜂鳴聲響起後鬆開即可。要取消功能，重複上述步驟。

功能

機門上鎖及解鎖

機門上鎖

洗衣機運行時，機門將自動鎖定，無法打開，「門鎖提示燈」將會亮起。

機門解鎖

運行過程中，按下「啟動/暫停」鍵，當「門鎖提示燈」熄滅後，機門可以打開。

- 直接拔下電源插頭或洗衣機中途停電，並不會令機門門鎖自動解除。
- 在洗滌過程中開啟機門，可能有泡沫溢出，請用毛巾清潔滾筒周邊範圍。
- 在高溫運作狀態下無法打開機門。

首次及日常使用

首次使用

完成安裝洗衣機，並且在您第一次使用它之前，請在沒有衣物的情況下，使用(90°C)的「清潔滾筒」程序，並加入洗衣劑運行一次程序。

日常使用

1. 準備洗滌。
 - 放入衣物並關上機門。
 - 將洗滌劑(及添加劑/柔順劑)放入相關的容器隔間內。
 - 打開水龍頭，連接好排水管，插入電源插頭。
2. 轉動程序旋鈕開機。
3. 根據需要轉動旋鈕選擇洗衣程序。
4. 根據需要選擇程序功能。
5. 按「啟動/暫停」鍵，開始洗滌。
6. 結束程序時，將會發出提示音。

首次及日常使用

使用羊毛洗程序

- 開機後，轉動程序旋鈕以選擇「羊毛/手洗」。

注意

- 洗滌前請先確認衣物上的護理標籤指示。
- 程序完成後，請立即將衣物取出，並掛起風乾，以免放置時間過長而令衣物變形。
- 為防止衣物纖維受損，水溫設定不應超過40°C。
- 使用羊毛專用洗滌劑以達至最佳洗衣效果。
- 將白色或明亮色彩的衣物與深色衣物分開洗滌。

清潔和保養

- 請定期進行洗衣機的清潔和保養工作，良好的保養習慣會延長洗衣機的使用壽命。
- 執行任何清潔和保養之前，請拔掉電源插頭，防止危險發生。

清潔洗衣機的外部

- 每次使用完後，請用柔軟乾淨的軟布擦拭機身。當污漬嚴重時，可在布上加上適量的洗滌劑或肥皂水擦拭。
- 不可用水直接沖洗機身。
- 不可使用去污粉、稀釋劑、汽油、酒精等化學物品擦拭機身。

清潔洗衣機膠圈

每次使用完後，請用毛巾擦去污垢、紙屑等雜物。膠圈的溝槽內如有別針等細小物件，請務必將其取出。

清潔洗滌劑盒

輕輕抬起並將洗衣劑盒拉出（見圖），並取下分割器。用水沖洗所有部件，這個步驟應該經常重複，以確保潔淨。

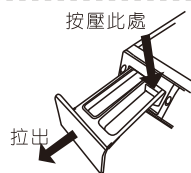

清潔和保養

- 請定期進行洗衣機的清潔和保養工作，良好的保養習慣會延長洗衣機的使用壽命。
- 執行任何清潔和保養之前，請拔掉電源插頭，防止危險發生。

清洗進水喉內的濾網（建議每半年一次）

1. 關閉水龍頭並取下洗衣機側進水軟管。
2. 取出進水閥口上的過濾網。
3. 用牙刷等工具將過濾網清洗乾淨後，再裝到進水閥口。
4. 將進水軟管重新連接上。



清潔滾筒（建議每運行約40次洗衣程序後一次）

洗衣機用過一段時間後，滾筒可能積聚污垢，此時可運行「清潔滾筒」程序保持滾筒潔淨。（注意：請勿放入衣物）

清潔濾網/排走積水（建議每月一次）

1. 先拔下電源插頭，然後用硬幣類物品插入水泵蓋上方的卡槽，打開水泵過濾器蓋。（注意：如果使用過熱洗程序，排走積水前應等待水冷卻下來）
 2. 逆時針轉動取出過濾器。
 3. 將過濾器用水沖洗乾淨。
 4. 將過濾網塞回原位，然後順時針擰緊，扣好水泵裝飾蓋。
- 注意：1. 過濾器必須旋緊以免導致漏水；
2. 機器運行時請勿進行過濾器清洗工作。

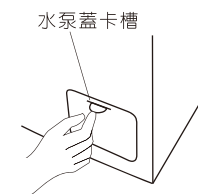

故障排除

異常問題	原因/解決辦法
機門無法打開	<ul style="list-style-type: none"> ● 水溫過高或出現電源故障。 ● 設置了兒童安全鎖功能。 ● 機門與膠圈之間有衣物被夾住。
洗衣機有異味	<ul style="list-style-type: none"> ● 運行「清潔滾筒」程序清洗本機，進行此程序時，必須將滾筒內所有衣物移走。
洗衣機不進水	<ul style="list-style-type: none"> ● 水龍頭是否已開啟。 ● 進水管或過濾網被堵塞。
洗滌中排水	<ul style="list-style-type: none"> ● 放入過多的洗衣劑。
程序時間於運行時改變	<ul style="list-style-type: none"> ● 顯示屏上的程序時間只供參考，實際程序時間會因不同的因素自動調整。
洗衣機運行時有噪音	<ul style="list-style-type: none"> ● 插頭沒有正確插在插座內。 ● 安裝完成後搬運螺柱未被正確移走。 ● 膠圈溝槽內有細小物件卡住。
停電後	<ul style="list-style-type: none"> ● 於恢復供電後，請重新開機以啟動/繼續程序。
手動打開機門	<ul style="list-style-type: none"> ● 如因長時間停電而想取出衣物時，拔下電源插頭，待滾筒停止轉動後，向下拉扯機身前蓋右下角的應急拉繩，聽到輕微響聲後，可以打開機門。 (打開機門前請先確認筒內水位低於筒口及水溫低於60℃。)

故障排除

故障代碼	原因	檢查要點	解決方法
無顯示	洗衣機無法運作	<ul style="list-style-type: none"> ● 電源插座是否有電？ ● 電源綫插頭是否已插好？ ● 是否停電？ ● 電源保險絲是否熔斷？ 	
E11	洗衣機不進水	<ul style="list-style-type: none"> ● 水龍頭是否已打開？ ● 進水管或濾網是否被堵塞？ ● 自來水是否有供應？ 	檢查處理後，按「啟動/暫停」鍵一次重新運轉洗衣機。
E12	洗衣機不排水	<ul style="list-style-type: none"> ● 排水管是否正確放置？ ● 排水口位置是否過高？ ● 排水管是否被堵塞？ 	檢查處理後，按「啟動/暫停」鍵一次重新運轉洗衣機。
H	機門無法打開	<ul style="list-style-type: none"> ● 是否使用了水溫過高的熱水？ 	待水溫降到安全範圍時，機門將自動解鎖。
U3	洗衣機不脫水	<ul style="list-style-type: none"> ● 洗衣機是否放置平穩？ ● 是否放入了單件大型衣物？ ● 毛毯是否被卷成團放入？ 	建議重新分配衣物，加2-3件衣服，檢查確認後，關上機門，按「啟動/暫停」鍵一次重新運轉洗衣機。
U4	機門未有關上		關閉機門，待「門鎖提示燈」亮起後，按「啟動/暫停」鍵一次重新運轉洗衣機。
其它			請關機後重新啟動洗衣機，如仍然未能解決請致電售後服務。

WARNING - This appliance must be earthed. **警告 - 本電器必須接連地線**



FOR WASHER PLUG 3 PIN (BS Standard Plug With 10 Amp Fuse) **對於附有10安培三腳插頭的洗衣機**

The wires are coloured in accordance with the following code:
電源線的電源是根據以下顏色表示：

Green/yellow: Earth	Light Blue: Neutral	Brown: Live
綠/黃：地線	藍：中性線	棕：火線

The wires in the appliance may not correspond with the coloured markings identifying the terminals in your plug, if it is the case, proceed as follows:

由於本電器電源線的顏色不一定與您的插頭終端上的顏色標誌相同，因此請按以下步驟執行操作：

- The wire which is coloured green and yellow must be connected to the terminal in the plug which is marked with the letter E or by the earth symbol  or coloured green or green and yellow.
綠黃色電源線應該連接至插頭上標明E、地線符號 、綠色或黃綠色的終端。
- The wire which is coloured light blue must be connected to the terminal which is marked with the letter N or coloured white.
藍色電源線應該連接至插頭上標明N或白色的終端。
- The wire which is coloured brown must be connected to the terminal which is marked with the letter L or coloured black.
棕色電源線應該連接至插頭上標明L或黑色的終端。

AFTER-SALES SERVICE **售後服務**

IF AFTER CHECKING ON TROUBLESHOOTING PART, MACHINE FAULT STILL OCCURS, GET IN TOUCH WITH THE NEAREST AFTER-SALES SERVICE.

請先參閱「故障排除」嘗試解決洗衣機的運作問題。若洗衣機仍舊無法正常運作，請致電售後服務中心。

To receive assistance, call the number shown on the warranty card or follow the instructions on the website:

請致電保用證上顯示的號碼，或按照以下網址上的指引聯絡我們：
<http://www.whirlpool.com.hk>

When contacting our After-Sales Service, always specify:

當聯絡我們的客戶售後服務中心，請說明：

- a brief description of the fault;
- 簡單故障說明；
- the type and exact model of the appliance;
- 洗衣機的類型及型號(請參閱機門內的銘牌)；
- the service number (number after the word Service on the rating plate);
- 服務碼(機門內「維修」字樣後的號碼)；
- your full address and contact.
- 您的完整地址及聯絡電話。

If any repairs are required, please contact an authorised After-Sales Service (to guarantee that original spare parts will be used and repairs carried out correctly).

對於任何維修，使用我們授權的售後服務中心，以確保適當的維修和使用原廠零配件。