

Whirlpool

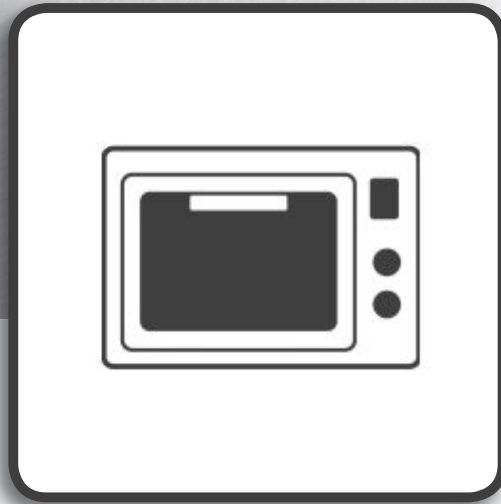

Health & Safety, Use & Care, Installation Guide and Online Warranty Registration Information

產品安全指引、使用說明、安裝指南及
網上登記保養資料

Model 產品型號 : MWP269TMS



www.whirlpool.com.hk
www.whirlpool.com.sg

目錄

■ 使用前的準備與須知

	頁
重要安全資訊	2
首次使用前須知	2
使用注意及建議事項	2-3
產品放置事項	3
接地說明	3
產品及配件結構圖	4-5
接水盤及水箱	6
控制面板	6
控制面板 – 基本功能說明	7
控制面板 – 主要功能介紹	8
控制面板 – 主要功能詳細說明	9-11
使用及烹調小貼士	12
烹調用具的選擇	13-14

■ 操作方法說明

	頁
設置時鐘	15
微波模式	16
蒸氣模式	17
蒸氣+微波模式	18
頂部燒烤模式	19
頂部燒烤+微波模式	20
底部燒烤模式	21
上下燒烤模式	22
上下燒烤+微波模式	23
熱風對流模式	24
加強熱風對流	25
加強熱風對流+微波模式	26
全功能蒸焗模式	27
全功能蒸焗+微波模式	28

	頁
保溫模式	29
乾果模式	30
慢煮模式	31
發酵模式	32
翻熱麵包模式	33
解凍模式	34
預熱模式	35-36
氣炸模式	37
烘乾爐腔模式	38
除垢模式	39-40
DIY煮食模式	41-42
烹調過程中調校 / 結束後追加時間功能	43-44
預約功能	45-46
自動菜單	47-49
餘溫高溫提示	50
童鎖功能	50

■ 清潔及保養

	頁
清潔及保養	51-53

■ 其他須知

	頁
故障排解	54-55
產品規格	56

使用前的準備與須知

■ 重要安全資訊

本說明包含有關產品安全、使用、維護及保養的重要資訊，請仔細閱讀本說明書，並將本說明書存放於容易提取的地方，以備將來查閱。

■ 首次使用前須知

1. 此產品很重，需要兩個人或以上安裝或移動此產品，必須將產品放置在堅固及平穩的表面，否則會造成身體傷害或產品損壞。
2. 此產品只設計作室內和家庭用途。請依照說明書內列明的煮食方法使用。切勿使用此產品作戶外、商業或其它用途。
3. 請確保家中使用的電壓與產品標籤上的電壓一致。
4. 產品送抵後請確保產品沒有損壞。如產品出現下列情況，請勿操作本產品：例如電源線或插頭受損、產品無法正常操作、產品受損或曾墜落。如果出現任何損壞，請聯絡惠而浦客戶服務部。
5. 切勿把電源線或插頭浸入水中，並避免電源線接觸高溫的表面，以免發生觸電，火災或其他意外。
6. 此座檯式微蒸烤焗爐只設計作座檯式使用，不可以作嵌入式安裝。
7. 產品的四周必須保留足夠的通風空間，切勿在爐頂放置任何物件並與頂部壁櫃距離至少 5 厘米；兩旁應與牆壁距離至少 1 厘米。
8. 請勿阻擋或堵塞微蒸烤焗爐的散熱通風口，以免對微蒸烤焗爐造成損壞。
9. 生產商不承擔一切由於客戶不正確使用本產品而產生的問題。
10. 機身頂部排氣出風口會有蒸氣排出，切勿遮蓋排氣出風口，以免損壞微蒸烤焗爐。
11. 應使用耐高溫容器進行烹調，如耐熱性玻璃、耐熱性塑料容器等。所有非耐熱性容器都不應放進微蒸烤焗爐使用。蒸煮容器耐熱溫度應高於120°C，而烤焗容器耐熱溫度應高於 250°C。
12. 第一次使用各種燒烤或烤焗的功能時，可能會產生氣味，這是正常現象。

■ 使用注意及建議事項

1. 如發現爐門或爐門密封邊損壞時，請停止使用產品並儘快聯絡惠而浦客戶服務部。
2. 如電源線何損壞，必須由供應商/製造商或合格技術人員更換，以免造成危險。
3. 請勿於此爐附近加熱或使用易燃物品，以免產生火警或爆炸。
4. 切勿使用本產品烘乾布料、紙張、香料、藥材、木材、花朵或其他易燃的物件，否則可能會造成火災。
5. 切勿過度烹調食物，否則可能引致火災。
6. 使用微蒸烤焗爐時切勿離開，尤其正當在使用紙、塑膠或其他易燃材料的物件進行烹調。當用作為食物加熱時，紙張可能會著火或燒焦，某些塑料則可能溶化。如發現有物件在蒸焗爐內或外被點燃或冒煙，請將爐門關上並關掉微蒸烤焗爐。同時拔掉電源線並將裝設有漏電斷路器的插座電源切斷。
7. 切勿在爐內使用腐蝕性化學品或氣體。此微蒸烤焗爐專為加熱食物或烹煮食物而設計，並不適合工業或實驗用途。
8. 此產品並非設計給身體，感官或精神上能力不足，或經驗及知識不足的人士使用(包括兒童)，除非監護其安全的負責人監督或指引其使用。
9. 每次完成烹調並待微蒸烤焗爐冷卻後，請抹走可能凝固於爐腔內的殘留物。爐腔頂部最容易出現燒焦情況，應將爐腔頂部擦洗乾淨。為確保食物得到最佳烹調效果，於每次使用後，請保持爐腔完全乾透。
10. 從微蒸烤焗爐內提取食物及器皿時，應使用隔熱手套，以免燙傷。
11. 當微蒸烤焗爐運作時，請避免接觸爐腔內的發熱管，以免造成危險。
12. 切勿將爐腔作存放物件之用。
13. 奶樽或嬰兒食物器皿中的食物或飲料加熱後，請務必在餵食前將食物或飲料加以攪拌，並檢查食物的溫度，確保熱力分佈均勻，以避免燙傷或灼傷嬰兒。
14. 當完成蒸或烤焗煮食模式後，應等待 10-15 分鐘才進行其他烹調模式。
15. 剛完成烤焗煮食後或爐腔處於高溫狀態下，使用蒸氣相關模式，爐腔內的蒸氣可能會迅速蒸發，蒸氣不易被看到。這是正常現象。
16. 當使用微蒸烤焗爐時，切勿用手觸摸爐門、爐窗及外框。

使用前的準備與須知

17. 請使用直接從水喉取的自來水、食用水或蒸餾水注入儲水箱，直至水位達到標註“MAX”（最高水位）的位置。
18. 水箱出現裂紋或缺口時，請勿繼續使用，以免引起因漏水而導致的漏電或觸電。
19. 為確保衛生，並防止冷凝水在微蒸烤焗爐內積聚，請於每次使用後清空水箱及確保爐腔完全乾透。
20. 除清水外，切勿使用儲水箱盛載其他液體（除垢劑除外）。
21. 以蒸氣模式烹調過程中儘量不要打開爐門，以免蒸氣流失和爐腔溫度下降，影響烹調效果。如有需要打開爐門，請酌量增加蒸煮時間。
22. 烹調過程中如需翻轉食物或因其它需要必須打開爐門時，請盡量不要靠近爐門（特別是臉部），以免燙傷。
23. 維修操作必須由專業人員進行。除專業人員外，任何維修操作均可能帶來危險。請勿擅自對產品進行拆卸、修理或改造。
24. 產品操作時，可接觸部份的溫度可能較高，切勿讓兒童靠近。
25. 通電後，切勿以濕手或其他身體部份接觸本產品、產品之電源線或插頭，以免發生危險。
26. 切勿放置或懸掛任何物件於爐門或門上的把手，以免影響門的開關及損壞門鉸。
27. 烹調結束後，電動風扇會繼續工作一段時間，以冷卻爐腔和電子零件，屬於正常現象。
28. 如未能妥善清潔產品及其配件，會導致器具表面劣化，這會影響器具的壽命，可能會導致危險的情況。
29. 清潔前請切斷電源，不可使用具有腐蝕性的清潔劑，以免損壞或腐蝕本產品。
30. 在除垢模式時，水箱的水會被加熱，並流到接水盤內，請勿讓兒童接觸或走近。
31. 請定期清除電源插頭上的灰塵。長期不使用時，請拔出電源插頭。拔除電源插頭時不要拉扯電線，應手握插頭拔除。
32. 請不要讓微蒸烤焗爐處於無人監看的狀態下工作。

33. 過熱的脂肪和油很容易著火。除了烤肉，在烹調過程中對油進行加熱也是很危險的，應禁止這樣操作。
34. 爐門負重不可超過 7 公斤，為避免損害微蒸烤焗爐，請勿把食物或任何重物放在爐門上。

■ 產品放置事項

1. 產品的四周必須有足夠的通風空間，切勿在爐頂放置任何物件並與頂部壁櫃距離至少 30 厘米；兩旁應與牆壁距離至少 5 厘米；機背可貼近牆。

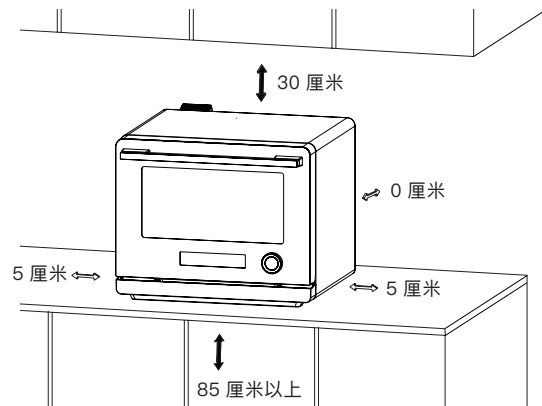

2. 請勿堵塞出風口，入氣口，否則可能造成火災。請經常保養，避免垃圾、灰塵等堵塞出風口，入氣口。
3. 不可將產品放置於高溫潮濕地方。例如煤氣爐，帶電區或水槽旁邊等。
4. 產品必須平放在堅固及平穩的表面。

■ 接地說明

本產品必須接地使用。萬一漏電，接地可以提供電流回路以避免觸電。本產品提供的接地插頭必須插在單相兩極帶接地的插座上。

使用前的準備與須知

■ 產品及配件結構圖

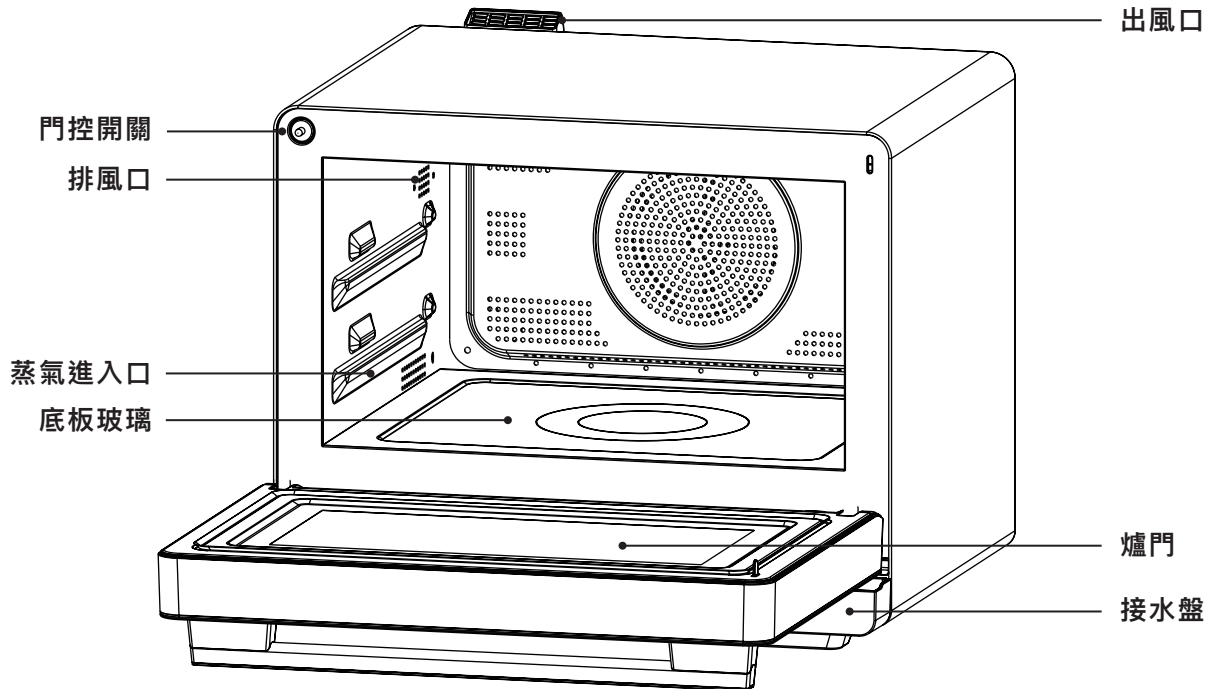

- 出風口：排出爐內多餘的熱氣及水蒸氣。
- 排風口：爐腔內多餘的蒸氣及熱氣由此孔抽到出風口。
- 蒸氣進入口：讓蒸氣進入爐腔內。
- 爐門：1. 確保爐門關上後，才開啟烹調程式。
2. 在烹調過程中，將爐門打開，烹調會暫停；把爐門關上後，會自動繼續原先的烹調設定。
- 接水盤：盛載開門後流出的倒汗水
- 門控開關：感應爐門是否關上。
- 底板玻璃：當使用微波功能烹調時，將盛載食物的容器放在底板玻璃上

使用前的準備與須知

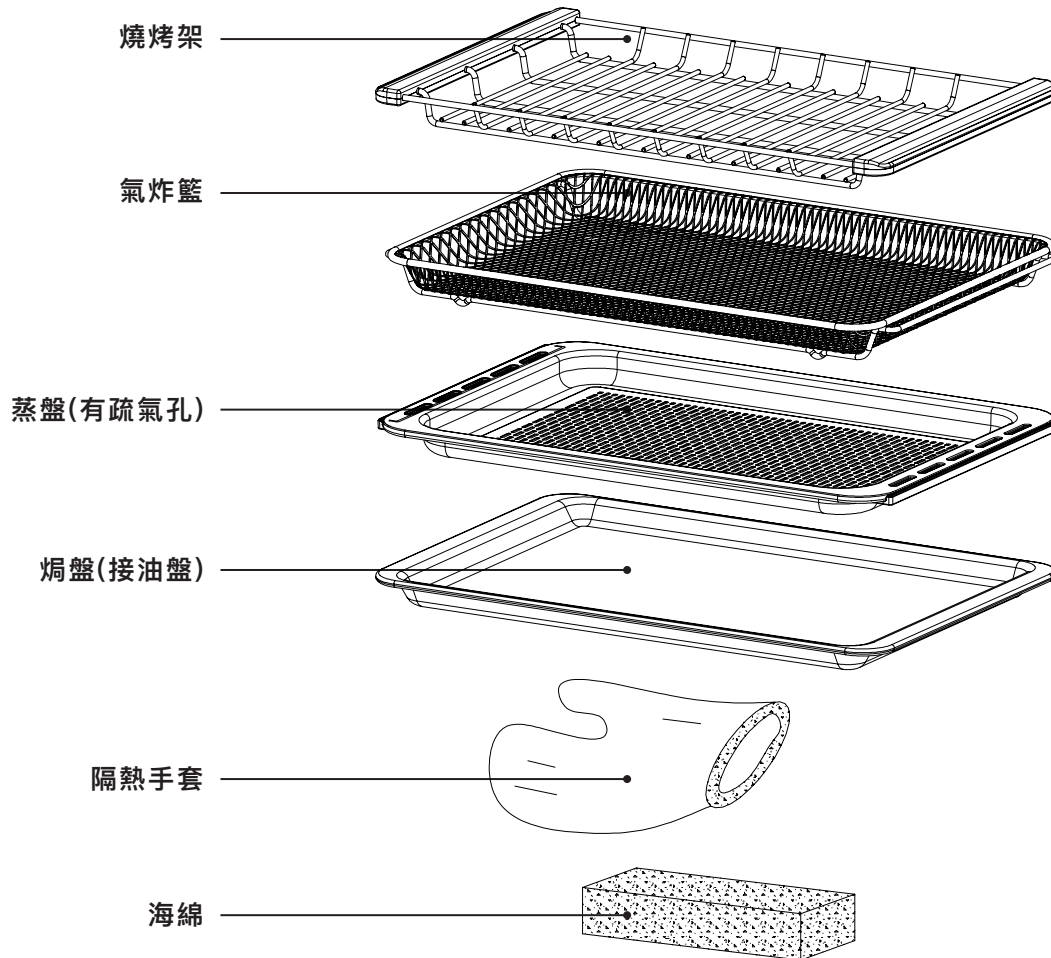

1. 燒烤架

主要用於所有使用發熱管加熱的模式，如各個「燒烤」或「熱風對流」或「熱風」等模式使用。

2. 氣炸籃

供氣炸模式時使用，切勿用於帶有微波的煮食功能。

3. 焗盤 (接油盤)

主要用於「熱風加蒸氣」、「全功能蒸焗」或「熱風」等模式時使用。或於烹調肉類時放於底層，盛載煮食中滴下來的油。

4. 隔熱手套

由蒸焗爐拿出食物或托盤時使用。

5. 海綿

用於吸取爐腔內的倒汗水。

使用前的準備與須知

■ 接水盤及水箱

水箱：盛載清水以產生蒸氣。



接水盤：盛載開門後流出的倒汗水。

安裝方法：
取出方法/裝入方法

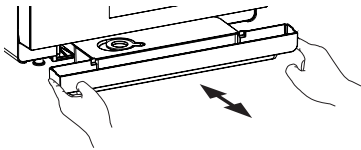

取出時可能有用剩的水，請小心；
裝入時請確保水箱蓋緊密關閉，將水箱推至最入，
確保水箱安裝到位；傾斜可能會使水溢出，請時刻
保持水平狀態

裝水的方法

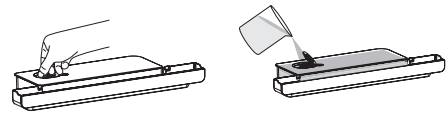

使用蒸氣烹調前，請打開圓形矽膠蓋，
注入純水或蒸餾水，直到裝滿水箱為止。

注意!

- 首次使用或長時間沒使用蒸氣模式煮食時，請先使用蒸氣模式進行清潔；
- 請不時清潔水箱及接水盤；
- 請盡量使用純水或蒸餾水煮食，否則可能有水垢產生；
- 進行蒸氣煮食時，請務必將水箱加滿水，確保水箱安裝妥當，水太少或安裝不到位，進行蒸氣煮食時會出現「請加水」提示，並暫停煮食。

■ 控制面板

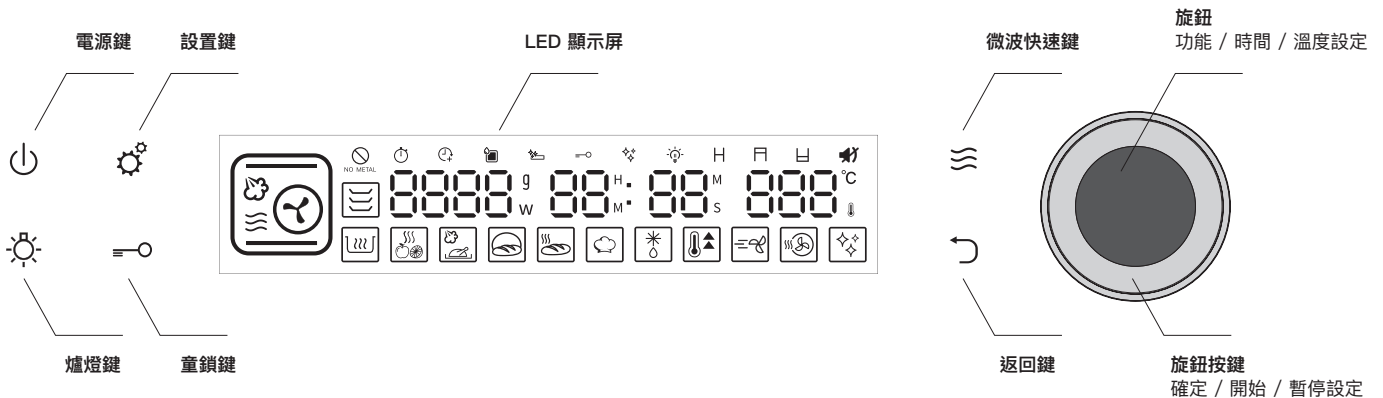

使用前的準備與須知

■ 控制面板 – 基本功能說明

圖示	功能說明
	旋鈕 功能 / 時間 / 溫度設定 旋鈕按鍵 確定 / 開始 / 暫停設定
	設定鍵/自動菜單鍵 1. 待機狀態下，輕按一次進入自動菜單功能設定； 2. 待機狀態下，長按3 秒進入時鐘設定； 3. DIY功能設定狀態下，按此鍵進入下一段功能設定； 4. 煮食時間/溫度設定狀態下，長按此鍵進入預約設定； 5. 煮食過程中，長按此鍵查看爐腔內的實際溫度。 6. 暫停煮食狀態下，按此鍵重新調整煮食時間/溫度；
	返回鍵 1. 返回 / 取消； 2. 在設置過程中，按返回鍵可回到上一個畫面，即可重新調整烹調模式或烹調時間。 3. 靜音模式 啟動靜音模式：在待機狀態下長按返回鍵 3 秒即啟動靜音模式，顯示屏上靜音圖示亮起，按鍵音效提示關閉。 解除靜音模式：在待機狀態下長按返回鍵 3 秒即可解除靜音模式。
	爐燈鍵 1. 輕按一次，爐燈亮 3 分鐘，顯示屏上不會顯示爐燈圖標； 2. 烹調期間，長按 3 秒，爐燈長亮，顯示屏上會顯示爐燈圖標，再長按 3 秒取消長亮； 3. 待機狀態下，長按 3 秒，爐燈長亮5分鐘，顯示屏上會顯示爐燈圖標，如5分鐘內沒有任何操作，微蒸烤焗爐會進入待機模式，爐燈自動關掉。 4. 打開爐門，爐燈亮 3 分鐘。
	童鎖鍵 長按 3 秒可啟動 / 解除童鎖。 啟動童鎖：長按童鎖鍵 3 秒啟動，控制面板會被鎖定並不能操作。 解除童鎖：長按童鎖鍵 3 秒即可解除童鎖功能。
	電源鍵 如果開啟微蒸烤焗爐後，沒有進行任何操作，包括打開或關閉爐門，5 分鐘後，微蒸烤焗爐將自動進入省電模式，顯示屏會熄滅。省電模式下只有電源鍵能操作。
	微波快速鍵 1. 待機狀態下或在其他功能設定狀態下，按此鍵進入微波功能設定。 2. 長按3 秒啟動“Jet Start”功能：微波在最高功率（最大火力）下煮食30秒

使用前的準備與須知

■ 控制面板 – 主要功能介紹

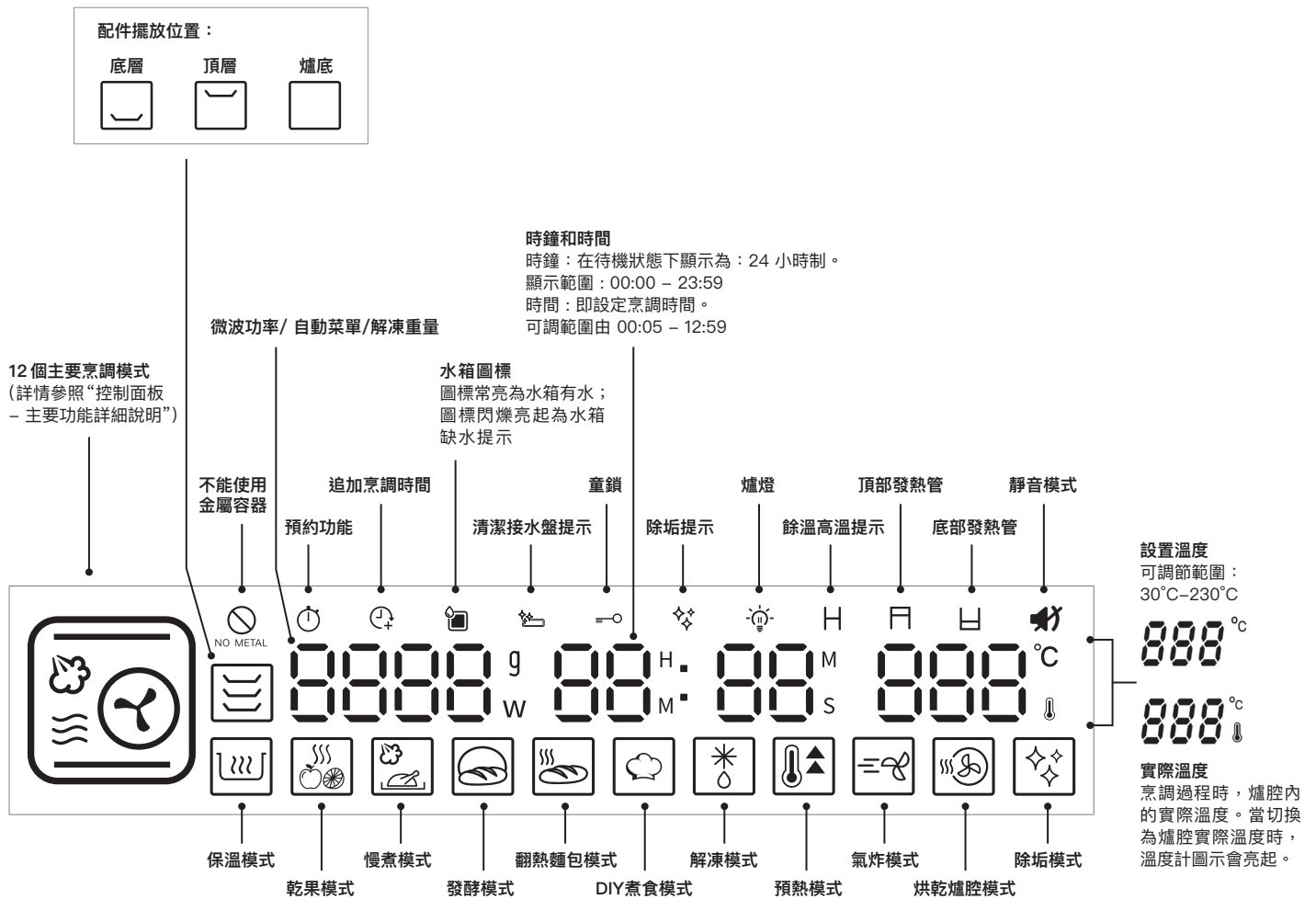



使用前的準備與須知

■ 控制面板 – 主要功能詳細說明

主要烹調模式



圖示	模式	功能介紹	默認時間 / 溫度	時間 / 溫度選擇範圍
	蒸氣	此模式以蒸氣烹調食物，可保留食物原有的味道，營養及顏色。適合蒸煮蔬菜，肉類，海鮮或燉湯等。	20 分鐘 / 100°C	時間 5–419 分鐘 (最長6小時59分鐘) 溫度 50 – 110°C
	蒸氣+微波	此模式以蒸氣加上微波以較短時間烹調食物，可保留食物原有的味道，營養及顏色。適合蒸煮需要長時間烹調的食物如燉牛腩或燉湯等。	15 分鐘 / 100°C	時間 5–419 分鐘 (最長6小時59分鐘) 溫度 50 – 110°C
	頂部燒烤	適合燒烤食材，或用於烤焗的最後階段，作加強食物金黃度及烤色的作用。	25 分鐘 / 110°C	時間 5–239 分鐘 (最長3小時59分鐘) 溫度 50 – 230°C
	頂部燒烤+微波	適合燒烤食材，頂部發熱管加上微波以較短時間烹調食物。	20 分鐘 / 100°C	時間 5–239 分鐘 (最長3小時59分鐘) 溫度 50 – 230°C
	底部燒烤	適合烘焙的最後階段或局部時段只需底部加熱的食物，如薄餅或馬卡龍等菜式。熱力會從底部散發出來。	20 分鐘 / 100°C	時間 5–239 分鐘 (最長3小時59分鐘) 溫度 50 – 230°C
	上下燒烤	傳統的一層烘焙與烤焗。熱力會從上面及底部散發出來，使食物達到均勻的烤焗效果。適用於烹調肉類、魚類、麵包以及各式曲奇、糕點及甜品等。尤其適合頂部有濕潤配料的蛋糕。	30 分鐘 / 180°C	時間 5–239 分鐘 (最長3小時59分鐘) 溫度 50 – 230°C
	上下燒烤+微波	頂及底部發熱管加上微波，以較短時間烹調食物使食物達到均勻的烤焗效果。適用於烹調肉類、魚類、麵包以及各式曲奇、糕點及甜品等。	25 分鐘 / 180°C	時間 5–239 分鐘 (最長3小時59分鐘) 溫度 50 – 230°C
	熱風對流	上下發熱線及背部風扇同時運作，用於各種烤焗菜式，如肉類、海鮮類、薄餅、麵包以及各式曲奇、糕點及甜品等。	20 分鐘 / 160°C	時間 5–239 分鐘 (最長3小時59分鐘) 溫度 80 – 230°C
	加強熱風對流	以較短時間烤焗食物，加快烹調時間。適用烤焗體積較大的肉類及糕點。	25 分鐘 / 180°C	時間 5–239 分鐘 (最長3小時59分鐘) 溫度 80 – 230°C
	加強熱風對流+微波	於加強熱風對流的操作上加上微波以更短時間烤焗食物，減少烹調時間。適用烤焗體積較大的肉類及糕點。	15 分鐘 / 120°C	時間 5–239 分鐘 (最長3小時59分鐘) 溫度 50 – 230°C

使用前的準備與須知

圖示	模式	功能介紹	默認時間 / 溫度	時間 / 溫度選擇範圍
	全功能蒸焗	此模式集合上下火、熱風、蒸氣功能於一身，全功能的完美結合。煮食過程中加入蒸氣，讓烹調的食物不會因烤焗而流失水份。適用於煮各種食物。例如較大的肉類或烤焗濕潤的蛋糕。	20 分鐘 / 180°C	時間 5-239 分鐘 (最長3小時59分鐘) 溫度 80 - 230°C
	全功能蒸焗 +微波	此模式集合上下火、熱風、蒸氣、微波功能於一身，全功能的完美結合，加入微波更有助減少烹調時間。	15 分鐘 / 180°C	時間 5-239 分鐘 (最長3小時59分鐘) 溫度 80 - 230°C
	微波	微波能迅速加熱食物，適合用於加熱食物。	30 秒 / 900W	10秒 - 90分55秒 100W - 900W

使用前的準備與須知

烹調功能

圖示	模式	功能介紹	默認時間 / 溫度	時間 / 溫度選擇範圍
	保溫	以熱風保溫食物。適合把剛煮的食物保溫。	20 分鐘 / 55°C	時間 5–419 分鐘 (最長6小時59分鐘) 溫度 50 – 110°C
	乾果	以低溫熱風去風乾食物，適合製作各種生果片，蔬菜片或肉乾。	20 分鐘 / 60°C	時間 5–779 分鐘 (最長12小時59分鐘) 溫度 40 – 90°C
	慢煮	以蒸氣維持爐腔的溫度。以低溫慢煮，沒有經過高溫加熱，可使各種肉類和海鮮保存原有的鮮味。需配合真空袋使用。	60 分鐘 / 60°C	時間 60 – 779 分鐘 (最長12小時59分鐘) 溫度 50 – 90°C
	發酵	此模式以蒸氣運作，使爐腔達至調校的穩定而潮濕的環境。用於麵團發酵，例如薄餅的餅底或製作麵包時的麵團。麵團發酵的速度會比在室溫下快，麵團表面也不會過乾。	40 分鐘 / 35°C	時間 5 – 779 分鐘 (最長12小時59分鐘) 溫度 25 – 50°C
	翻熱麵包	此程式會以已調節的最佳溫度去翻熱麵包，過程中加入蒸氣，使效果像剛出爐的新鮮麵包。備有兩種翻熱麵包模式：室溫和冷藏麵包。	10 分鐘 / 180°C	時間 5–59 分鐘 溫度不可調校
	解凍	用於解凍冷藏或冷凍食物。	7分鐘40秒 / 500g	100g – 2000g
	預熱 – 蒸氣	以蒸氣進行預熱。使爐腔達到預設溫度。	當前時間 / 100°C	溫度 50 – 110°C
	預熱 – 烤焗	以烤焗進行預熱。使爐腔達到預設溫度。	當前時間 / 180°C	溫度 100– 230°C
	氣炸	以風扇將熱力在爐腔內運行產生對流以較短時間烤焗食物造出香脆效果。適用於需要氣炸的食物或烤焗體積較大的肉類及糕點。	25 分鐘 / 180°C	時間5–239分鐘 (最長3小時59分鐘) 溫度80 – 230°C
	烘乾爐腔	此模式會以高溫加熱爐腔，蒸發爐腔中多餘的水份和蒸氣。此功能適用於任何蒸氣烹調的模式後使用。	15 分鐘 / 180°C	時間不可調校 溫度不可調校
	除垢	當蒸氣模式或其他帶有蒸氣功能模式使用的累計時間達到 100 個小時，“除垢提示”圖示會亮起，提醒用戶進行除垢模式。需配合除垢劑使用。	60 分鐘	時間不可調校 溫度不可調校
	DIY煮食	一次性自動完成多達三種不同煮食模式。		

使用前的準備與須知

■ 使用及烹調小貼士



1. 所有烹調模式的最短設定的時間為 5 分鐘。(除追加烹調時間功能外)
2. 完成烹調後，風扇會延時工作 3 分鐘，將爐腔內的熱量排出，這是正常現象。
3. 烹調過程中，如果將爐門打開，微蒸烤焗爐會自動暫停；將爐門關上，則自動啟動並按餘下設定時間及溫度繼續烹調。
4. 加熱湯類、汁類或飲品等液體食物時，取出時必須小心。在烹調時，請留意以下各點：
 - (a) 不要過度加熱。否則在取出食物時，會由於突然沸騰導致液體飛濺而燙傷。
 - (b) 液體食物加熱時，液體不要多於容器的八成滿。因為加熱少量液體食物會由於沸騰而導致液體突然飛濺。
 - (c) 加熱前或加熱途中請攪拌。
 - (d) 加熱後，先讓食物在爐內放置片刻，略加攪拌後取出。
 - (e) 使用奶瓶或加熱嬰兒食物後，即攪拌或搖動，餵食前應檢查溫度，避免燙傷。
5. 如要在烹調過程中，檢查食物溫度，必須使用焗爐專用的溫度計檢查。如果食物烹調時間不足則再放入爐內繼續烹調。
6. 烤焗完成後，建議立刻取出以免殘留熱量使食物過熱或使烤色變深。
7. 烤焗過程中為維持爐內溫度，請儘量避免開關爐門檢查食物，以免影響爐內溫度。如於煮食過程中曾打開爐門，請相應地增加烹食時間。
8. 如果擔心烤色不均勻，請在加熱途中調整或翻轉食物、蒸焗盤的位置或方向。

使用前的準備與須知

■ 烹調用具的選擇

容器類別	微波	微蒸烤組合	蒸氣	燒烤/熱風對流
耐熱性玻璃容器 	✓	✓	✓	✓
不耐熱性玻璃容器 	✗	✗	✗	✗
耐熱性塑膠容器 	✓	✓	✓	✗
不耐熱性塑膠容器 	✗	✗	✗	✗
陶瓷・瓷器 	✓	✓	✓	✓
漆器 	✗	✗	✗	✗

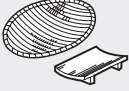
使用前的準備與須知

容器類別	微波	微蒸烤組合	蒸氣	燒烤/熱風對流
鋁等的金屬容器 	X	X	✓	✓ 註：如便金屬容器的手柄是以樹脂物料製造，便不能使用。
木·竹·紙制容器 	X 容易引起燃燒	X 容易引起燃燒	X 註：木、竹製容器及經過耐熱加工處理的紙製品可使用。	X 註：烹調溫度在230°C或以下，可以使用經過耐熱加工處理的紙製容器。
微波專用保鮮膜 	✓ 建議使用耐熱溫度為140 °C 的保鮮膜。 註：不能烹調多油的食物不能使用。	X	X	X 保鮮膜遇到高溫會熔化。
鋁箔 (即家用錫紙) 	X	X	✓	✓

使用微波爐功能時，可以使用適合微波適用之容器直接放在爐腔底部(微晶玻璃)上進行煮食。

※ 禁止使用金屬器皿，否則可能會產生火花，導致故障

※ 食物直接放在爐腔中央，如食物多於一碟可以參考以下擺放方法（食物集中在中央）

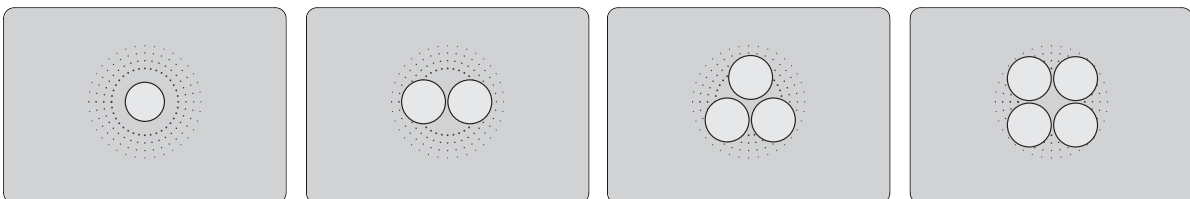

操作方法說明

■ 設置時鐘

首次開機後，微蒸烤焗爐發出「必」一聲後即進入待機畫面，時鐘默認顯示 12:00（如下圖），顯示屏全亮。



在開機後畫面後，若在 5 分鐘內沒有進行任何操作，會自動進入省電模式，此時顯示屏熄滅，省電模式下只有電源鍵能操作。省電模式下按“電源鍵”退出省電模式，機器進入開機後畫面。

例如：設置現前時間為 13 時 20 分。

操作步驟：

1. 在待機畫面下，長按設置鍵  3 秒，小時位閃爍（如下圖）；



2. 轉動旋鈕直到顯示小時位轉至 13，按旋鈕確認。（如下圖）然後畫面會自動跳至分鐘選項。



3. 轉動旋鈕直到顯示分鐘轉至 20，按旋鈕確認。（如下圖）



4. 完成時間設置。（如下圖）



注意：在設置過程中，若連續 5 分鐘內用戶沒有任何操作，當前所有設置將會被取消並返回到待機畫面，進入待機狀態。

操作方法說明

■ 微波模式

建議使用之配件：

配件擺放位置：

微波能迅速加熱食物，適合用於加熱食物。

	微波功率	時間
開機預設	900W	30秒
設定範圍	100W – 900W	10秒 – 90分鐘55秒

 **注意!** 切勿在此煮食模式下使用金屬容器煮食 (建議使用之配件除外)，否則會產生火花，導致故障。
NO METAL

例如：設置烹調時間為 2 分鐘，微波功率為900W。

1. 待機狀態下，按  進入微波功能設定。微波功率閃爍，逆時針旋轉旋鈕至 900W按旋鈕確認。(如下圖) 然後畫面會自動跳至分鐘選項。



2. 轉動旋鈕直到顯示分鐘位轉至02，按旋鈕確認。(如下圖) 然後畫面會自動跳至秒選項。



3. 顯示秒位於00閃爍，按旋鈕確認。(如下圖)



4. 設置完成，開始烹調。

操作方法說明

■ 蒸氣模式

建議使用之配件：

配件擺放位置：

此模式以蒸氣烹調食物，可保留食物原有的味道，營養及顏色。適合蒸煮蔬菜，肉類，海鮮或燉湯等。每次使用前，請確保水箱已加滿水。

	溫度	時間
開機預設	100°C	20分鐘
設定範圍	50°C – 110°C	5 分鐘 – 6 小時 59 分鐘

例如：設置烹調時間為 1 小時 40 分鐘，溫度為 110°C。

操作步驟：

1. 在待機狀態下，順時針旋轉旋鈕至  蒸氣模式圖示閃爍，按旋鈕確認功能。(如下圖) 然後畫面會自動跳至小時選項。



2. 轉動旋鈕直到顯示小時位轉至 01，按旋鈕確認。(如下圖) 然後畫面會自動跳至分鐘選項。



3. 轉動旋鈕直到顯示分鐘轉至 40，按旋鈕確認。(如下圖) 然後畫面會自動跳至溫度選項。



4. 轉動旋鈕直到顯示溫度轉至 110°C，按旋鈕確認。(如下圖)



5. 設置完成，開始烹調。

操作方法說明

■ 蒸氣+微波模式

燒烤架

建議使用之配件：



底層

配件擺放位置：



此模式以蒸氣加上微波以較短時間烹調食物，可保留食物原有的味道，營養及顏色。適合蒸煮需要長時間烹調的食物如焗牛腩或燉湯等。

	溫度	時間
開機預設	100°C	15分鐘
設定範圍	50°C – 110°C	5 分鐘 – 6 小時 59 分鐘



注意! 切勿在此煮食模式下使用金屬容器煮食 (建議使用之配件除外)，否則會產生火花，導致故障。

例如：設置烹調時間為 1 小時 40 分鐘，溫度為 90°C。

操作步驟：

1. 在待機狀態下，順時針旋轉旋鈕至  蒸氣 + 微波模式圖示閃爍，按旋鈕確認功能。(如下圖) 然後畫面會自動跳至小時選項。



2. 轉動旋鈕直到顯示小時位轉至 01，按旋鈕確認。(如下圖) 然後畫面會自動跳至分鐘選項。



3. 轉動旋鈕直到顯示分鐘轉至 40，按旋鈕確認。(如下圖) 然後畫面會自動跳至溫度選項。



4. 轉動旋鈕直到顯示溫度轉至 90°C，按旋鈕確認。(如下圖)



5. 設置完成，開始烹調。

操作方法說明

■ 頂部燒烤模式

建議使用之配件：

燒烤架

配件擺放位置：

底層

適合燒烤食材，或用於烤焗的最後階段，作加強食物金黃度及烤色的作用。

	溫度	時間
開機預設	110°C	25分鐘
設定範圍	50°C – 230°C	5 分鐘 – 3 小時 59 分鐘

例如：設置烹調時間為 40 分鐘，溫度為 210°C。

操作步驟：

1. 在待機狀態下，順時針旋轉旋鈕至  頂部燒烤模式圖示閃爍，按旋鈕確認功能。(如下圖) 然後畫面會自動跳至小時選項。



2. 按順時針旋轉旋鈕確認小時位 00 設定。(如下圖) 然後畫面會自動跳至分鐘選項。

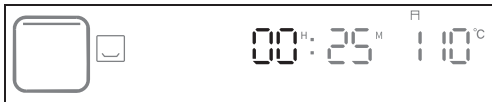

3. 按順時針旋轉旋鈕直到顯示分鐘轉至 40，按旋鈕確認。(如下圖) 然後畫面會自動跳至溫度選項。



4. 按順時針旋轉旋鈕直到頂部發熱管顯示溫度轉至 210°C，按旋鈕確認。(如下圖)



5. 設置完成，開始烹調。

操作方法說明

■ 頂部燒烤+微波模式



燒烤架

建議使用之配件：



底層

配件擺放位置：



適合燒烤食材，頂部發熱管加上微波以較短時間烹調食物。

	溫度	時間
開機預設	100°C	20 分鐘
設定範圍	50°C – 230°C	5 分鐘 – 3 小時 59 分鐘

 注意! 切勿在此煮食模式下使用金屬容器煮食 (建議使用之配件除外)，否則會產生火花，導致故障。
NO METAL

例如：設置烹調時間為 40 分鐘，溫度為 210°C。

操作步驟：

1. 在待機狀態下，順時針旋轉旋鈕至  頂部燒烤+微波模式圖示閃爍，按旋鈕確認功能。(如下圖)然後畫面會自動跳至小時選項。



2. 按順時針旋轉旋鈕確認小時位 00 設定。(如下圖) 然後畫面會自動跳至分鐘選項。

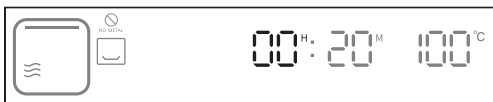

3. 按順時針旋轉旋鈕直到顯示分鐘轉至 40，按旋鈕確認。(如下圖) 然後畫面會自動跳至溫度選項。



4. 按順時針旋轉旋鈕直到頂部發熱管顯示溫度轉至 210°C，按旋鈕確認。(如下圖)



5. 設置完成，開始烹調。

操作方法說明

■ 底部燒烤模式

建議使用之配件：

燒烤架

配件擺放位置：

底層

適合烘焙的最後階段或局部時段只需底部加熱的食物，如薄餅或馬卡龍等菜式。熱力會從底部散發出來。

	溫度	時間
開機預設	100°C	20分鐘
設定範圍	50°C – 230°C	5分鐘 – 3小時 59分鐘

例如：設置烹調時間為 40 分鐘，溫度為 210°C。

操作步驟：

1. 在待機狀態下，順時針旋轉旋鈕至  底部燒烤模式圖示閃爍，按旋鈕確認功能。(如下圖) 然後畫面會自動跳至小時選項。



2. 按順時針旋轉旋鈕確認小時位 00 設定。(如下圖) 然後畫面會自動跳至分鐘選項。



3. 按順時針旋轉旋鈕直到顯示分鐘轉至 40，按旋鈕確認。(如下圖) 然後畫面會自動跳至溫度選項。



4. 按順時針旋轉旋鈕直到頂部發熱管顯示溫度轉至 210°C，按旋鈕確認。(如下圖)



5. 設置完成，開始烹調。

操作方法說明

■ 上下燒烤模式

建議使用之配件：

燒烤架

配件擺放位置：

底層

	溫度	時間
開機預設	180°C	30 分鐘
設定範圍	50°C – 230°C	5 分鐘 – 3 小時 59 分鐘

例如：設置烹調時間為 40 分鐘，頂部發熱管溫度為 210°C，底部發熱管溫度為 180°C。

操作步驟：

1. 在待機狀態下，順時針旋轉旋鈕至  上下燒烤模式圖示閃爍，按旋鈕確認功能。(如下圖) 然後畫面會自動跳至小時選項。



2. 按順時針旋轉旋鈕確認小時位 00 設定。(如下圖) 然後畫面會自動跳至分鐘選項。



3. 按順時針旋轉旋鈕直到顯示分鐘轉至 40，按旋鈕確認。(如下圖) 然後畫面會自動跳至溫度選項。



4. 按順時針旋轉旋鈕直到頂部發熱管顯示溫度轉至 210°C，按旋鈕確認。(如下圖)



5. 按順時針旋轉旋鈕直到底部發熱管顯示溫度轉至 180°C，按旋鈕確認。(如下圖)



6. 設置完成，開始烹調。

操作方法說明

■ 上下燒烤+微波模式

建議使用之配件：

配件擺放位置：

頂及底部發熱管加上微波，以較短時間烹調食物使食物達到均勻的烤焗效果。適用於烹調肉類、魚類、麵包以及各式曲奇、糕點及甜品等。

	溫度	時間
開機預設	180°C	25分鐘
設定範圍	50°C – 230°C	5分鐘 – 3小時 59分鐘

 注意! 切勿在此煮食模式下使用金屬容器煮食 (建議使用之配件除外)，否則會產生火花，導致故障。
NO METAL

例如:設置烹調時間為 40 分鐘，頂部發熱管溫度為180°C，底部發熱管溫度為160°C。

操作步驟：

1. 在待機狀態下，順時針旋轉旋鈕至  上下燒烤+微波模式圖示閃爍，按旋鈕確認功能。(如下圖) 然後畫面會自動跳至小時選項。



2. 按順時針旋轉旋鈕確認小時位 00 設定。(如下圖) 然後畫面會自動跳至分鐘選項。

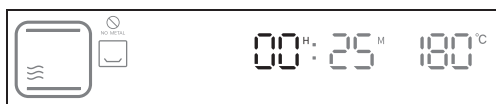

3. 按順時針旋轉旋鈕直到顯示分鐘轉至 40，按旋鈕確認。(如下圖) 然後畫面會自動跳至溫度選項。



4. 調校發熱管溫度，轉動旋鈕直到顯示溫度轉至 180°C，按旋鈕確認。



5. 設置完成，開始烹調。

操作方法說明

■ 熱風對流模式

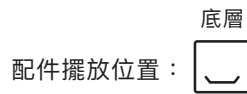
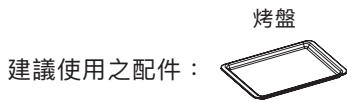

上下發熱線及背部風扇同時運作，用於各種烤焗菜式，如肉類、海鮮類、薄餅、麵包以及各式曲奇、糕點及甜品等。可把食物放在鋪有錫紙或牛油紙的燒烤架或焗盤上直接烤焗。

	溫度	時間
開機預設	160°C	20 分鐘
設定範圍	80°C – 230°C	5 分鐘 – 3 小時 59 分鐘

例如：設置烹調時間為 40 分鐘，頂部發熱管溫度為210°C，底部發熱管溫度為160°C。

操作步驟：

1. 在待機狀態下，順時針旋轉旋鈕至  熱風對流模式圖示閃爍，按旋鈕確認功能。(如下圖) 然後畫面會自動跳至小時選項。



2. 按旋鈕確認小時位 00 設定。(如下圖) 然後畫面會自動跳至分鐘選項。



3. 轉動旋鈕直到顯示分鐘轉至 40，按旋鈕確認。(如下圖) 然後畫面會自動跳至溫度選項。



4. 調校頂部發熱管溫度，轉動旋鈕直到顯示溫度轉至 210°C，按旋鈕確認。



5. 調校底部發熱管溫度，轉動旋鈕直到顯示溫度轉至 160°C。



6. 設置完成，開始烹調。

操作方法說明

■ 加強熱風對流模式

建議使用之配件：

配件擺放位置：

以較短時間烤焗食物，加快烹調時間。適用烤焗體積較大的肉類及糕點。建議把食物放在鋪有錫紙或牛油紙的焗盤上直接烤焗。

	溫度	時間
開機預設	180°C	25 分鐘
設定範圍	80°C – 230°C	5 分鐘 – 3 小時 59 分鐘

例如：設置烹調時間為 40 分鐘，溫度為 210°C。操作步驟：

1. 在待機狀態下，順時針旋轉旋鈕至  加強熱風對流模式圖示閃爍，按旋鈕確認功能。(如下圖) 然後畫面會自動跳至小時選項。



2. 按旋鈕確認小時位 00 設定。(如下圖) 然後畫面會自動跳至分鐘選項。



3. 轉動旋鈕直到顯示分鐘轉至 40，按旋鈕確認。(如下圖) 然後畫面會自動跳至溫度選項。



4. 轉動旋鈕直到顯示溫度轉至 210°C，按旋鈕確認。(如下圖)



5. 設置完成，開始烹調。

操作方法說明

■ 加強熱風對流+微波模式

建議使用之配件：

配件擺放位置：

於加強熱風對流的操作上加上微波以更短時間烤焗食物，減少烹調時間。適用烤焗體積較大的肉類及糕點。

	溫度	時間
開機預設	180°C	15 分鐘
設定範圍	80°C – 230°C	5 分鐘 – 3 小時 59 分鐘

 注意! 切勿在此煮食模式下使用金屬容器煮食 (建議使用之配件除外)，否則會產生火花，導致故障。
NO METAL

例如：設置烹調時間為 40 分鐘，溫度為 210°C。操作步驟：

1. 在待機狀態下，順時針旋轉旋鈕至  加強熱風對流+微波模式圖示閃爍，按旋鈕確認功能。(如下圖) 然後畫面會自動跳至小時選項。



2. 按旋鈕確認小時位 00 設定。(如下圖) 然後畫面會自動跳至分鐘選項。



3. 轉動旋鈕直到顯示分鐘轉至 40，按旋鈕確認。(如下圖) 然後畫面會自動跳至溫度選項。



4. 轉動旋鈕直到顯示溫度轉至 210°C，按旋鈕確認。(如下圖)



5. 設置完成，開始烹調。

操作方法說明

■ 全功能蒸焗模式

烤盤



建議使用之配件：

底層



配件擺放位置：

此模式集合上下火、熱風、蒸氣功能於一身，全功能的完美結合。煮食過程中加入蒸氣，讓烹調的食物不會因烤焗而流失水份。適用於煮各種食物。例如較大的肉類或烤焗濕潤的蛋糕。可把食物放在鋪有錫紙或牛油紙的焗盤上直接烤焗。每次使用前，請確保水箱已加滿水。

	溫度	時間
開機預設	180°C	20 分鐘
設定範圍	80°C – 230°C	5 分鐘 – 3 小時 59 分鐘

例如：設置烹調時間為 40 分鐘，溫度為 210°C

操作步驟：

1. 在待機狀態下，順時針旋轉旋鈕至  全功能蒸焗模式圖示閃爍，按旋鈕確認功能。(如下圖) 然後畫面會自動跳至小時選項。



2. 按旋鈕確認小時位 00 設定。(如下圖) 然後畫面會自動跳至分鐘選項。



3. 轉動旋鈕直到顯示分鐘轉至 40，按旋鈕確認。(如下圖) 然後畫面會自動跳至溫度選項。



4. 轉動旋鈕直到顯示溫度轉至 210°C，按旋鈕確認。(如下圖)



5. 設置完成，開始烹調。

操作方法說明

■ 全功能蒸焗+微波模式

建議使用之配件：

配件擺放位置：

此模式集合上下火、熱風、蒸氣、微波功能於一身，全功能的完美結合，加入微波更有助減少烹調時間。

	溫度	時間
開機預設	180°C	15分鐘
設定範圍	80°C – 230°C	5分鐘 – 3小時 59分鐘

 注意! 切勿在此煮食模式下使用金屬容器煮食 (建議使用之配件除外)，否則會產生火花，導致故障。
NO METAL

例如:設置烹調時間為 40 分鐘，溫度為 210°C。

操作步驟：

1. 在待機狀態下，順時針旋轉旋鈕至  全功能蒸焗+微波模式圖示閃爍，按旋鈕確認功能。(如下圖) 然後畫面會自動跳至小時選項。



2. 按順時針旋轉旋鈕確認小時位 00 設定。(如下圖) 然後畫面會自動跳至分鐘選項。



3. 按順時針旋轉旋鈕直到顯示分鐘轉至 40，按旋鈕確認。(如下圖) 然後畫面會自動跳至溫度選項。



4. 按順時針旋轉旋鈕直到頂部發熱管顯示溫度轉至 210°C，按旋鈕確認。(如下圖)



5. 設置完成，開始烹調。

操作方法說明

■ 保溫模式

建議使用之配件：

配件擺放位置：

以熱風保溫食物，適合將剛煮的食物保溫。

	食物重量	時間
開機預設	55°C	20 分鐘
設定範圍	50°C – 110°C	5 分鐘 – 6 小時 59 分鐘

例如：設置烹調時間為 1 小時 30 分鐘，溫度為 60°C。

操作步驟：

1. 在待機狀態下，順時針旋轉旋鈕至  保溫模式圖示閃爍，按旋鈕確認功能。(如下圖) 然後畫面會自動跳至小時選項。



2. 轉動旋鈕直到顯示小時位轉至 01，按旋鈕確認。(如下圖) 然後畫面會自動跳至分鐘選項。



3. 按旋鈕確認分鐘位 30 的設定。(如下圖) 然後畫面會自動跳至溫度選項。



4. 轉動旋鈕直到顯示溫度轉至 60°C，按旋鈕確認。(如下圖)



5. 設置完成，開始烹調。

操作方法說明

■ 乾果模式

建議使用之配件：

配件擺放位置：

以低溫熱風抽乾食物，適合製作各種生果片，蔬菜片或肉乾。

	溫度	時間
開機預設	60°C	20 分鐘
設定範圍	40°C – 90°C	5 分鐘 – 12 小時 59 分鐘

例如：設置烹調時間為2 小時，溫度為90°C。

操作步驟：

1. 在待機狀態下，順時針旋轉旋鈕至  乾果模式圖示閃爍，按旋鈕確認功能。(如下圖) 然後畫面會自動跳至小時選項。



2. 轉動旋鈕直到顯示小時位轉至02，按旋鈕確認。(如下圖) 然後畫面會自動跳至分鐘選項。

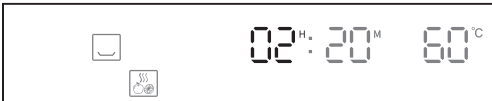

3. 按旋鈕確認分鐘位00 設定。(如下圖) 然後畫面會自動跳至溫度選項。



4. 轉動旋鈕直到顯示溫度轉至90°C，按旋鈕確認。(如下圖)



5. 設置完成，開始烹調。

操作方法說明

■ 慢煮模式

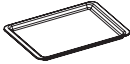
建議使用之配件：

配件擺放位置：

以蒸氣維持爐腔的溫度。以低溫慢煮，沒有經過高溫加熱，可使各種肉類和海鮮保存原有的鮮味。需配合真空袋使用。每次使用前，請確保水箱已加滿水。

	溫度	時間
開機預設	60°C	60 分鐘
設定範圍	50°C – 90°C	60 分鐘 – 12 小時 59 分鐘

例如：設置烹調時間為 1 小時 40 分鐘，溫度為 60°C。

操作步驟：

1. 在待機狀態下，順時針旋轉旋鈕至  慢煮模式圖示閃爍，按旋鈕確認功能。(如下圖) 然後畫面會自動跳至小時選項。



2. 按旋鈕確認小時 01。(如下圖) 然後畫面會自動跳至分鐘選項。



3. 轉動旋鈕直到顯示分鐘轉至 40，按旋鈕確認。(如下圖) 然後畫面會自動跳至溫度選項。



4. 按旋鈕確認默認溫度 60°C 的設定。(如下圖)



5. 設置完成，開始烹調。

操作方法說明

■ 發酵模式

建議使用之配件：

配件擺放位置：

此模式以蒸氣運作，使爐腔達至已調校的穩定而潮濕的環境。用於麵糰發酵：如薄餅的餅底或製作麵包的麵糰。麵糰發酵速度會較室溫下快，麵糰表面也不會過乾。每次使用前，請確保水箱已加滿水。

	溫度	時間
開機預設	35°C	40分鐘
設定範圍	25°C – 50°C	5分鐘 – 12小時 59分鐘

例如：設置烹調時間為 40 分鐘，溫度為 35°C。

操作步驟：

1. 在待機狀態下，逆時針旋轉旋鈕至  發酵模式圖示閃爍，按旋鈕確認功能。(如下圖) 然後畫面會自動跳至小時選項。



2. 按旋鈕確認小時位 00 設定。(如下圖) 然後畫面會自動跳至分鐘選項。



3. 轉動旋鈕直到顯示分鐘轉至 40，按旋鈕確認。(如下圖) 然後畫面會自動跳至溫度選項。



4. 按旋鈕確認溫度。



5. 設置完成，開始烹調。

操作方法說明

■ 翻熱麵包模式

建議使用之配件：

配件擺放位置：

此程式會以已調節的最佳溫度去翻熱麵包，過程中加入蒸氣，使效果像剛出爐的新鮮麵包。備有兩種模式.. 室溫 麵包或冷藏麵包。每次使用前，請確保水箱已加滿水。
建議烹調時間：一般冷藏麵包所需翻熱時間大約是 10–15 分鐘;室溫麵包麵包所需翻熱時間大約是 8–13 分鐘。如果有餡的麵包要再加多 5–10 分鐘。此建議烹調時間僅供參考。客人需因應麵包份量、大小、種類和個人喜好 等自行調整翻熱時間。

	溫度	時間
開機預設	180°C	10 分鐘
設定範圍	不可調校	5 分鐘 – 59 分鐘

例如：烹調從雪櫃取出的麵包，設置烹調時間為 25 分鐘。

操作步驟：

1. 在待機狀態下，順時針旋轉旋鈕至  翻熱麵包模式圖示閃爍，按旋鈕確認功能。(如下圖) 然後畫面會自動跳至分鐘選項。



2. 轉動旋鈕直到顯示分鐘轉至 25，按旋鈕確認。(如下圖)



3. 設置完成，開始烹調。

操作方法說明

■ 解凍模式

建議使用之配件：

配件擺放位置：

用於解凍冷藏或冷凍食物。

	食物重量	時間
開機預設	500g	7 分鐘 40 秒
設定範圍	100g – 2000g	跟據食物重量自動調校

 注意! 切勿在此煮食模式下使用金屬容器煮食 (建議使用之配件除外)，否則會產生火花，導致故障。
NO METAL

例如：設置解凍600g食物。

1. 待機狀態下，逆時針旋轉旋鈕至  解凍模式圖示閃爍，按旋鈕確認功能。(如下圖) 然後畫面會自動跳至食物重量選項。



2. 轉動旋鈕，直至重量數值顯示600，按旋鈕確認。(如下圖)



3. 設置完成，開始烹調。

操作方法說明

■ 預熱模式

預熱模式有蒸氣和烤焗兩種預熱模式選擇，使爐腔達至預設溫度。

	蒸氣預熱	烤焗預熱
	溫度	溫度
開機預設	100°C	180°C
設定範圍	50°C – 110°C	100°C – 230°C

兩種預熱功能的烹調時間均毋需設定；當達到設定的預熱溫度時，顯示屏會顯示“END”和發出聲效提示操作已完成。預熱進行中，顯示之時間為現在時間。如進行蒸氣預熱，每次使用前，請確保水箱已加滿水。

蒸氣預熱

例如：以蒸氣進行預熱，設置烹調溫度為 100°C。

操作步驟：

1. 在待機狀態下，順時針旋轉旋鈕至  預熱模式圖示閃爍，預設的預熱模式是蒸氣模式，按旋鈕確認功能。(如下圖)



2. 轉動旋鈕直到顯示溫度轉至100°C，按旋鈕確認。(如下圖)



3. 設置完成，開始預熱。

操作方法說明

烤焗預熱

例如：以烤焗進行預熱，設置烹調溫度為 200°C。

操作步驟：

1. 在待機狀態下，順時針旋轉旋鈕至預熱模式圖示閃爍，預設的預熱模式是蒸氣模式，轉動旋鈕切換至烤焗預熱模式，按旋鈕確認功能。（如下圖）



2. 此時自動進入烹調溫度的設置；轉動旋鈕直到顯示溫度轉至 200°C，按旋鈕確認。（如下圖）



3. 設置完成，開始預熱。

預熱結束時，顯示屏顯示會“END”及發出聲效提示操作已完成。預熱完成後，客人可以根據需要，選擇其他烹調模式進行烹調。

注意：“烹調過程中調校 / 結束後追加時間功能”功能不適用於此模式。

操作方法說明

■ 氣炸模式

建議使用之配件：

配件擺放位置：

以風扇將熱力在爐腔內運行產生對流以較短時間烤焗食物造出香脆效果。適用於需要氣炸的食物或烤焗體積較大的肉類及糕點。

	溫度	時間
開機預設	180°C	25 分鐘
設定範圍	80°C – 230°C	5 分鐘 – 3 小時 59 分鐘

例如：設置烹調時間為 30 分鐘，溫度為 210°C。

操作步驟：

1. 在待機狀態下，順時針旋轉旋鈕至  氣炸模式圖示閃爍，按旋鈕確認功能。(如下圖) 然後畫面會自動跳至小時選項。



2. 按旋鈕確認小時位 00 設定。(如下圖) 然後畫面會自動跳至分鐘選項。



3. 轉動旋鈕直到顯示分鐘轉至 30，按旋鈕確認。(如下圖) 然後畫面會自動跳至溫度選項。



4. 按旋鈕確認默認溫度 210°C 的設定。(如下圖)



5. 設置完成，開始烹調。

操作方法說明

■ 烘乾爐腔模式

此模式會以高溫加熱爐腔，蒸發爐腔中多餘水份及蒸氣。此功能適用於任何以蒸氣烹調的模式後使用。

	溫度	時間
開機預設	180°C	15 分鐘
設定範圍	不可調校	不可調校

操作步驟：

1. 在待機狀態下，逆時針旋轉旋鈕至  烘乾爐腔模式圖示閃爍。(如下圖)



2. 按旋鈕確認功能，開始烹調。(如下圖)



操作方法說明

■ 除垢模式

長期使用蒸氣功能會導致機內及水管內產生水垢。

當累積使用蒸氣模式或其他帶有蒸氣功能模式的時間達到100個小時，顯示屏上  除垢提示圖示會亮起，提醒用戶進行除垢模式。直至用戶啟動除垢模式後，圖示才會熄滅。

除垢模式分兩個階段，除垢階段、清洗階段。當需要倒掉接水盤內的污水時，顯示屏上  會相應亮起來提醒用戶。

除垢模式需配合除垢劑使用。客人可選用惠而浦獨家推出的Wpro除鈣去垢劑，此產品適用於蒸爐，有效清空蒸爐管道內的鈣化聚積物和保持機器良好的操作性能。詳情可到惠而浦有限公司網站了解。網址請查看說明書之封面。

進行除垢模式時，建議使用除垢劑和淨水分量如下：

第 1 階段：除垢，時間為 56 分鐘。建議使用 30 毫升除垢劑和 300 毫升淨水。

第 2 階段：除垢清潔，時間為 4 分鐘。建議使用 300 毫升淨水。

	溫度	時間
開機預設	不可調校	60 分鐘
設定範圍	不可調校	不可調校

操作步驟：

1. 第 1 階段：除垢

A. 先將 30 毫升除垢劑和 300 毫升淨水倒入水箱。

B. 在待機狀態下，逆時針轉動旋鈕至  除垢模式圖示亮起，按旋鈕確認功能。（如下圖）



C. 開始除垢模式。（如下圖）



D. 第 1 個階段需時 56 分鐘，程式完成後，顯示屏上的時間位會閃動，並發出聲效去提示第 1 個階段完成。

同時顯示屏上  接水盤圖示會亮起，提醒用戶倒掉接水盤內的污水。



E. 請倒掉污水，並將接水盤放回機內。

操作方法說明

2. 第 2 個階段：除垢清潔

A. 打開爐門，將 300 毫升淨水倒入水箱。

B. 將水箱放回機內並關上爐門，按旋鈕確認，程式會再次啟動，繼續除垢清潔工作。



C. 第 2 個階段完成後，顯示屏會顯示“End”提示，並發出聲效提示，同時顯示屏上提醒用戶倒掉接水盤內的污水。



D. 請倒掉污水。

3. 除垢完成。

注意：1. 組合鍵：“爐腔溫度顯示”功能不適用於此模式。

2. “烹調過程中調校 / 結束後追加時間”功能不適用於此模式。

3. 除垢過程中，如操作有誤（包括操作過程中按暫停或沒有按指示下開關爐門等），除垢模式程式會被擾亂而無法正常運作。建議重新啟動除垢模式並按照除垢模式中的指示再次操作。

操作方法說明

■ DIY 煮食模式

用於一次性自動完成多種不同的煮食功能組合模式，使食物製作更多樣化和方便。

例如：先用蒸氣模式溫度 110°C 烹調時間 1 小時 20 分鐘，結束後接着用加強熱風對流+微波模式溫度 190°C 烹調時間 1 小時 30 分鐘，結束後再以熱風模式溫度 190°C 烹調時間 1 小時 30 分鐘。

操作步驟：

1. 在待機狀態下，順時針旋轉旋鈕至  模式圖示閃爍，按旋鈕確認功能。(如下圖) 然後畫面會跳至煮食模式選項。



2. 順時針旋轉旋鈕至  蒸氣模式圖示閃爍，按旋鈕確認功能 (如下圖) 然後畫面會自動跳至小時選項。



3. 按旋鈕確認小時位 01 設定。(如下圖) 然後畫面會自動跳至分鐘選項。



4. 順時針旋轉旋鈕直到顯示轉至 20，按旋鈕確認。(如下圖) 然後畫面會自動跳至溫度選項。



5. 順時針旋轉旋鈕直到顯示溫度轉至 110°C，按  認並跳至下一個設定模式。(如下圖)



6. 順時針旋轉旋鈕至  加強熱風對流+微波模式圖示閃爍，按旋鈕確認功能 (如下圖) 然後畫面會自動跳至小時選項。



7. 按旋鈕確認小時位 01 設定。(如下圖) 然後畫面會自動跳至分鐘選項。



操作方法說明

8. 順時針旋轉旋鈕直到顯示轉至 30，按旋鈕確認。(如下圖) 然後畫面會自動跳至溫度選項。



9. 順時針旋轉旋鈕直到顯示溫度轉至 190°C，按  確認並跳至下一個設定模式。(如下圖)



10. 順時針旋轉旋鈕至加強熱風對流模式圖示閃爍，按旋鈕確認功能 (如下圖) 然後畫面會自動跳至小時選項。



11. 按旋鈕確認小時位 01 設定。(如下圖) 然後畫面會自動跳至分鐘選項。



12. 順時針旋轉旋鈕直到顯示轉至 30，按旋鈕確認。(如下圖) 然後畫面會自動跳至溫度選項。



13. 順時針旋轉旋鈕直到顯示溫度轉至 190°C，按旋鈕確認並完成設定。



14. 設置完成，開始烹調。

操作方法說明

■ 烹調過程中調校 / 結束後追加時間功能

A. 烹調過程中進行調校



在烹調過程中，可以根據需要去增加或減少烹調時間和溫度。

例如：已設定的烹調時間 01:40 和溫度 90°C，改為烹調時間 02:00 及溫度 100°C。

操作步驟：

1. 於烹調過程中，按旋鈕暫停烹調，時間位會閃爍。(如下圖)



2. 按設置鍵 ，自動進入調較設置，小時位會閃爍；顯示屏上  增加烹調時間圖示會亮起。(如下圖)



3. 轉動旋鈕直到顯示小時位轉至 02，按設置鍵  確認。(如下圖) 然後畫面會自動跳至分鐘選項。



4. 轉動旋鈕直到顯示分鐘轉至 00，按設置鍵  確認。(如下圖) 然後畫面會自動跳至溫度選項。



5. 轉動旋鈕直到顯示溫度轉至 100°C，按旋鈕確認。(如下圖)



6. 設置完成，開始新設置的烹調設定。

操作方法說明

B. 烹調過程結束後追加功能

在烹調過程結束後，可以根據需要去增加烹調時間。

	溫度	時間
設定範圍	不可調校	1 分鐘 – 59 分鐘

烹調過程結束後，顯示屏會顯示“End”並發出聲效提示。同時顯示屏上  增加烹調時間圖示會亮起。

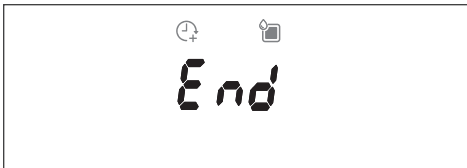

如增加烹調時間，可根據以下步驟操作：

例如：烹調結束後，追加烹調時間 3 分鐘。

操作步驟：

1. 按旋鈕確認追加時間功能，顯示屏會自動跳至分鐘位選項。(如下圖)



2. 轉動旋鈕直到顯示分鐘轉至 03，按旋鈕確認。(如下圖)



3. 設置完成，即啟動追加時間烹調。(如下圖)



注意：如果用戶在烹調結束後，5 分鐘內沒有進行任何操作，將自動返回到待機狀態。

操作方法說明

■ 預約功能

在進行預約功能設定前，必須先完成時鐘設定。時鐘設定可參見本說明書第 15 頁“設置時鐘”內說明。
例如：現時時間為 12:00，設置預約蒸氣模式，烹調時間為 1 小時 40 分鐘，溫度為 90°C，結束時間為 14:00。

操作步驟：

1. 在待機狀態下，順時針旋轉旋鈕至  蒸氣模式圖示亮起，按旋鈕確認功能。(如下圖) 然後畫面會自動跳至小時選項。



2. 按旋鈕確認小時位 01 設定。(如下圖) 然後畫面會自動跳至分鐘選項。



3. 轉動旋鈕直到顯示分鐘轉至 40，按旋鈕確認。(如下圖) 然後畫面會自動跳至溫度選項。



4. 轉動旋鈕直到顯示溫度轉至 90°C，按設置鍵  3秒確認。(如下圖)



5. 轉動旋鈕直到小時位轉至14，按旋鈕確認。(如下圖) 然後畫面會自動跳至分鐘選項。



6. 轉動旋鈕直到分鐘位轉至40，按旋鈕確認。(如下圖)



7. 顯示屏上  預約功能圖示會亮起，預約烹調時間切換回現時時間12:00。表示預約設置完成。(如下圖)



操作方法說明

A. 查詢預約狀態

可按設置鍵  3 秒，以查詢預約結束時間，預約功能圖示會顯示；再按設置  3 秒，可返回預約設置畫面。

B. 取消預約設定：

如需取消預約設定，可直接按  電源鍵，即退出預約設定，並自動返回到待機畫面。

注意：預約模式適用於 12 個主要烹調模式，翻熱麵包模式，慢煮模式和乾果模式。（詳情請參閱第 8-11 頁控制面板 – 主要功能介紹 / 詳細說明）

建議：預約設置後，可啟動兒童安全鎖功能，以防止不小心觸摸到控制面板而誤將預約取消。童鎖設置可參見本說明書第 7 頁“控制面板 – 基本功能說明”內說明。當達到預約的啟動時間，蒸焗爐會正常啟動，不受童鎖影響。

操作方法說明

■ 自動菜單

待機狀態下，按  進入自動菜單功能設定，旋轉旋鈕，選擇菜單號，按旋鈕中鍵確認；



自動菜單編號	菜單名稱	食譜	食物盤位置
P01	清蒸鱸魚	鱸魚500g、薑6片、蔥6段、醬油20ml、油50ml 1. 鱸魚清潔乾淨後，用油和黑胡椒粉醃製半小時； 2. 碟底放薑蔥，鱸魚放入碟中； 3. 放入微蒸烤焗爐頂層，選擇P01； 4. 出爐後、倒掉碟子的汁，倒入醬油，淋入熱油。	頂層
P02	蒜蓉娃娃菜	娃娃菜400g、大蒜、醬油30ml、鹽1茶匙、油70g、蠔油10g 1. 娃娃菜對半切開，各自切成6小塊，平鋪在碟子上； 2. 蒜剝成蒜蓉，加入調味料，熱油淋面，調成蒜蓉醬汁； 3. 醬汁淋到娃娃菜上方； 4. 放入微蒸烤焗爐頂層，選擇P02	頂層
P03	白貝蒸水蛋	雞蛋2隻，常溫水200ml，白貝16隻，薑片，米酒，鹽、醬油、油適量 1. 白貝用鹽水浸泡，加入適量油，浸泡1小時； 2. 鍋燒熱水，加入薑片、米酒，倒入白貝，微微開殼即可撈出； 3. 雞蛋加入適量鹽，攪拌均勻，再倒入常溫水，攪拌均勻； 4. 白貝放入淺盤底，開口朝上，倒入蛋液； 5. 放入微蒸烤頂層，選擇P03； 6. 出爐撒上蔥花，淋上醬油、熱油即可。	頂層
P04	蒸米飯	米50g、水370ml 1. 米洗乾淨，倒入烤盤中，倒入清水； 2. 放入微蒸烤焗爐頂層，選擇P04；	頂層
P05	脆皮烤肉	五花肉700g、鹽2匙、五香粉2匙、白醋1匙、小蘇打1匙 1. 五花肉表皮用火槍燒豬毛，用刀刮乾淨； 2. 肉麵開深槽，撒上五香粉和鹽，除了豬皮以外，每面都要塗抹均勻； 3. 豬肉冷水下鍋，煮出浮沫，過冷水； 4. 豬皮搽乾淨，用小尖刀戳洞，密密的戳透皮層； 5. 盤底倒入適量白醋，豬皮朝下泡5分鐘； 6. 豬皮朝上，其他幾面用錫紙包裹，放入冰箱冷藏一晚，直到豬皮表面乾燥； 7. 放入微蒸烤焗爐頂層，選擇P05即可	頂層
P06	蜜汁雞翼	雞翼12隻、醃雞翼粉70g、蒜蓉20g、粟粉30g、蜂蜜適量、油適量 1. 雞翼洗乾淨，清水浸泡20分鐘，瀝乾； 2. 倒入粟粉，再倒入調味料拌勻，醃1小時； 3. 雞翼平鋪烤盤，放入微蒸烤焗爐頂層，選擇P06，即可	頂層

操作方法說明

自動菜單編號	菜單名稱	食譜	食物盤位置
P07	烤羊排	<p>羊排5件，洋蔥1個、大蔥3段、薑6片、鹽1茶匙、生抽2匙、米酒1匙、蜂蜜1匙、孜然粉4茶匙、大蒜粉2茶匙、白胡椒粉1茶匙、紅辣椒粉1茶匙</p> <ol style="list-style-type: none"> 1. 羊排加入蔥、薑、鹽、生抽、米酒、蜂蜜醃製2小時； 2. 粉類調味料混合均勻，製成醃料； 3. 洋蔥切成段墊底，放上羊排； 4. 羊排兩面都要均勻塗上醃料； 5. 放入微蒸烤焗爐頂層，選擇P07； 6. 剩餘10分鐘，把羊排翻面繼續烤，即可 	頂層
P08	漢堡扒	<p>牛肉碎200g、豬肉碎150g、洋蔥半個(切碎)、雞蛋 1 隻</p> <ol style="list-style-type: none"> 1. 把所有漢堡材料和醃料拌勻，並壓成扒型。 2. 把漢堡扒放烤盤上，放入微蒸烤焗爐頂層，選擇P08即可 	頂層
P09	叉燒	<p>豬梅頭肉 400-500g 調味料：鹽 1 湯匙、糖 4 湯匙、雞粉 1/4 茶匙、雞蛋 1 隻、乾蔥 2 粒、蒜 2 瓣、芫茜頭1 棵、豆豉 1 湯匙(剁碎)、玫瑰露酒 1/2 茶匙、麥芽糖4湯匙、薑蓉少量</p> <ol style="list-style-type: none"> 1. 準備醃肉調味料。先爆香乾蔥、蒜蓉、芫茜頭及豆豉。再加入糖、鹽、天然雞粉及雞蛋。拌勻後室溫發酵 6 小時。 2. 第二天，將玫瑰露酒混入發酵好的調味料內，醃半小時或以上。梅頭肉切成長塊狀。 3. 將調味料加入梅肉頭肉中，醃 45 分鐘至 1 小時。 4. 放醃好之梅頭肉在烤盤上，放入微蒸烤焗爐頂層，選擇 P06，即可 5. 烤焗完成後取出叉燒，以已用水煮溶之麥芽糖塗在叉燒上。 6. 再放入蒸焗爐以「上下燒烤」模式焗 15 分鐘。再取出在另一面塗麥芽糖，繼續焗 15 分鐘即成。 	頂層
P10	烱蛋	<p>雞蛋 4 隻</p> <ol style="list-style-type: none"> 1. 將雞蛋放在蒸盤上，放入微蒸烤焗爐底層，選擇P10，即可 	下層
P11	烤粟米	<p>粟米 2 條 調味料：橄欖油 2 匙、小茴香粉 2 茶匙、芝士粉 1 茶匙、鹽 1 茶匙、黑胡椒 1 茶匙</p> <ol style="list-style-type: none"> 1. 粟米分成3段，每段切成4塊； 2. 將調味料部混合拌勻，備用； 3. 粟米平鋪在烤盤上，塗抹上調味料； 4. 放入微蒸烤焗爐頂層，選擇P11，即可； 	頂層
P12	烤番薯	<p>蕃薯 3 個 (每個約100g)</p> <ol style="list-style-type: none"> 1. 蕃薯清洗乾淨後，放入烤盤； 2. 將烤盤放入微蒸烤焗爐頂層，選擇P12，即可； 	頂層
P13	氣炸薯條	<p>急凍薯條200g</p> <ol style="list-style-type: none"> 1. 急凍薯條無需解凍倒入氣炸籃中，盡量避免堆疊； 2. 放入微蒸烤焗爐頂層，選擇P13，即可； 	頂層
P14	白麵包	<p>小麵包 麵包粉250g、即溶酵母3g、鹽5g、糖18g、無鹽奶油30g、牛奶220ml</p> <ol style="list-style-type: none"> 1. 無鹽奶油室溫軟化。 2. 將麵包粉、即溶酵母、鹽、糖和牛奶放入攪拌機中攪拌 20分鐘。 3. 將軟化的無鹽奶油加入麵團中，攪拌約 15分鐘。 4. 將麵團切成12等份。 5. 烤盤上鋪上烘焙紙，將 6個麵團放在烤盤上，放入微波蒸烤爐底層，選擇 P14。 	底層

操作方法說明

自動菜單編號	菜單名稱	食譜	食物盤位置
P15	意大利薄餅	<p>高筋麵粉250g、水150ml、鹽 4 克、速酵 1/2 克、紅椒適量、九層塔適量、芝士適量、烤雞肉適量</p> <ol style="list-style-type: none"> 1. 把鹽放入水內溶解，加入10% 的麵粉拌勻，然後加入速酵並拌勻。 2. 分數次加入剩餘的麵粉，並用手搓成圓形麵團。 3. 用半乾濕布鋪蓋麵團，放於室溫稍息。 4. 排氣並滾圓，然後放入雪櫃過夜發至兩倍大。 5. 從雪櫃取出麵團後，需室溫回暖一小時。 6. 搓成12 吋薄餅形狀，放上紅椒、九層塔、芝士及烤雞肉。 7. 將薄餅放在烤盤上，放入微蒸烤焗爐底層，選擇P15，即可； 	底層
P16	酸奶	<p>純牛奶750ml、原味乳酪50ml、砂糖40g</p> <ol style="list-style-type: none"> 1. 製作乳酪的器具必須用開水燙煮，風乾，確保無油無水； 2. 純牛奶加熱至40度左右關火，加熱砂糖攪拌均勻； 3. 牛奶溫度低於40度後，加入優格做酵母，攪拌均勻； 4. 放入優格發酵盤，用保鮮膜或蓋子密封； 5. 放入微蒸烤焗爐底層，選擇P16，即可； 	底層
P17	藍莓忌廉芝士鬆餅	<p>藍莓120g、雞蛋2 隻、白糖150g、菜油 50g、雲尼拿油 1/2 茶匙、酸忌廉220g、低筋麵粉250g、鹽1/2茶匙、梳打粉 1/2 茶匙、忌廉芝士少許</p> <ol style="list-style-type: none"> 1. 將藍莓洗淨，備用。 2. 先將雞蛋和白糖放進大碗內，用電動打蛋器打至淡黃色。加入菜油和雲尼拿油攪拌均勻，最後加入酸忌廉拌成蛋液。 3. 把低筋麵粉、鹽和梳打粉用濾網過篩。 4. 把已過篩的粉類加入蛋液中，再加入藍莓。 5. 將蛋液倒入鬆餅模裡，約杯的7 成滿，加上忌廉芝士。 6. 將焗盤放入微蒸烤焗爐底層，選擇P17，即可； 	底層
P18	蘋果批	<p>批皮材料: 無鹽牛油90g、糖 1 茶匙、鹽3g、中筋麵粉180g、蛋黃 2 隻、冰水 2 湯匙、蛋白 1 隻</p> <p>餡料: 紅 / 青蘋果各 6 個、檸檬汁 1 茶匙、檸檬絲半個、荳蔻粉少許、黃金蔗糖 1 茶匙、合桃或杏仁片少許、櫻桃乾少許</p> <ol style="list-style-type: none"> 1. 製作批皮，將無鹽牛油、糖和鹽拌至軟身。加入中筋麵粉略拌，放入蛋黃和冰水。 2. 攪拌成光滑麵糰後，用桿麵棍輕輕壓扁至方形狀。用保鮮紙包好放入雪櫃冷藏至少1 小時。 3. 取出批皮，室溫靜置30 分鐘。然後將批皮置於 2 張牛油紙之間，擀成5 公分厚後撕去牛油紙。 4. 將批皮放入 10 吋模具中，用叉刺孔，在批皮四周塗上蛋白。放回雪櫃冷藏。 5. 製作餡料，把紅蘋果和青蘋果洗淨切片，加入檸檬汁、檸檬絲、荳蔻粉和黃金蔗糖拌勻，然後以細火煮至軟身，用濾網隔走水份，待涼。 6. 用桿麵棍將合桃或杏仁片略略壓碎，加入櫻桃乾；然後倒入餡料內再拌勻。 7. 從雪櫃中取出批底，將餡料平均倒入批底，掃上少許蛋漿。將蘋果批放入微蒸烤焗爐頂層，選擇P18，即可； 	頂層
P19	解凍冰鮮(500g)		爐腔底部
P20	半解凍肉類(500g)		爐腔底部
P21	全解凍肉類(500g)		爐腔底部

操作方法說明

■ 餘溫高溫提示 H

在待機狀態或省電模式狀態下，完成煮食後，只要爐腔內的溫度高於50°C，顯示屏上 H 高溫提示圖標就會亮起，提醒用戶爐腔內溫度較高，不適宜進行清潔。直到爐腔內的溫度低於50°C，顯示屏上高溫提示圖標才會消失，建議用戶於圖示消失後才進行清潔。

■ 童鎖功能

用來鎖住按鍵，防止兒童在沒有成人指導的情況下使用微蒸烤焗爐。

A. 啟動童鎖

可長按  童鎖鍵 3 秒鐘，進入童鎖狀態，此時顯示屏上方的童鎖圖示亮起。（如下圖）



B. 解除童鎖

長按  童鎖鍵 3 秒鐘，即可解除童鎖，此時顯示屏上方的童鎖圖示會消失。

■ 清潔保養

1. 在正常情況下，清潔產品是唯一所需的保養方法。
2. 請務必在微蒸烤焗爐冷卻狀態下，H 圖示消失後進行清潔與保養。清潔之前，需切斷電源。請勿使用蒸氣清潔器清洗本蒸焗爐。
3. 微蒸烤焗爐必須保持清潔，否則可能導致爐身受到腐蝕，縮短微蒸烤焗爐的使用壽命，所以每次使用微蒸烤焗爐後，必須進行清潔。
4. 切勿使用含金屬成份的清潔布、磨砂型潔具、鋼刷、表面粗糙的抹布，否則會對爐身表面、爐門、控制面板、爐內壁及配件造成損害。應以沾有溫和洗潔精的海綿或軟布或噴上玻璃清潔劑的廚房紙巾進行清潔。每次使用後，確保爐腔（包括爐腔底部）是乾透。
5. 鹽份是具侵蝕性的物質，一旦積聚在爐腔內，將形成銹漬。一些帶酸性的醬汁，例如茄汁、芥末和醃製食品含有氯和酸的化學成份。而該等成份會對鋼表面造成影響。所以建議每次使用微蒸烤焗爐後，必須進行清潔。
6. 切勿讓油脂及食物碎屑殘留於爐門及爐門封邊上。假如爐門封邊清潔處理不善，或會影響微蒸烤焗爐操作時，爐門無法完全關上，繼而導致機前方及兩側部份損壞。
7. 每次使用後，
 - i) 清理微蒸烤焗爐門底下接水盤的積水，以防止積水滿瀉，濺濕及弄髒檯面。(接水盤是可以拆下的。它會盛載每次蒸煮後玻璃門開門時滴下的倒汗水。)
 - ii) 清理殘留在水箱未用完的水。
 - iii) 每次使用後，打開爐門 15–30 分鐘或進行烘乾爐腔模式，以風乾爐腔及門框。
8. 如果爐腔非常骯髒，可於清潔前，先以「消毒模式」(110°C)，蒸煮 30 分鐘，來溶解油漬，待機身冷卻後，才開始進行清潔。如遇上頑固的油漬，可重覆以上的步驟。切勿使用含金屬成份的清潔布、磨砂型潔具、鋼刷、表面粗糙的抹布清潔。
9. 建議最少每一個月或除垢圖示亮起時進行“除垢模式”清潔。
10. 建議使用直接從水喉取的自來水、飲用食水或蒸餾水作烹調用，但避免使用礦泉水。
11. 水箱必須每月至少檢查一次。如有需要，取出水箱，擦洗乾淨後再放回原處。
12. 若長時間不使用本產品時，應拔掉電源插頭，保持爐腔清潔，並將蒸焗爐放置在通風、乾燥及沒有腐蝕性氣體的環境中。
13. 每次使用後，應清潔和風乾爐腔(包括爐腔頂部，左右兩側和底部)。如爐底或爐腔有變黃的情況，可以使用不銹鋼清潔劑去除污漬。(例如：Wpro 不銹鋼清潔劑)

清潔及保養

■ 清潔及保養

⚠ 警告



在拔下電源插頭並等待爐體充分冷卻後，才進行爐體保養。

拔下插頭
充分冷卻

否則可能會導致觸電，傷害或燙傷。

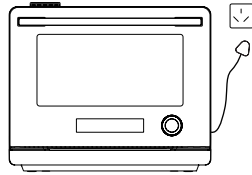

請勿用濕手插拔電源插頭

禁止

否則可能會導致觸電。



嚴禁將微蒸焗爐浸入水中或其他液體中

禁止

否則可能會導致觸電，傷害。

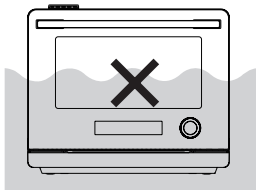

請勿在微蒸焗爐內或門上附著油或食物殘渣的情況下進行加熱

禁止

微波會集中在髒污部分，可能引起火花、煙霧、火災等危險。另外，會出現生鏽。

●若附著髒污時，請務必每次在爐腔冷卻後進行清潔。

⚠ 注意



禁止

請不要使用家用洗滌劑（鹼性、酸性等）、烤箱清潔劑、粉末清潔劑、苯乙烯、稀釋液、漂白水、熱水、可燃性瓦斯（LPG等）噴霧清潔劑、百潔布、海綿堅硬部分、金屬清潔劑等。

海綿百潔布



請不要使用堅硬部分
(附粗糙面的不織布)

請使用海綿部位進行清洗

粗糙面的百潔布



請不要使用這類型
百潔布來進行清洗
請使用不帶粗糙面
的清潔用品

清潔及保養

■ 清潔及保養

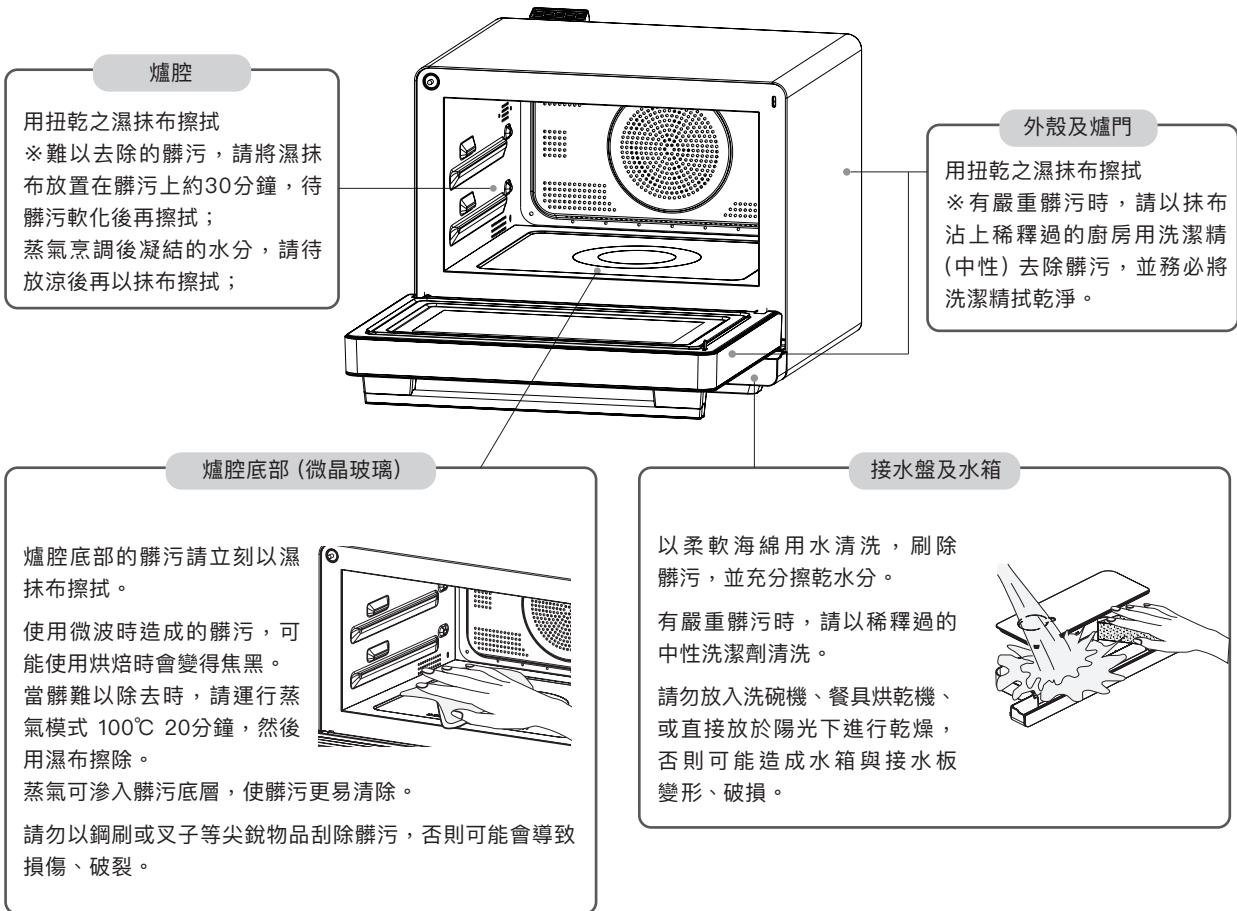

其他須知

■ 故障排解

A. 如出現以下情況

	如以下情況出現...	可能成因	解決方法
1	顯示屏上顯示消失	微蒸烤焗爐沒有連接到電源	確保微蒸烤焗爐連接電源
		插座有問題	用其他電器再測試插座是否有問題
		電源線不能正常工作	與客戶服務部聯絡
2	微蒸烤焗爐不能操作	電源插頭沒有插好	重新插好電源插頭
		爐門沒有關好	重新關閉爐門
		水箱沒有放置妥善	重新放回水箱並妥善安裝
		電路版損壞	與客戶服務部聯絡
		兒童安全鎖被鎖住	解除兒童安全鎖
3	顯示屏顯示異常	顯示屏損壞	與客戶服務部聯絡
		電路板損壞	
4	烹調期間大量排出水或蒸氣	爐門沒有關上	重新把爐門關上
		爐門封邊損壞	與客戶服務部聯絡
5	爐燈不亮	爐燈損壞	與客戶服務部聯絡
		主機電腦板損壞	
6	風扇不能正常運作	風扇電機損壞	與客戶服務部聯絡
		主機電腦板損壞	
7	按鍵失靈	導電橡膠按鍵裝置錯誤或損壞	與客戶服務部聯絡
		主機電腦板損壞	
8	無蒸氣噴出	水管被折疊、堵塞或損壞	與客戶服務部聯絡
		水泵損壞	
		水箱內無水或水箱沒有放置妥善	
9	微蒸烤焗爐漏水	沒有把儲水箱完整推進到位	請將水箱加滿水並妥善安裝

其他須知

B. 下列情況均屬正常

	情況	原因
1	首次使用各種燒烤或烤焗模式時，蒸焗爐有少量白煙冒出及異味。	這是由爐腔裡保護部件的過多油脂揮發所引起的。這屬於正常現象，非損壞。
2	使用蒸氣相關功能時有聲音	水箱吸水時或會混入空氣造成聲音，是正常現象。
3	蒸氣凝結在出風口或蒸氣從爐門四周縫隙處溢出	使用與蒸氣相關的功能時，蒸焗爐運轉過程中爐腔內會產生大量蒸氣，爐腔內多餘的蒸汽會通過出風口排出，但少部分蒸汽由於環境溫度，會凝結在出風口口處，或部分蒸氣可能從門縫四周漏出，這是正常現象。
4	烹調結束後風扇仍在工作	某些烹調程式結束後，風扇會延時工作 3 分鐘，將腔體內的熱量排出。這是產品冷卻爐腔和電子元件，屬於正常現象。
5	如發現有白色粉末在入氣口流出	這是水垢，是正常現象。如發現白色粉末（水垢），請啟動除垢模式，以清潔水管。
6	如爐腔 / 爐底有變黃現象	不鏽鋼受熱後，如清潔處理不善，會產生變黃現象。建議每次使用蒸焗爐後，進行清潔以避免變黃現象產生。
7	電壓波動，會影響煮食效果	當電壓在-10%至+5%的範圍波動時，微蒸焗爐仍能運作，但受電壓偏低或偏高的影響，輸出功率相對降低或升高，影響煮食效果，這是正常現象。

其他須知

■ 產品規格

型號	MWP269TMS
額定電壓及額定頻率	220-240V~ 50/60Hz
額定輸入功率	2100 W
額定微波輸入功率	1500 W
頻率	2450 MHz
產品尺寸(高 × 闊 × 深) (不包括手柄)	367 x 450 x 458毫米
爐腔尺寸(高 × 闊 × 深)	201.5 x 380 x 320毫米
爐腔容積	26 L
淨重	約 19 kg

Table of Contents

■ General Preparation and Advice before Use

	Page
Important Safety Information	58
Precautions before First Use	58
Precautions and Advice	58-59
Mounting the Appliance	60
Earthing Instructions	60
Appliance and Accessories Chart	61-62
Water tank and drip tray	63
Control Panel	63
Control Panel – Basic Functions	64
Control Panel – Major Features	65
Control Panel – Description of Major Features	66-68
Use and Cooking Tips	69
Recommended Recipes	70-71

■ Operation Instructions

	Page
Setting the Clock	72
Microwave Mode	73
Steam Mode	74
Steam + Microwave Mode	75
Upper Grill Mode	76
Upper Grill + Microwave Mode	77
Bottom Grill Mode	78
Conventional Bake Mode	79
Conventional Bake + Microwave Mode	80
Convection Mode	81
Turbo Convection Mode	82
Turbo Convection + Microwave Mode	83
Convection + Steam Mode	84
Convection + Steam + Microwave Mode	85

	Page
Keep Warm Mode	86
Drying Fruit Mode	87
Slow Cook Mode	88
Proving Mode	89
Bread Reheat Mode	90
Defrost Mode	91
Preheat Mode	92-93
Air Fry Mode	94
Cavity Drying Mode	95
Descaling Mode	96-97
DIY Cooking	98-99
Adjust or Increase the Cooking Time	100-101
during / After Cooking is Completed	
Preset Function	102-103
Auto Menu	104-107
Residual Heat Indicator	108
Child Lock	108

■ Cleaning and Maintenance

	Page
Cleaning and Maintenance	119-111

■ Others

	Page
Troubleshooting	112-113
Product Specifications	114

General Preparation and Advice Before Use

■ Important Safety Information

This manual contains important information on safety, use and maintenance of the product. Please read the manual carefully and keep it in an easily accessible place for future reference.

■ Precautions before First Use

1. Two or more people are required to install or move this appliance as it is heavy. It must be securely placed on a firm and level surface. Failure to do so can cause physical injuries or damage to the appliance.
2. This appliance is designed solely for indoor and domestic use. Follow the cooking instructions indicated in the manual. Do not use this appliance for outdoor, commercial or any other purposes.
3. Check that the voltage on the rating label corresponds to the voltage in your home.
4. Ensure that the appliance is not damaged. Do not operate the appliance if it has a damaged mains cord or plug. If it is not working properly, or it has been damaged or dropped. Please contact Whirlpool Customer Services.
5. Do not immerse the power cord or plug in water. Keep the power cord away from hot surfaces to avoid electrical shock, fire or other accidents.
6. This steam microwave oven is designed for free standing installation. Do not install as a built-in appliance.
7. Allow adequate ventilation space on all sides and do not place any object on top. Keep a minimum distance of 5cm between the steam microwave oven and any overhead wall cabinet; and a minimum distance of 1cm between both sides of the appliance and the walls.
8. To avoid damage to the appliance, do not block the ventilation vent.
9. Run the "Steam mode" at 110°C for 30 minutes to clean and sterilize the combi steamer before first use.
10. The manufacturer disclaims all liability for faults arising from improper use of this appliance.
11. Steam is emitted from the top ventilation vent. Blocking the outlets will result in damage to the steam microwave oven.

12. Use heat resistant utensils for cooking, such as heat resistant glass and heat resistant plastic. Non-heat resistant containers should not be used with steam microwave oven. For steaming functions, container with heat resistant > 120°C should be used. For convection functions, container with heat resistant > 250°C should be used.

13. Odour will be emitted from the cavity when using different baking functions for the first time. It is normal.

■ Precautions and Advice

1. Stop using the steam microwave oven and contact Whirlpool Customer Service immediately if the door or door seal is damaged.
2. If the power cord is damaged, it must be replaced by the manufacturer, its service agent or similarly qualified persons in order to avoid a hazard.
3. To avoid fire hazard or explosion, do not heat or use flammable materials in or near the appliance.
4. To avoid fire hazard, do not use the appliance to dry cloth, paper, spices, herbs, wood, flowers or other flammable objects.
5. Overcooking food poses a fire hazard.
6. Never leave the appliance unattended during use, particularly when cooking with paper, plastic or other flammable materials. Paper may catch fire or get burned and some plastic materials may melt when heating up food with the appliance. If any object inside or outside the appliance is ignited or emits smoke, close the appliance door and switch off the combi steamer. Disconnect the power supply and the socket with circuit leakage breaker.
7. This steam microwave oven is specifically designed to heat or cook food. It is not designed for industrial or laboratory used.
8. This steam microwave oven is not intended for use by persons (including children) with reduced physical, sensory or mental capabilities, or lack of experience and knowledge, unless under supervision or instruction of a person responsible for their safety.
9. After cooking, clean the steam microwave oven only when it has completely cooled down. Wipe away any food debris or waste inside the oven. Top of the oven cavity gets burned easily and care should be taken to keep it clean. For best cooking results, keep the combi steamer completely dry by opening the door every time after cooking.

General Preparation and Advice Before Use

10. Use oven gloves to take food and containers out of the appliance to avoid burning.
11. To avoid a hazard, do not touch the upper heater in the oven when using the appliance.
12. Do not use the steam microwave oven for storage.
13. After heating food or beverages in nursing bottles or infant food cans, always stir and check the temperature before serving. This will ensure that heat is evenly distributed and the risk of scalding or burns can be avoided.
14. Wait 10-15 minutes after each program before continuing to another mode.
15. Steam will be rapid evaporated and not easily be seen if the oven cavity at the high temperature or just finished all convection modes. It is normal.
16. Do not touch the door and door frame when using the appliance.
17. Fill the water tank with tap water, drinking water or distilled water up to the MAX mark (maximum level). Insert the water tank into the appliance completely.
18. If the water tank is cracked or damaged, stop using it to avoid power leakage or electrical shock caused by water leakage.
19. For hygienic reasons and prevent condensation inside the combi steamer. Empty the water tank and keep the combi steamer completely dry every time after cooking.
18. If the water tank is cracked or damaged, stop using it to avoid power leakage or electrical shock caused by water leakage.
20. Do not fill the water tank with any liquids other than water (except descaler).
21. To avoid condensation and oven temperature drops, do not open the oven door when cooking with "Steam" mode unless it is absolutely necessary. If you have opened the oven door, extend the cooking time accordingly.
22. If it is necessary to open the oven door to turn the food or for other purposes during cooking, keep a distance from the oven door (particularly the face) to prevent scalding.
23. All maintenance and repairs should be carried out by similarly qualified person. It is dangerous to fix the appliance by anyone except similarly qualified person. Never dismantle, repair or modify the appliance by yourself.
24. Accessible parts of the appliance may become hot during use. Young children should be kept away.
25. When steam microwave oven is plugged, never touch the appliance, the power cord or plug with wet hands or other wet body parts.
26. Do not place or hang any objects on the oven door or the door handle. It may affect door's opening and closing or damage the door hinges.
27. After cooking ends, the electric fan will continue running for a certain period of time to cool down the cavity.
28. The steam microwave oven and its parts should be kept clean. Failure to do so will result in deterioration of the appliance surface and affect its life cycle. It may also cause danger.
29. Remove the power supply plug before cleaning. Do not use corrosive cleaners as they may cause damage or corrosion.
30. Water in the water tank will be heated up and discharged to the drip tray during "Descaling Mode". Do not allow children to touch or go near the combi steamer.
31. Clean dust from the power supply plug on a regular basis. If the product will not be used for a long time, remove the power supply cord. Do not pull the power supply cord but hold the plug to remove it.
32. Never leave the steam microwave oven in operation unattended.
33. Overheated fat and oil catch fire easily. Except grilling meat, heating oil during cooking is dangerous. Such practice should never be allowed.
34. Maximum load for the oven door is 7kg. To avoid damaging the steam microwave oven, do not place food or heavy objects on the oven door.

General Preparation and Advice Before Use

■ Mounting the Appliance

1. Good ventilation must be ensured around the steam microwave oven. Do not place any objects on top of the appliance and allow a minimum distance of 30 cm between the microwave steam oven and any overhead wall cabinet. Keep a minimum distance of 5 cm between both sides of the appliance and walls. Appliance back can be closed to the wall.

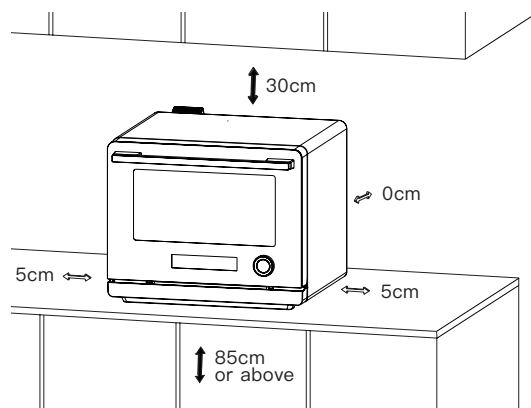

2. To prevent fire, do not block the air outlet and steam outlet. Maintain the product regularly and prevent foreign matter and dust from blocking the air outlet and steam outlet.
3. Do not put the appliance in a hot or humid place, such as gas stove, electrified areas or sink.
4. This appliance must be placed on a firm and stable surface.

■ Earthing Instructions

This appliance must be earthed. In case of electric leakage, the ground can provide a current loop to avoid electric shock. The power supply plug that comes with this appliance must be inserted into a single-phase-bipolar socket with grounding.

General Preparation and Advice Before Use

■ Appliance and Accessories Chart

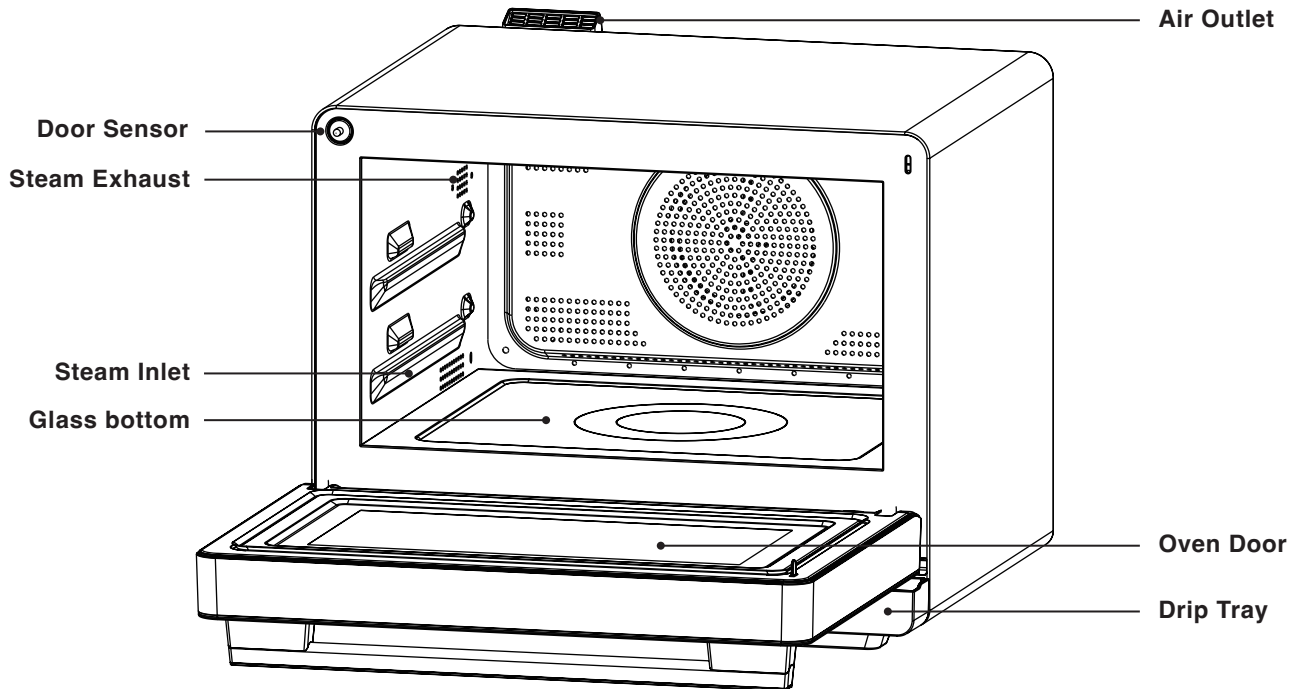

- **Air Outlet:** To exhaust excessive steam from the cavity
- **Steam Exhaust:** To discharge excess steam from the cavity
- **Steam Inlet:** To release steam into the cavity
- **Oven Door:**
 1. Make sure the door is closed before starting to cook.
 2. The microwave steam oven will pause if you open the oven door during cooking. The selected mode will continue automatically once the door is closed.
- **Drip Tray:** To collect excess water when the door is open.
- **Door Sensor:** To sense the door closed.
- **Glass bottom:** Place the container with food on the glass bottom directly when using microwave function to cook.

General Preparation and Advice Before Use

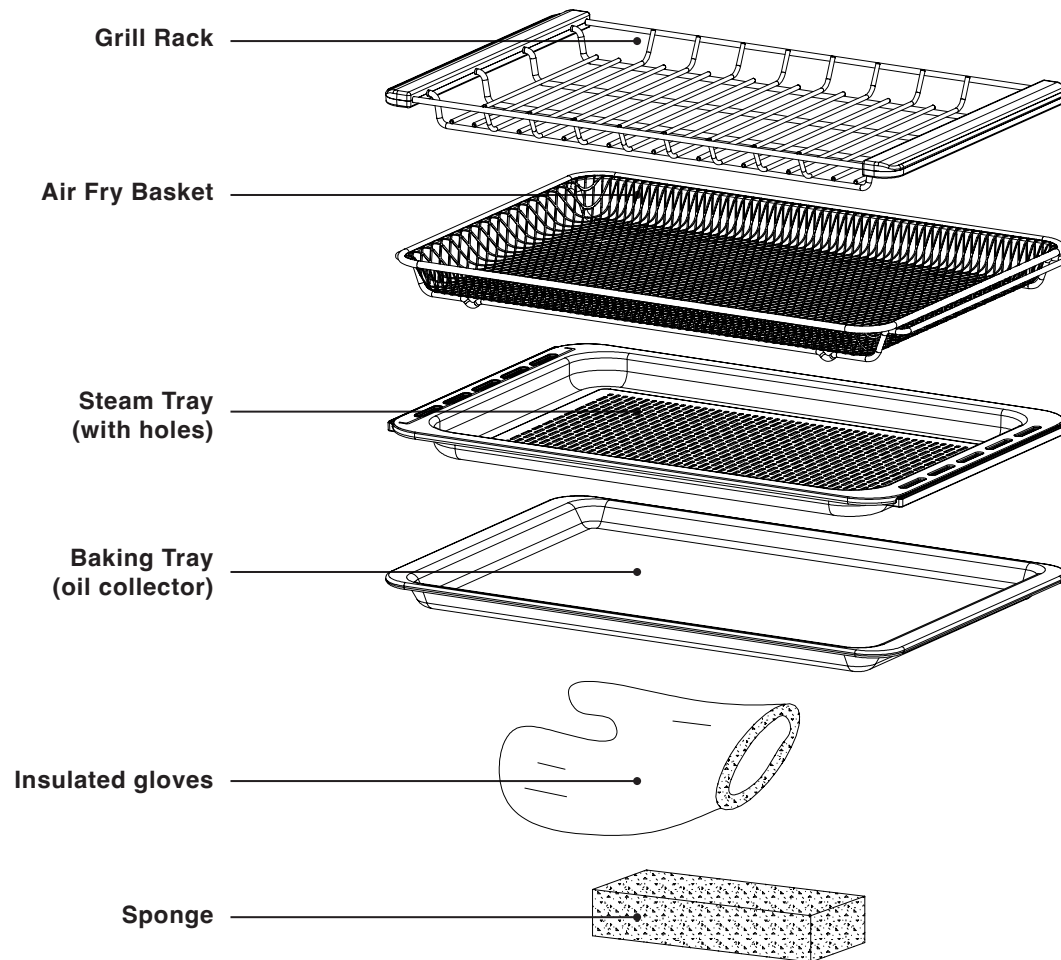

1. Grill Rack

Mainly for modes that cook with the heater, such as “Grill”, “Convection” or “Forced Air” modes.

2. Air Fry Basket

For use under “Air Fry” mode. Do not use it for cooking mode with microwave.

3. Steam Tray (with holes)

Mainly for the “Steam” mode. Designed with vent holes, it can also be used for other cooking modes.

4. Baking Tray (oil collector)

Mainly for the “Forced Air + Steam”, “Convection + Steam” or “Forced Air” mode. It can also be placed at the bottom level to collect dripping oil when cooking meat.

5. Insulated gloves

To take food or rack out from the microwave steam oven.

6. Sponge

To remove condensation inside the oven.

General Preparation and Advice Before Use

Water tank and drip tray

Water tank:
holds clean water
to produce steam

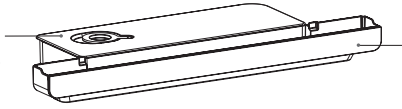

Drip tray: collect excess water
when the door is open.

Installation:
Removing / installation method

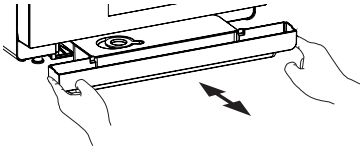

Water tank may contain remaining water, please be careful when taking it out.
When installing, make sure the water tank cover is closed tightly, push the water tank all the way in, and ensure the water tank is installed in place; Tilt may cause water to overflow, please keep it horizontal at all times.

How to fill water:

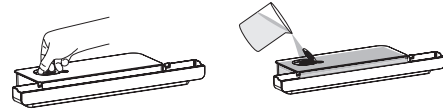

Before using steam cooking, please open the round silicone lid and pour clean water or distilled water until the water tank is full.

Notice!





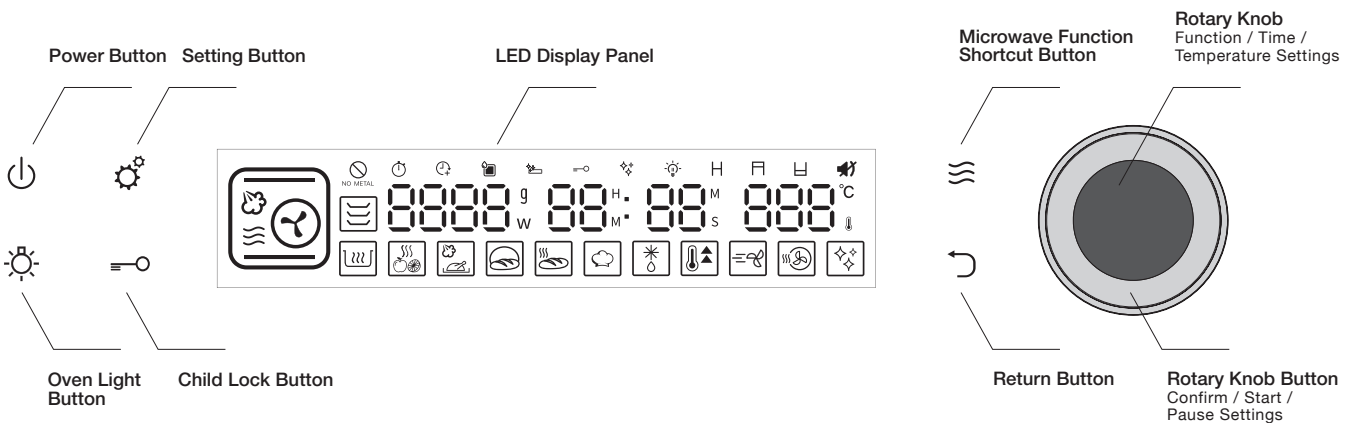

- For first time use or when you have not use steam function to cook for a long time, please clean by running the steam mode (110°C) before cooking;
- Please clean the water tank and drip tray from time to time;
- Please use pure water or distilled water for cooking, otherwise scale deposit may occur;
- When using steam function to cook, be sure to fill the water tank with water and ensure the water tank is properly installed. If there is too little water or the water tank is not installed properly, “please add water” icon will appear and prompt during steam cooking and cooking will be suspended.

Control Panel

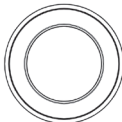

General Preparation and Advice Before Use

■ Control Panel – Basic Functions

Icon	Function Descriptions
	<p>Rotary Knob Function / Time / Temperature Settings</p> <p>Rotary Knob Button Confirm / Start / Pause Settings</p>
	<p>Setting/ Auto Menu Button</p> <ol style="list-style-type: none"> 1. Under Standby mode, press once to enter auto menu function and select recipe; 2. Under Standby mode, hold the setting button for 3 seconds to enter clock setting; 3. Under “DIY function”, press setting button to enter next cooking function setting; 4. While setting cooking time/ temperature, hold the setting button for 3 seconds to enter “Preset function” 5. When cooking in progress, hold the setting button for 3 seconds to check cavity actual temperature 6. In pause mode, press setting button to adjust cooking time and temperature
	<p>Return Button</p> <ol style="list-style-type: none"> 1. Return / Reset; 2. Press the return button during setting to go back to the previous screen or reset cooking modes or cooking time. 3. Mute Mode To activate mute mode: In standby mode, press and hold the button for 3 seconds to activate the mute mode. The mute icon lights up on the display panel. To release mute mode: In standby mode, press and hold the return button for 3 seconds while it is activated.
	<p>Oven Light Button</p> <ol style="list-style-type: none"> 1. Touch once to switch the light on for 3 minutes. The oven light icon will not light up on the display panel. 2. During cooking in process, press and hold for 3 seconds, the oven light will stay on. The oven light icon will light up on the display panel. Press and hold for 3 seconds again to switch off the oven light. 3. At standby mode, press and hold for 3 seconds, the oven light will stay on for 5 minutes. The oven light icon will light up on the display panel. If there is no operation in 5 minutes, the oven will switch to standby mode, oven light will be switched off automatically. 4. The oven light will light up for 3 minutes when the door is open.
	<p>Child Lock Button</p> <p>Press and hold the button for 3 seconds to activate / release the child lock.</p> <p>To activate child lock: Press and hold the button for 3 seconds. The control panel will be locked and no operation is possible. The child lock icon lights up on the display panel.</p> <p>To release child lock: To release, press and hold the child lock button for 3 seconds while it is activated.</p>
	<p>Power Button</p> <p>After 5 minutes without operation after activate the combi steamer, including opening or closing the oven door. Combi steamer will automatically enter to power-saving mode, display panel goes out. In power-saving mode, only power button is operable. To release child lock: To release, press and hold the child lock button for 3 seconds while it is activated.</p>
	<p>Microwave Shortcut Button</p> <ol style="list-style-type: none"> 1. Press the microwave shortcut button to enter microwave function setting under standby mode or other setting mode 2. Press and hold the microwave shortcut button for 3 seconds for Jet Start function (cook 30 seconds with full power microwave)

General Preparation and Advice Before Use



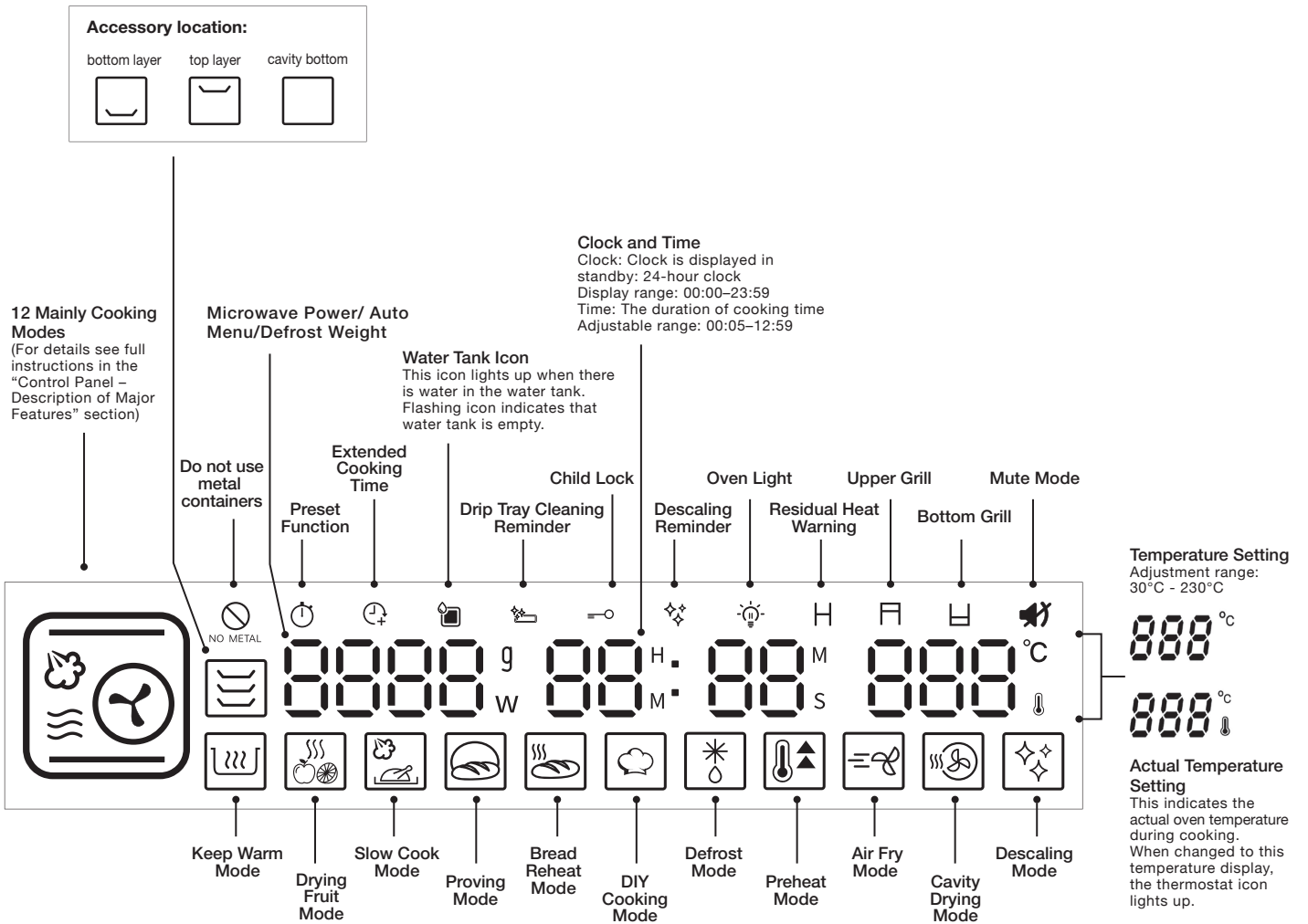







Control Panel – Major Features





General Preparation and Advice Before Use

■ Control Panel – Description of Major Features

Major Cooking Mode











Icon	Mode	Function Descriptions	Default Time/ Temperature	Time/ Temperature Selection Range
	Steam	Steam cooking preserves the original taste, nutrients and color of food cooked. It is suitable for steaming vegetables, meat and seafood or braising soup.	20 mins / 100°C	Time: 5-419 mins (maximum 6 hours 59 mins) Temperature: 50-110°C
	Steam + Microwave	Steam cooking preserves the original taste, nutrients and color of food cooked. Adding microwave to cooking process can shorten cooking time. It is suitable for long hour steaming food, such as, braising soup and meat.	15 mins / 100°C	Time: 5-419 mins (maximum 6 hours 59 mins) Temperature: 50-110°C
	Upper Grill	Suitable for roasting baking - food or at a final stage of roasting or baking. It helps browning the surface of your dish.	25 mins / 110°C	Time: 5-239 mins (maximum 3 hours 59 mins) Temperature: 50-230°C
	Upper Grill + Microwave	Suitable for roasting baking food, cooking time can be shorten with microwave.	20 mins / 100°C	Time: 5-239 mins (maximum 3 hours 59 mins) Temperature: 50-230°C
	Bottom Grill	Suitable for baking the final stage or for food that needs to be cooked from the bottom periodically during cooking. e.g. pizzas, macaroon.	20 mins / 100°C	Time: 5-239 mins (maximum 3 hours 59 mins) Temperature: 50-230°C
	Conventional Bake	Traditional single-level baking and grilling mode. Heat is released from the top and bottom to get food baked evenly. Suitable for cooking meat, fish, bread and cookies, pastries and desserts etc., and particularly suitable for cakes with moist ingredients at the top.	30 mins / 180°C	Time: 5-239 mins (maximum 3 hours 59 mins) Temperature: 50-230°C
	Conventional Bake + Microwave	Traditional single-level baking and grilling mode. Heat is released from the top and bottom to get food baked evenly and quickly with microwave. Suitable for cooking meat, bread, pastries and desserts etc.	25 mins / 180°C	Time: 5-239 mins (maximum 3 hours 59 mins) Temperature: 50-230°C
	Convection	The upper and bottom heater and rear fan operate simultaneously in this mode. Suitable for all baking dishes, such as meat, seafood, pizzas, bread and cookies, pastries and desserts.	20 mins / 160°C	Time: 5-239 mins (maximum 3 hours 59 mins) Temperature: 80-230°C
	Turbo Convection	Cooking time is shortened in this mode to bake and roast food quickly. It is suitable for baking large meat and cakes.	25 mins / 180°C	Time: 5-239 mins (maximum 3 hours 59 mins) Temperature: 80-230°C
	Turbo Convection + Microwave	With microwave support, cooking time can be shortened further in this mode to bake and roast food quickly. It is suitable for baking large meat.	15 mins / 120°C	Time: 5-239 mins (maximum 3 hours 59 mins) Temperature: 50-230°C

General Preparation and Advice Before Use

Icon	Mode	Function Descriptions	Default Time/ Temperature	Time/ Temperature Selection Range
	Convection + Steam	This mode combines upper, lower heat, hot air and steam cooking. It is a perfect all-in-one combination cooking. Adding steam during the cooking process can prevent moisture loss during high temperature cooking. Suitable for cooking all types of food, such as large cuts of meat or baking moist cakes.	20 mins / 180°C	Time: 5-419 mins (maximum 6 hours 59 mins) Temperature: 100-230°C
	Convection + Steam + Microwave	This mode combines upper, lower heat, hot air, steam and microwave cooking. It is a perfect all-in-one combination cooking. Adding steam during the cooking process can prevent moisture loss during high temperature cooking, while microwave can shorten the total cooking time. Especially suitable for cooking large portion of food, such as large cuts of meat.	15 mins / 180°C	Time: 5-239 mins (maximum 3 hours 59 mins) Temperature: 80-230°C
	Microwave	Microwaves can heat food quickly and are suitable for reheating food.	30 sec / 900W	10 sec - 90 mins 55 sec 100 W - 900 W

General Preparation and Advice Before Use

Cooking Functions

Icon	Mode	Function Descriptions	Default Time/ Temperature	Time/ Temperature Selection Range
	Keep Warm	Keeping food warm with hot air. Suitable for keeping cooked dishes warm.	20 minutes / 55°C	Time: 5-419 mins (maximum 6 hours 59 mins) Temperature: 50-110°C
	Drying Fruit	Food is dehydrated with hot air in low heat. Suitable for preparing dried fruit and sliced vegetable or meat jerkies.	20 mins / 60°C	Time: 5-779 mins (maximum 12 hours 59 mins) Temperature: 40-90°C
	Slow Cook	Steam is injected to maintain temperature inside the oven for slow cooking. Low temperature is used, meat and seafood can be preserved the original flavor without overcooking. Food can be placed in vacuum bags for this mode.	60 mins / 60°C	Time: 60-779 mins (maximum 12 hours 59 mins) Temperature: 50-90°C
	Proving	This mode works with steam to ensure stable and humidity inside the oven. It allows doughs (for pizzas or bread) to rise quicker in a stable environment, and it used for fermenting pizzas or bread.	40 mins / 35°C	Time: 5-779 mins (maximum 12 hours 59 mins) Temperature: 25-50°C
	Bread Reheat	Bread is reheated at a regulated temperature and steam is added to reheat bread that tastes just like freshly-baked. Two heating modes are available: Room temperature bread and refrigerated bread.	10 mins / 180°C	Time: 5-59 mins Temperature: Cannot be adjusted
	Defrost	Defrost chilled or frozen food.	7 mins 40 sec / 500g	100g - 2000g
	Preheat – Steam	Oven is heated to preset temperature by steam.	Present time / 100°C	Temperature: 50-110°C
	Preheat – Baking	Oven is heated to preset temperature by baking function.	Present time / 180°C	Temperature: 100-230°C
	Air Fry	A fan is used to circulate heat in the oven cavity to create convection, allowing the food to be baked in a shorter time to create a crispy effect. It is suitable for food that needs to be air-fried or for baking larger meats and pastries.	25 mins / 180°C	Time: 5-239 mins (maximum 3 hours 59 mins) Temperature: 80-230°C
	Cavity Drying	In this mode, the oven is heated to a high temperature so any excessive moisture and steam are evaporated. This function is used for drying the oven after any steam cooking modes.	15 mins / 180°C	Time: Cannot be adjusted Temperature: Cannot be adjusted
	Descaling	Descaling icon will be on once combi steamer has reached 100 hours steam related cooking time to remind the user to run descaling programme mode. A descaler is required.	60 mins	Time: Cannot be adjusted Temperature: Cannot be adjusted
	DIY Cooking	Complete a variety of different cooking function combination at one time automatically.		





























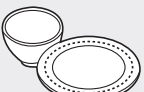

General Preparation and Advice Before Use

■ Use and Cooking Tips



1. Minimum time setting is 5 minutes for all cooking modes (Except the "Increase the Cooking Time after Cooking is Completed" function).
2. After cooking is done, the fan will continue to work for 3 minutes for cool down purpose. This is normal.
3. The combi steamer will pause automatically if you open the oven door during cooking. Cooking will continue automatically at the set time and temperature once the door is closed.
4. Take extra care when removing container from the oven after heating, like soup, sauce or beverage. To prevent over boiling, following steps should be taken in cooking liquid.
 - (a) Do not over-heat liquid food. Boiling liquid may splash out and cause scalding when you remove it from the combi steamer.
 - (b) When heating up liquid food, make sure the container is at most 80% full because a small amount of liquid may splash out suddenly when boiled.
 - (c) Stir the liquid before and during heating.
 - (d) Allow the food to stand inside the combi steamer for a while when heating is done. Stir it gently before removing.
 - (e) When using a feeding bottle or heating baby food, stir or shake the food and check the temperature before feeding to avoid burning.
5. Only use a thermometer designed for ovens to check food temperature during cooking, if necessary. If longer cooking time is required, put the food back into the combi steamer to continue cooking.
6. To avoid overheating or over-browning, it is recommended to take the food out when roasting or steaming is finished.
7. To maintain constant temperature during cooking, do not open the oven door unless it is necessary. To avoid affecting oven temperature, do not open the oven door to check food during cooking. If you have opened the oven door, extend the cooking time accordingly.
8. To ensure even browning and cooking, adjust or turn the food's position or direction of the steam or grill plate halfway during heating.

General Preparation and Advice Before Use

■ Recommended Recipes

Type of container	Microwave	Combi (with steam, microwave or grill)	Steam	Grill/ Convection
Heat-resistant glass container 	 When cooking food which will produce high temperatures, e.g. jam, please use super heat-resistant glass containers that are resistant to sudden cold and sudden heat.	 When cooking food which will produce high temperatures, e.g. jam, please use super heat-resistant glass containers that are resistant to sudden cold and sudden heat.		
Non heat-resistant glass container 	 Cut glass and tempered glass cannot be used either.	 Cut glass and tempered glass cannot be used either.		
Heat-resistant plastic container 	 Please use containers marked with "Suitable for Microwave". Note 1: Please note that some container lids have poor heat resistance. Note 2: It is prohibited to use lids with strong sealing properties. Note 3: Foods containing high amounts of oil and sugar are prone to high heat, so heat-resistant plastic containers cannot be used.	 Please use containers marked with "Suitable for Microwave". Note 1: Please note that some container lids have poor heat resistance. Note 2: It is prohibited to use lids with strong sealing properties. Note 3: Foods containing high amounts of oil and sugar are prone to high heat, so heat-resistant plastic containers cannot be used.		
Non heat-resistant plastic container 	 Containers made of materials (such as polyethylene, melamine, phenol, urea resin, etc.) are easily affected by microwaves and deteriorate, so containers made of these materials cannot be used.	 Containers made of materials (such as polyethylene, melamine, phenol, urea resin, etc.) are easily affected by microwaves and deteriorate, so containers made of these materials cannot be used.		
Ceramic and porcelain 	 Note: Containers decorated with gold, silver or color painting may cause color peeling, sparking, etc.	 Note: Containers decorated with gold, silver or color painting may cause color peeling, sparking, etc.		
Lacquerware 	 Paint may peel off or break.	 Paint may peel off or break.		

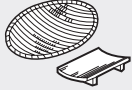
General Preparation and Advice Before Use

Type of container	Microwave	Combi (with steam, microwave or grill)	Steam	Grill/ Convection
Metal containers, such as aluminum 	X	X	✓	✓ Note: If the handle of a metal container is made of resin material, it cannot be used.
Wood / bamboo / paper containers 	X Prone to burning.	X Prone to burning.	X Note: Wooden, bamboo containers and thermal processed paper products can be used.	X Note: When the cooking temperature is 230 °C or below, paper containers with heat-resistant processing can be used.
Microwave cling film 	✓ It is recommended to use plastic wrap with a heat resistance of 140°C. Note: Cannot be used for cooking oily foods.	X	X	X Plastic wrap will melt when exposed to high temperatures.
Aluminum foil (household tin foil) 	X	X	✓	✓

When using the microwave function, you can use a microwave - safe container and place it directly on the cavity glass bottom for cooking.

- * It is prohibited to use metal utensils, otherwise sparks may be generated and cause malfunction.
- * Place the food directly in the center of the oven cavity. If there is more than one plate of food, please refer to the following placement method for optimal result (the food is concentrated in the center)

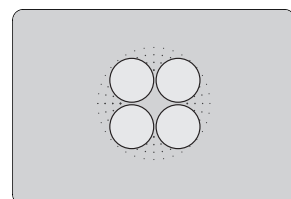
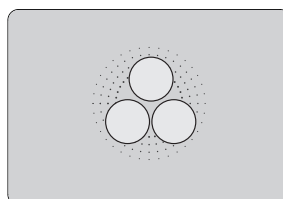
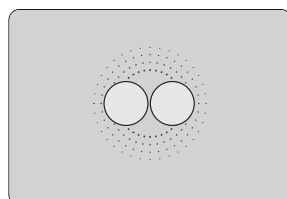
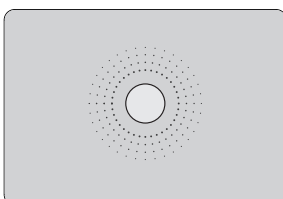

Operation Instructions

■ Setting the Clock

When the appliance is first powered on, it will beep and returned to standby mode. The default clock display is 12:00. The display panel lights up completely.



The steam microwave oven returned to energy saving mode if no button is pressed or door is opened for 5 minutes. Under energy saving mode, display will be turned off, only the power button can be used. Press the power button to exit the energy saving mode and back to the startup screen.

Example: Set the clock to the current time 13:20.

Steps:

1. On the standby screen, press and hold the setting button  for 3 seconds. The hour digits flash. (as shown in the diagram below)



2. Set the hour by turning the knob. When the hour reaches 13, press the knob to confirm. (as shown in the diagram below) The display will change to the minute setting automatically. The minute digits flash.



3. Set the minute by turning the knob. When the minute reaches 20, press the knob to confirm. (as shown in the diagram below)



4. Time setting is complete. (as shown in the diagram below)



Important: If no action is taken within 5 minutes during the setting process, all settings will be cancelled and the display will return to the standby screen. The steam microwave oven is in standby.

Operation Instructions

■ Microwave Mode



Baking Tray

Cavity Bottom

Suggested Accessory:

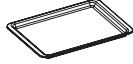

Accessories Location:





Microwaves can heat food quickly and are suitable for reheating food.

	Microwave Power	Time
Default Setting	900W	30 sec
Setting Range	100W - 900W	10 sec - 59 mins and 55 sec

 Attention! Do not use metal utensils (except our suggested accessory) to cook under this cooking function, otherwise sparks may be generated and cause malfunction.

Example: Set the cooking time to 2 minutes; microwave power is 900W.

Steps:

1. In standby mode, press  button on control panel or turn the knob to  microwave mode then press the knob to enter microwave function setting. Microwave Power will flash, turn the knob until display shows 900. Press the knob to confirm (as shown in the diagram below). The display will jump to minute setting automatically.



2. Turn the knob until the minute display shows 02. Press the knob to confirm (as shown in the diagram below). The display will jump to second setting automatically.



3. Press the knob to confirm 00 setting in second (as shown in the diagram below).



4. Setting is completed, microwave steam oven will start cooking.

Operation Instructions

■ Steam Mode



Steam Tray



Bottom Layer

Suggested Accessory:

Accessories Location:



Steam cooking preserves the original taste, nutrients and color of food. It is suitable for steaming vegetables, meat and seafood or braising soup. Always ensure the water tank is filled before using this mode.

	Temperature	Time
Default Setting	100°C	20 mins
Setting Range	50°C - 110°C	5 mins - 6 hours and 59 mins

Example: Set the cooking time to 1 hour and 40 minutes; cooking temperature is 110°C.

Steps:

1. In standby mode, turn the knob clockwise to  Steam Mode. The icon will flash. Press the knob to confirm (as shown in the diagram below). The display will jump to hour setting automatically.



2. Turn the knob until the hour display shows 01. Press the knob to confirm (as shown in the diagram below). The display will jump to minute setting automatically.



3. Turn the knob until the minute display shows 40. Press the knob to confirm (as shown in the diagram below). The display will jump to temperature setting automatically.



4. Turn the knob until the temperature display shows 90°C. Press the knob to confirm (as shown in the diagram below).



5. Setting is complete. The steam microwave oven will start cooking.

Operation Instructions

■ Steam + Microwave Mode



Grill Rack

Bottom Layer

Suggested Accessory:



Accessories Location:



Steam cooking preserves the original taste, nutrients and color of food. It is suitable for steaming vegetables, meat and seafood or braising soup. Always ensure the water tank is filled before using this mode.

	Temperature	Time
Default Setting	100°C	15 mins
Setting Range	50°C - 110°C	5 mins - 6 hours and 59 mins



NO METAL

Attention! Do not use metal utensils (except our suggested accessory) to cook under this cooking function, otherwise sparks may be generated and cause malfunction.

Example: Set the cooking time to 1 hour and 40 minutes; cooking temperature is 90°C.

Steps:

1. In standby mode, turn the knob clockwise to  Steam + Microwave Mode. The icon will flash. Press the knob to confirm (as shown in the diagram below). The display will jump to hour setting automatically.



2. Turn the knob until the hour display shows 01. Press the knob to confirm (as shown in the diagram below). The display will jump to minute setting automatically.



3. Turn the knob until the minute display shows 40. Press the knob to confirm (as shown in the diagram below). The display will jump to temperature setting automatically.



4. Turn the knob until the temperature display shows 90°C. Press the knob to confirm (as shown in the diagram below).



5. Setting is complete. The steam microwave oven will start cooking.

Operation Instructions

■ Upper Grill Mode

Grill Rack

Bottom Layer

Suggested Accessory:



Accessories Location:



Suitable for roasting baking - food or at a final stage of roasting or baking. It helps browning the surface of your dish.

	Temperature	Time
Default Setting	110°C	25 mins
Setting Range	50°C - 110°C	5 mins - 6 hours and 59 mins

Example: Set the cooking time to 40 minutes; temperature is 210°C.

Steps:

1. In standby mode, turn the knob clockwise to  Upper Grill mode. The icon will flash. Press the knob to confirm (as shown in the diagram below). The display will jump to hour setting automatically.



2. Press the knob to confirm 00 hour setting (as shown in the diagram below). The display will jump to minute setting automatically.



3. Turn the knob until the minute display shows 40. Press the knob to confirm (as shown in the diagram below). The display will jump to temperature setting automatically.



4. Turn the knob until temperature display shows 210°C. Press knob to confirm the upper grill temperature (as shown in the diagram below).



5. Setting is complete. The microwave steam oven will start cooking.

Operation Instructions

■ Upper Grill + Microwave Mode

Grill Rack

Bottom Layer

Suggested Accessory:



Accessories Location:



Suitable for roasting baking food, cooking time can be shorten with microwave.

	Temperature	Time
Default Setting	100°C	20 mins
Setting Range	50°C - 230°C	5 mins - 3 hours and 59 mins

 Attention! Do not use metal utensils (except our suggested accessory) to cook under this cooking function, otherwise sparks may be generated and cause malfunction.

Example: Set the cooking time to 40 minutes; temperature is 210°C.

Steps:

1. In standby mode, turn the knob clockwise to  Upper Grill + Microwave mode. The icon will flash. Press the knob to confirm (as shown in the diagram below). The display will jump to hour setting automatically.



2. Press the knob to confirm 00 hour setting (as shown in the diagram below). The display will jump to minute setting automatically.



3. Turn the knob until the minute display shows 40. Press the knob to confirm(as shown in the diagram below). The display will jump to temperature setting automatically.



4. Turn the knob until temperature display shows 210°C. Press knob to confirm the upper grill temperature (as shown in the diagram below).



5. Setting is complete. The microwave steam oven will start cooking.

Operation Instructions

■ Bottom Grill Mode

Grill Rack

Bottom Layer

Suggested Accessory:



Accessories Location:



Suitable for baking the final stage or for food that needs to be cooked from the bottom periodically during cooking, e.g. pizzas, macaroon.

	Temperature	Time
Default Setting	100°C	20 mins
Setting Range	50°C - 230°C	5 mins - 3 hours and 59 mins

Example: Set the cooking time to 40 minutes; temperature is 210°C.

Steps:

1. In standby mode, turn the knob clockwise to  Bottom Grill mode. The icon will flash. Press the knob to confirm (as shown in the diagram below). The display will jump to hour setting automatically.



2. Press the knob to confirm 00 hour setting (as shown in the diagram below). The display will jump to minute setting automatically.

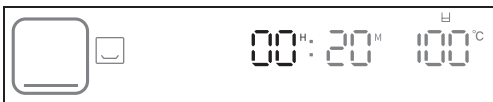

3. Turn the knob until the minute display shows 40. Press the knob to confirm (as shown in the diagram below). The display will jump to temperature setting automatically.



4. Turn the knob until temperature display shows 210°C. Press knob to confirm the bottom grill temperature (as shown in the diagram below).



5. Setting is complete. The microwave steam oven will start cooking.

Operation Instructions

■ Conventional Bake Mode

Grill Rack

Bottom Layer

Suggested Accessory:



Accessories Location:



	Temperature	Time
Default Setting	180°C	30 mins
Setting Range	50°C - 230°C	5 mins - 3 hours and 59 mins

Example: Set the cooking time to 40 minutes; upper grill temperature is 210°C, bottom grill temperature is 180°C.

Steps:

1. In standby mode, turn the knob clockwise to  Conventional Bake mode. The icon will flash. Press the knob to confirm (as shown in the diagram below). The display will jump to hour setting automatically.



2. Press the knob to confirm 00 hour setting (as shown in the diagram below). The display will jump to minute setting automatically.

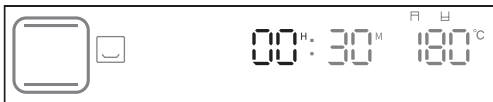

3. Turn the knob until the minute display shows 40. Press the knob to confirm(as shown in the diagram below). The display will jump to upper grill temperature setting automatically.



4. Turn the knob until temperature display shows 210°C. Press knob to confirm the bottom upper grill temperature (as shown in the diagram below). The display will jump to bottom grill temperature setting automatically.



5. Turn the knob until temperature display shows 180°C. Press knob to confirm the bottom grill temperature (as shown in the diagram below).



6. Setting is complete. The microwave steam oven will start cooking.

Operation Instructions

■ Conventional Bake + Microwave Mode

Grill Rack

Bottom Layer

Suggested Accessory:



Accessories Location:



Traditional single-level baking and grilling mode. Heat is released from the top and bottom to get food baked evenly and quickly with microwave. Suitable for cooking meat, bread, pastries and desserts etc.

	Temperature	Time
Default Setting	180°C	25 mins
Setting Range	50°C - 230°C	5 mins - 3 hours and 59 mins



Attention! Do not use metal utensils (except our suggested accessory) to cook under this cooking function, otherwise sparks may be generated and cause malfunction.

Example: Set the cooking time to 40 minutes; upper grill temperature is 180°C, bottom grill temperature is 160°C.

Steps:

1. In standby mode, turn the knob clockwise to  Conventional Bake + Microwave mode. The icon will flash. Press the knob to confirm (as shown in the diagram below). The display will jump to hour setting automatically.



2. Press the knob to confirm 00 hour setting (as shown in the diagram below). The display will jump to minute setting automatically.



3. Turn the knob until the minute display shows 40. Press the knob to confirm (as shown in the diagram below). The display will jump to upper grill temperature setting automatically.



4. Turn the knob until temperature display shows 160°C. Press knob to confirm the bottom grill temperature (as shown in the diagram below).



5. Setting is complete. The microwave steam oven will start cooking.

Operation Instructions

■ Convection Mode

Baking Tray

Bottom layer

Suggested Accessory:

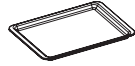

Accessories Location:



The upper and lower heaters and rear fan operate simultaneously in this mode. Suitable for all baking dishes, such as meat, seafood, pizzas, bread and cookies, pastries and desserts. It is recommended to place aluminium foil or baking paper onto the baking tray before cooking.

	Temperature	Time
Default Setting	160°C	20 mins
Setting Range	80°C - 230°C	5 mins - 3 hours and 59 mins

Example: Set the cooking time to 40 minutes; cooking temperature is 210°C.

Steps:

1. In standby mode, turn the knob clockwise to  Convection Mode. The icon will flash. Press the knob to confirm (as shown in the diagram below). The display will jump to hour setting automatically.



2. Press the knob to confirm the 00 hour setting (as shown in the diagram below). The display will jump to minute setting automatically.



3. Turn the knob until the minute display shows 40. Press the knob to confirm (as shown in the diagram below). The display will jump to temperature setting automatically.



4. Turn the knob until the temperature display shows 210°C. Press the knob to confirm (as shown in the diagram below).





5. Setting is complete. The combi steamer will start cooking.



Operation Instructions

■ Turbo Convection Mode

Suggested Accessory: 

Accessories Location: 

Cooking time is shortened in this mode to bake and roast food quickly. It is suitable for baking large meat and cakes. It is recommended to place aluminum foil or baking paper onto the baking tray before cooking.

	Temperature	Time
Default Setting	180°C	25 mins
Setting Range	80°C - 230°C	5 mins - 3 hours and 59 mins

Example: Set the cooking time to 40 minutes; cooking temperature is 210°C.

Steps:

1. In standby mode, turn the knob clockwise to  Turbo Convection Mode. The icon will flash. Press the knob to confirm (as shown in the diagram below). The display will jump to hour setting automatically.



2. Press the knob to confirm the 00 hour setting. (as shown in the diagram below). The display will jump to minute setting automatically.



3. Turn the knob until the minute display shows 40. Press the knob to confirm (as shown in the diagram below). The display will jump to temperature setting automatically.



4. Turn the knob until the temperature display shows 210°C. Press the knob to confirm (as shown in the diagram below).



5. Setting is complete. The combi steamer will start cooking.

Operation Instructions

■ Turbo Convection + Microwave Mode



Baking Tray

Bottom layer

Suggested Accessory:

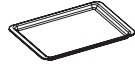

Accessories Location:



Traditional single-level baking and grilling mode. Heat is released from the top and bottom to get food baked evenly and quickly with microwave. Suitable for cooking meat, bread, pastries and desserts etc.

	Temperature	Time
Default Setting	180°C	15 mins
Setting Range	50°C - 230°C	5 mins - 3 hours and 59 mins



NO METAL

Attention! Do not use metal utensils (except our suggested accessory) to cook under this cooking function, otherwise sparks may be generated and cause malfunction.

Example: Set the cooking time to 40 minutes; cooking temperature is 210°C.

Steps:

1. In standby mode, turn the knob clockwise to  Turbo Convection + Microwave Mode. The icon will flash. Press the knob to confirm (as shown in the diagram below). The display will jump to hour setting automatically.



2. Press the knob to confirm the 00 hour setting. (as shown in the diagram below). The display will jump to minute setting automatically.

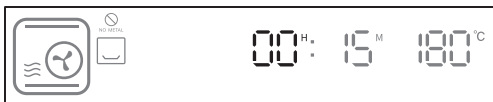

3. Turn the knob until the minute display shows 40. Press the knob to confirm (as shown in the diagram below). The display will jump to temperature setting automatically.



4. Turn the knob until the temperature display shows 210°C. Press the knob to confirm (as shown in the diagram below).



5. Setting is complete. The steam microwave oven will start cooking.

Operation Instructions

■ Convection + Steam Mode



Baking Tray

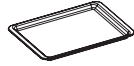

Bottom layer



Suggested Accessory:

Accessories Location:

This mode combines upper, lower heat, hot air and steam cooking. It is a perfect all-in-one combination cooking. Adding steam during the cooking process can prevent moisture loss during high temperature cooking. Suitable for cooking all types of food, such as large cuts of meat or baking moist cakes.

	Temperature	Time
Default Setting	180°C	20 mins
Setting Range	80°C - 230°C	5 mins - 3 hours and 59 mins

Example: Set the cooking time to 40 minutes; cooking temperature is 210°C.

Steps:

1. In standby mode, turn the knob clockwise to  Convection + Steam Mode. The icon will flash. Press the knob to confirm (as shown in the diagram below). The display will jump to hour setting automatically.



2. Press the knob to confirm the 00 hour setting (as shown in the diagram below). The display will jump to minute setting automatically.



3. Turn the knob until the minute display shows 40. Press the knob to confirm (as shown in the diagram below). The display will jump to temperature setting automatically.



4. Turn the knob until the temperature display shows 210°C. Press the knob to confirm (as shown in the diagram below).



5. Setting is complete. The combi steamer will start cooking.

Operation Instructions

■ Convection + Steam + Microwave Mode

Suggested Accessory: 

Accessories Location: 

This mode combines upper, lower heat, hot air, steam and microwave cooking. It is a perfect all-in-one combination cooking. Adding steam during the cooking process can prevent moisture loss during high temperature cooking, while microwave can shorten the total cooking time. Especially suitable for cooking large portion of food, such as large cuts of meat.

	Temperature	Time
Default Setting	180°C	15 mins
Setting Range	80°C - 230°C	5 mins - 3 hours and 59 mins

 **Attention!** Do not use metal utensils (except our suggested accessory) to cook under this cooking function, otherwise sparks may be generated and cause malfunction.

Example: Set the cooking time to 40 minutes; cooking temperature is 210°C.

Steps:

- In standby mode, turn the knob clockwise to  Convection + Steam + Microwave mode. The icon will flash. Press the knob to confirm (as shown in the diagram below). The display will jump to hour setting automatically.



- Press the knob to confirm 00 hour setting (as shown in the diagram below). The display will jump to minute setting automatically.



- Turn the knob until the minute display shows 40. Press the knob to confirm (as shown in the diagram below). The display will jump to temperature setting automatically.



- Turn the knob until temperature display shows 210°C. Press knob to confirm the bottom grill temperature (as shown in the diagram below).



- Setting is complete. The microwave steam oven will start cooking.

Operation Instructions

■ Keep Warm Mode

Baking Tray

Bottom layer

Suggested Accessory:

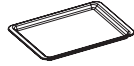

Accessories Location:



Keeping food warm with hot air. Suitable for keeping cooked dishes warm.

	Temperature	Time
Default Setting	55°C	20 mins
Setting Range	50°C - 110°C	5 mins - 6 hours and 59 mins

Example: Set the cooking time to 1 hours and 30 minutes; cooking temperature is 60°C.

Steps:

1. In standby mode, turn the knob clockwise to  Keep Warm Mode. The icon will flash. Press the knob to confirm (as shown in the diagram below). The display will jump to hour setting automatically.



2. Turn the knob until the hour display shows 01. Press the knob to confirm (as shown in the diagram below). The display will jump to minute setting automatically.

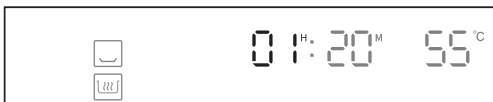

3. Press the knob to confirm the “30” minute setting (as shown in the diagram below). The display will jump to temperature setting automatically.



4. Turn the knob until the temperature display shows 60°C. Press the knob to confirm (as shown in the diagram below).



5. Setting is complete. The steam microwave oven will start cooking.

Operation Instructions

■ Drying Fruit Mode



Baking Tray

Bottom layer

Suggested Accessory:



Accessories Location:



Food is dehydrated with hot air in low heat. Suitable for preparing dried fruit and vegetable slices or meat jerkies.

	Temperature	Time
Default Setting	60°C	20 mins
Setting Range	40°C - 90°C	5 mins - 12 hours and 59 mins

Example: Set the cooking time to 2 hours; cooking temperature is 60°C.

Steps:

1. In standby mode, turn the knob clockwise to  Drying Fruit Mode. The icon will flash. Press the knob to confirm (as shown in the diagram below). The display will jump to hour setting automatically.



2. Turn the knob until the hour display shows 02. Press the knob to confirm (as shown in the diagram below). The display will jump to minute setting automatically.

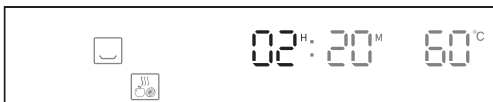

3. Press the knob to confirm the 00 minute setting (as shown in the diagram below). The display will jump to temperature setting automatically.



4. Turn the knob until the temperature display shows 90°C. Press the knob to confirm (as shown in the diagram below).



5. Setting is complete. The steam microwave oven will start cooking.

Operation Instructions

■ Slow Cook Mode



Baking Tray



Bottom layer



Suggested Accessory:

Accessories Location:

Steam is injected to maintain temperature inside the oven for slow cooking. Low temperature is used, meat and seafood can be preserved the original flavor without overcooking. Food can be placed in vacuum bags. Always ensure that the water tank is filled before using this mode.

	Temperature	Time
Default Setting	60°C	60 mins
Setting Range	50°C - 90°C	60 mins - 12 hours and 59 mins

Example: Set the cooking time to 40 minutes; cooking temperature is 60°C.

Steps:

1. In standby mode, turn the knob clockwise to Slow Cook Mode. The icon will flash. Press the knob to confirm (as shown in the diagram below). The display will jump to hour setting automatically.



2. Press knob to confirm hour 01 (as shown in the diagram below). The display will jump to minute setting automatically.



3. Turn the knob until the minute display shows 40. Press the knob to confirm (as shown in the diagram below). The display will jump to temperature setting automatically.



4. Press the knob to confirm 60°C temperature setting. (as shown in the diagram below).



5. Setting is complete. The steam microwave ovenr will start cooking.

Operation Instructions

■ Proving Mode

Steam Tray

Bottom layer

Suggested Accessory:



Accessories Location:



This mode works with steam to ensure stable high temperature and humidity inside the oven. It allows dough (for pizza or bread) to rise quicker in a stable environment, and is used for fermenting dough for pizzas or bread. Always ensure that the water tank is filled before using this mode.

	Temperature	Time
Default Setting	35°C	40 mins
Setting Range	25°C - 50°C	5 mins - 12 hours and 59 mins

Example: Set the cooking time to 40 minutes; cooking temperature is 35°C.

Steps:

1. In standby mode, turn the knob clockwise to  Proving Mode. The icon will flash. Press the knob to confirm (as shown in the diagram below). The display will jump to hour setting automatically.



2. Press the knob to confirm the 00 hour setting (as shown in the diagram below). The display will jump to minute setting automatically.



3. Turn the knob until the minute display shows 40. Press the knob to confirm (as shown in the diagram below). The display will jump to temperature setting automatically.



4. Turn the knob to confirm the 35°C temperature setting (as shown in the diagram below).



5. Setting is complete. The steam microwave oven will start cooking.

Operation Instructions

■ Bread Reheat Mode



Baking Tray

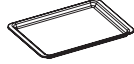

Bottom Layer

Suggested Accessory:

Accessories Location:



Bread is reheated at a regulated temperature and steam is added to reheat bread that tastes just like freshly-baked. Two heating modes are available: Room temperature bread and refrigerated bread. Always ensure that the water tank is filled before using this mode.

Suggested cooking time: Reheating time for frozen bread: about 10-15 minutes; Reheating time for room temperature bread: about 8-13 minutes. It is recommended to add 5-10 minutes for bread with fillings. This suggested cooking time is solely for reference. Cooking time is affected by the bread's quantity, size, type and personal taste.

	Temperature	Time
Default Setting	180°C	10 mins
Setting Range	fixed	5 mins - 59 mins

Example: Cooking bread that has been refrigerated. Set the cooking time to 25 minutes

Steps:

1. In standby mode, turn the knob clockwise to  Bread Reheat Mode. The icon will flash. Press the knob to confirm (as shown in the diagram below). The display will jump to minute setting automatically.



2. Turn the knob until the minute display shows 25. Press the knob to confirm (as shown in the diagram below).



3. Setting is complete.

Operation Instructions

■ Defrost Mode



Baking Tray

Bottom Layer

Suggested Accessory:

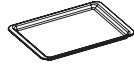

Accessories Location:



Defrost chilled or frozen food with Microwave.

	Food Weight	Time
Default Setting	500g	7 mins 40 sec
Setting Range	100g - 2000g	Automatically adjusted based on entered food weight



NO METAL

Attention! Do not use metal utensils (except our suggested accessory) to cook under this cooking function, otherwise sparks may be generated and cause malfunction.

Example: Defrost 600g food

Steps:

1. In standby mode, turn the knob anti-clockwise to Defrost mode. The icon will flash. Press the knob to confirm (as shown in the diagram below). The display will jump to hour setting automatically.



2. Turn the knob until the weight value display shows 600. Press the knob to confirm (as shown in the diagram below).



3. Setting is complete. The microwave steam oven will start cooking.

Operation Instructions

■ Preheat Mode

The Preheat Mode can be operated with steam or baking mode. The oven will be heated to preset temperature.

	Steam Preheating	Baking Preheating
	Temperature	Temperature
Default Setting	100°C	180°C
Setting Range	50°C - 110°C	100°C - 230°C

Oven will automatically adjust the cooking time according to set temperature. "END" will be displayed and an audio tone will be heard when the temperature reaches the preset temperature. Current time is displayed during preheating. Always ensure that the water tank is filled before using steam preheating.

Example: Set the steam preheating temperature to 80°C.

Steps:

1. In standby mode, turn the knob clockwise to  Preheat Mode. The icon will flash. Steam is the default setting. Press the knob to confirm (as shown in the diagram below).



2. The display will jump to temperature setting automatically. Turn the knob until temperature display shows 100°C. Press knob to confirm the bottom grill temperature (as shown in the diagram below).



3. Setting is complete. The steam microwave oven will start preheating.

Operation Instructions

Example: Set the baking preheating temperature to 200°C.

Steps:

1. In standby mode, turn the knob clockwise to Preheating Mode. The icon will flash. Steam is the default setting. Turn the knob to select the baking preheating mode, and then press the knob to confirm (as shown in the diagram below).



2. The display will jump to temperature setting automatically. Turn the knob until the display shows 200°C. Press the knob to confirm (as shown in the diagram below).



3. Setting is complete. The steam microwave oven will start preheating.

When preheating is complete, the display will show “END” and an audio tone will be heard. After preheating the combi steamer, you can select other cooking modes to continue your cooking as required.

Important: The function of “Adjust or Increase the Cooking Time during/after Cooking is Completed” is not available in this mode.

Operation Instructions

■ Air frying Mode



Air Fry Basket

Bottom Layer

Suggested Accessory:



Accessories Location:



A fan is used to circulate heat in the oven cavity to create convection, allowing the food to be baked in a shorter time to create a crispy effect. It is suitable for food that needs to be air-fried or for baking larger meats and pastries.

	Temperature	Time
Default Setting	180°C	25 mins
Setting Range	80°C - 230°C	5 mins - 3 hours and 59 mins

Example: Set the cooking time to 30 minutes; temperature is 210°C

Steps:

1. In standby mode, turn the knob anti-clockwise to  Air Fry mode. The icon will flash. Press the knob to confirm (as shown in the diagram below). The display will jump to hour setting automatically.



2. Press the knob to confirm 00 hour setting (as shown in the diagram below). The display will jump to minute setting automatically.

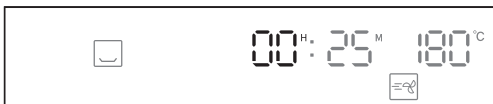

3. Turn the knob until the minute display shows 30. Press the knob to confirm (as shown in the diagram below). The display will jump to temperature setting automatically.



4. Turn the knob until temperature display shows 210°C. Press knob to confirm the temperature (as shown in the diagram below).



5. Setting is complete. The microwave steam oven will start cooking.

Operation Instructions

■ Cavity Drying Mode

In this mode, the oven is heated to a high temperature so any excessive moisture and steam are evaporated. This function is used for drying the oven after any steam cooking modes.

	Temperature	Time
Default Setting	180°C	15 mins
Setting Range	Cannot be adjusted	Cannot be adjusted

Steps:

1. In standby mode, turn the knob anti-clockwise to  Cavity Drying Mode. The icon will flash. (as shown in the diagram below).



2. Press the knob to confirm. The steam microwave oven will start cooking (as shown in the diagram below).





Operation Instructions

■ Descaling Mode



Water used in steaming mode may result in scale accumulated inside cavity and water pipe.

“Descaling” icon  will be on once combi steamer has reached 100hrs steam related cooking time to remind the user to run the descaling programme mode. The light will stay on until the descaling is performed.

Descaling is carried out in three stages that involve one descaling process and two descaling and cleaning processes. The user has to change the liquid in the tank 3 times during the entire cleaning process. It is also necessary to empty the drip tray by cleaning up. Icon  will be lighted to remind cleaning up the drip tray is needed.

Also, descaler is required for this mode. Customer can select the Wpro descaler under Whirlpool brand. This product can be used in steamer for cleaning limescale deposits effectively, optimizing machine performance and prolonging the lifespan of the appliance. For more details, please visit our website: www.whirlpool.com.hk

For satisfactory results, follow the suggested dosage for descaler and water below:

Stage 1: Descaling. Running time is 56 minutes. Suggested dosage: 30ml descaling agent and 300ml pure water.

Stage 2: Descaling and cleaning process. Running time is 4 minutes. Suggested dosage: 300ml pure water.

	Temperature	Time
Default Setting	Cannot be adjusted	60 mins
Setting Range	Cannot be adjusted	Cannot be adjusted

Steps:

1. Stage 1: Descaling

A. Add 30ml descaler and 300ml water into water tank.

B. In standby mode, turn the knob anti-clockwise to  Descaling Mode. The icon will flash. Press the knob to confirm (as shown in the diagram below).



C. The descaling mode will start (as shown in the diagram below).



D. Stage 1 takes 56 minutes. When done, the time display digits will flash and an audio tone will sound to indicate stage 1 is complete.  Drip tray cleaning reminder icon will light up on the display panel to remind the user to empty the drip tray.



E. Pour out the dirty liquid and put the drip tray back into place.

2. Stage 2: Descaling and cleaning process

- A. Open the oven door, add 300ml clean water into water tank.
- B. Put the water tank back into place and close the oven door. Press knob to confirm and resume descaling and cleaning process.



- C. When done, the time display digits will flash and an audio tone will sound to indicate descaling is complete.  Drip tray cleaning reminder icon will light up on the display panel to remind the user to empty the drip tray.



- D. Pour out the dirty liquid and put the drip tray back into place.

3. Descaling process is completed

Important:

1. The function of “Combination Button: Cavity temperature display” is not available in this mode.
2. The function of “Adjust or Increase the Cooking Time during/after Cooking is Completed” is not available in this mode.
3. Descaling mode will be interrupted if the steps of descaling mode is taken in the wrong way (including pause during the descaling process or open and close the oven door not following instructions etc). Please restart descaling mode and follow the instructions in the manual.

Operation Instructions

■ DIY Cooking Mode

It is used to complete a variety of different cooking function combination at one time automatically, make cooking more diverse and convenient.

For example, first cook with Steam Mode at 110°C for 1 hour 20 minutes, then cook with Turbo Convection + Microwave mode at 190°C for 1 hour 30 minutes, and then cook for 1 hour 30 minutes at 190°C with Turbo Convection mode.

Steps:

1. In standby mode, turn knob to  DIY Cooking mode. The icon will flash. Press to confirm the function. (As shown in the diagram below). The display will jump to cooking mode setting automatically.



2. Turn knob to  Steam mode. The icon will flash. Press knob to confirm cooking mode (as shown in the diagram below). The display will jump to hour setting automatically.

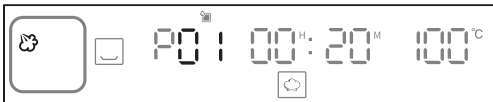

3. Turn knob until the hour display shows 01. Press knob to confirm (as shown in the diagram below). The display will jump to minute setting automatically.



4. Turn knob until the minute display shows 20. Press knob to confirm (as shown in the diagram below). The display will jump to temperature setting automatically.



5. Turn knob until the temperature display shows 110°C. Press  to confirm the 1st cooking function setting and jump to next cooking function setup. (as shown in the diagram below).



6. Turn knob to  Turbo Convection + Microwave mode. The icon will flash. Press knob to confirm cooking mode (as shown in the diagram below). The display will jump to hour setting automatically.



Operation Instructions

7. Turn knob until the hour display shows 01. Press knob to confirm (as shown in the diagram below). The display will jump to minute setting automatically.



8. Turn knob until the minute display shows 30. Press knob to confirm (as shown in the diagram below). The display will jump to temperature setting automatically.



9. Turn knob until the temperature display shows 190°C. Press  to confirm the 2nd cooking function setting and jump to next cooking function setup. (as shown in the diagram below).



10. Turn knob to  Turbo Convection mode. The icon will flash. Press knob to confirm cooking mode (as shown in the diagram below). The display will jump to hour setting automatically.



11. Turn knob until the hour display shows 01. Press knob to confirm (as shown in the diagram below). The display will jump to minute setting automatically.



12. Turn knob until the minute display shows 30. Press knob to confirm (as shown in the diagram below). The display will jump to temperature setting automatically.



13. Turn knob until the temperature display shows 190°C. Press  to confirm the 3rd cooking function setting



14. Setting is completed. The microwave steam oven will start cooking.

Operation Instructions

■ Adjust or Increase the Cooking Time during/after Cooking is Completed



A. Adjust the cooking time during cooking process

You can extend or shorten the cooking time and the temperature as required during the cooking process.
Example: Change the cooking time and temperature settings from 01:40 and 90°C to 02:00 and 100°C.

Steps:

1. During cooking, press the knob to interrupt and pause the cooking. The time display will flash (as shown in the diagram below).



2. Press the setting button . The display will go to the reset cooking time screen automatically. The hour digit flashes, and the  "Extended Cooking Time" icon lights up on the display (as shown in the diagram below).



3. Turn the knob until the hour display shows 02. Press the setting button  to confirm (as shown in the diagram below). The display will jump to minute setting automatically.



4. Turn the knob until the minute display shows 00. Press the setting button  to confirm (as shown in the diagram below). The display will jump to temperature setting automatically.



5. Turn the knob until the temperature display shows 100°C. Press the knob to confirm (as shown in the diagram below).



6. Setting is complete. Cooking will be resumed with new settings.

Operation Instructions

B. Increase the cooking time after cooking is completed

You can increase the cooking time after cooking is completed. Temperature cannot be adjusted.

	Temperature	Time
Setting Range	Cannot be adjusted	1 min to 59 mins

When cooking is completed, the “END” Will be shown on display and an audio tone sounds. The  “Extended Cooking Time” icon will light up on the display (As shown in the diagram below).

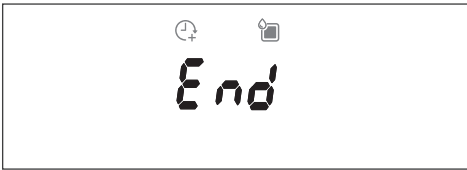

To increase the cooking time, follow the steps below:

Example: Cooking is completed and need to increase the cooking time by 3 minutes.

Steps:

1. Press the knob to confirm to increase the cooking time, the display will jump to minute setting automatically.



2. Turn the knob until the minute display shows 03. Press the knob to confirm (as shown in the diagram below).



3. Setting is complete. Cooking will resume with added cooking time under previous settings (as shown in the diagram below).



Note: If no action is taken within 5 minutes after cooking is completed, the combi steamer will return to standby mode.

Operation Instructions

■ Preset Function

You must set the clock before using the preset function. For instructions on clock setting, please see “Setting the Clock” on page 73 of this instruction manual.

Example: The current time is 12:00. You want to preset cooking time for the Bottom Grill Mode. Cooking time is 1 hour and 30 minutes and temperature is 90°C. Cooking will stop at 14:00.

Steps:

1. In standby mode, turn the knob clockwise  Bottom Grill Mode. The icon will flash. Press the knob to confirm (as shown in the diagram below). The display will jump to hour setting automatically.



2. Press the knob to confirm the 01 hour setting (as shown in the diagram below). The display will jump to minute setting automatically.



3. Turn the knob until the minute display shows 30. Press the knob to confirm (as shown in the diagram below). The display will jump to temperature setting automatically.



4. Turn the knob until the temperature display shows 90°C. Press the setting button for 3 seconds  to confirm (as shown in the diagram below).



5. Turn the knob until the hour display shows 14. Press the knob to confirm (as shown in the diagram below). The display will jump to minute setting automatically.

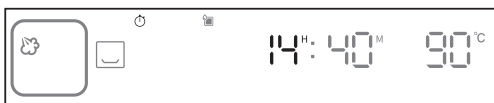

6. Turn the knob until the minute display shows 40. Press the knob to confirm. (as shown in the diagram below).





7. The  preset function icon of the display panel will flash. Display will change from operating time back to the current time 16:30, indicating preset setting is complete (as shown in the diagram below).



Operation Instructions

A. Checking Preset Function Status

Press and hold the setting button  for 3 seconds to check the preset stop time. The preset function icon will flash. Press and hold the setting button  for 3 seconds again to return to the preset function screen.

B. Cancelling Preset Function:

To cancel any preset function setting, press the  power button directly. The combi steamer will return to the standby screen automatically.

Important: Preset Function is available in 12 Mainly Cooking Modes, Bread Reheat Mode, Slow Cook Mode and Drying Fruit Mode. (See “Control Panel – Major Features/ Description of Major Features on P.65-69 for details) Suggestion: Preset cooking operation may be cancelled if children touch the screen accidentally. To avoid this, activate the child lock function after setting the preset function. For instructions on setting the child lock, please see “Control Panel – Basic Functions” on page 65 of this instruction manual. The child lock will not affect cooking. The steam microwave oven will start cooking normally at the preset time.

Operation Instructions

■ Auto Menu

In Standby mode, press  setting button to enter into Auto Menu to select recipe (P01 to P21), press knob to confirm the recipe.



Recipe no.	Dish	Recipe	Accessory location
P01	Steam Seabass	500g sea bass, 6 slices ginger, 6 green onions, 20ml soy sauce, 50ml oil 1. After cleaning the seabass, marinate it with oil and black pepper for half an hour; 2. Place ginger and green onion at the bottom of the dish, and put the seabass onto the dish; 3. Place in the top layer of the microwave steam oven and select P01; 4. After taking it out of the oven, pour out the sauce on the plate, add in soy sauce and hot oil.	top layer
P02	Baby Cabbage with Garlic	400g baby cabbage, garlic, 30ml soy sauce, 1 teaspoon salt, 70g oil, 10g oyster sauce 1. Cut the baby cabbage in half then cut each into 6 small pieces, and lay them flat on a plate; 2. Chop the garlic into minced garlic, add seasonings, pour hot oil to make garlic sauce; 3. Pour the sauce over the baby cabbage; 4. Place in top layer of the of the microwave steam oven and select P02.	top layer
P03	White clam steamed egg	2 eggs, 200ml room temperature water, 16 pieces white clam, ginger slices, rice wine, salt, soy sauce, Appropriate amount of oil. 1. Soak the white clams in salt water, add appropriate amount of oil, and soak for 1 hour; 2. Heat hot water in a pot, add ginger slices and rice wine, pour in the white clams, when shells slightly open take them all out from the water; 3. Add an appropriate amount of salt to the eggs and stir evenly, then pour in room temperature water and stir again evenly; 4. Place the white clams in the bottom of a shallow dish, with the opening facing up, and pour in the egg liquid; 5. Put in the top layer of microwave steam oven and select P03; 6. Take it out of the oven and sprinkle with chopped spring onion, pour soy sauce and hot oil.	top layer
P04	Steam Rice	50g rice, 370ml water 1. Wash the rice, pour it into a baking pan, and pour in water; 2. Place in the top layer of the microwave steam oven and select P04;	top layer
P05	Crispy Pork	700g pork belly, 2 tbsp salt, 2 tbsp five-spice powder, 1 tbsp white vinegar, 1 tbsp baking soda 1. Use a fire lance to burn the pork hair on the pork belly skin, and scrape with a knife to clean it; 2. Make a deep groove on the meat surface and sprinkle with five-spice powder and salt on all sides, except the pork skin, evenly. 3. Place the pork in a pot with cold water, cook until foam forms, take out the pork and clean with cold water; 4. Clean the pig skin, use a small sharp knife to poke holes, and penetrate the skin layer densely; 5. Pour an appropriate amount of white vinegar into the bottom of the plate and soak the pork skin side down for 5 minutes; 6. Pork skin side up, wrap the other sides with tin foil, and put it in the refrigerator overnight until the surface of the pig skin is dry; 7. Place in the top layer of microwave steam oven and select P05.	top layer

Others

Recipe no.	Dish	Recipe	Accessory location
P06	Honey Chicken Wings	<p>12 pieces chicken wing, 70g marinated chicken wing powder, 20g minced garlic, 30g corn starch, appropriate amount of honey, appropriate amount of oil</p> <ol style="list-style-type: none"> 1. Wash the chicken wings, soak in water for 20 minutes, and drain; 2. Pour in the corn starch, then the seasonings, mix well, and marinate for 1 hour; 3. Lay the chicken wings on a baking tray, place them in the top layer of the microwave steam oven, and select P06. 	top layer
P07	Roasted Rack of Lamb	<p>5 pieces of lamb chops, 1 onion, 3 green onions, 6 slices of ginger, 1 teaspoon of salt, 2 tbsp of light soy sauce, 1 tsp rice wine, 1 tsp honey, 4 tsp cumin powder, 2 tsp garlic powder, white pepper 1 tsp, red chili powder 1 tsp</p> <ol style="list-style-type: none"> 1. Marinate the lamb chops with onions, ginger, salt, light soy sauce, rice wine, and honey for 2 hours; 2. Mix the powdery seasonings evenly to make a marinade; 3. Cut the onions into sections and place them on the bottom, then put the lamb chops on top; 4. Evenly coat both sides of the lamb chops with marinade; 5. Place in the top layer of the microwave steam oven and select P07; 6. For the remaining 10 minutes, turn the lamb chops over and continue grilling. 	top layer
P08	Hamburger Steak	<p>200g minced beef, 150g minced pork, half onion (chopped), 1 egg</p> <ol style="list-style-type: none"> 1. Mix all burger ingredients and marinade evenly and press into a patty shape. 2. Place the burger steak on the baking tray, place it in the top layer of microwave steam oven, and select P08. 	top layer
P09	BBQ Pork	<p>400-500g Pork scotch fillet</p> <p>Seasonings: 1 tbsp salt, 4 tbsp sugar, 1/4 tsp chicken powder, 1 egg, 2 dried onions, 2 cloves of garlic, 1 stalk of coriander, 1 tablespoon of preserved beans (chopped), 1/2 tsp of rose wine, 4 tbsp of maltose, a small amount of ginger paste.</p> <ol style="list-style-type: none"> 1. Prepare marinade seasoning. First saute the dried onions, minced garlic, coriander and preserved beans until fragrant. Then add sugar, salt, natural chicken powder and eggs. Mix well and ferment at room temperature for 6 hours. 2. The next day, mix the rose wine into the fermented seasonings and marinate for half an hour or above. Cut the pork into long pieces. 3. Add seasonings to pork and marinate for 45 minutes to 1 hour. 4. Place the marinated pork on the baking tray, place it in the top layer of microwave steam oven, and select P06. 5. After baking is completed, take out the barbecued pork and apply the maltose that has been boiled and dissolved in water on the barbecued pork. 6. Place it in the microwave steam oven and bake in the "upper and lower grill" mode for 15 minutes. Take it out again. Coat the other side with maltose and continue baking for 15 minutes. 	top layer
P10	Boiled Eggs	<p>4 eggs</p> <ol style="list-style-type: none"> 1. Place the eggs on steam tray, place the tray in the bottom layer of microwave steam oven and select P10. 	bottom layer
P11	Roasted Sweet Corns	<p>2 sweet corns</p> <p>Seasonings: 2 tbsp olive oil, 2 tsp cumin powder, 1 tsp cheese powder, 1 tsp salt, 1 tsp black pepper</p> <ol style="list-style-type: none"> 1. Divide the corn into 3 sections and cut each section into 4 pieces; 2. Mix the seasonings and set aside; 3. Lay the corns flat on baking tray and apply seasonings; 4. Place in the top layer of the microwave steam oven and select P11. 	top layer

Others

Recipe no.	Dish	Recipe	Accessory location
P12	Roasted Sweet Potatoes	3 sweet potatoes (about 100g each) 1. Clean the sweet potatoes and place them on baking tray; 2. Place the tray into the top layer of microwave steam oven and select P12.	top layer
P13	French Fries	Frozen French fries 200g 1. Frozen French fries do not need to be defrosted and poured into air fry basket. Lay the fries flat on the basket and try to avoid stacking; 2. Place the tray in the top layer of microwave steam oven and select P13.	top layer
P14	Small Buns	250g Bread flour, 3g Instant yeast, 5g salt, 18g sugar, 30g unsalted butter, 220ml milk 1. Soften unsalted butter at room temperature. 2. Mix bread flour, instant yeast, salt, sugar and milk to the mixer and mix for 20 minutes. 3. Add softened unsalted butter to the dough, and keep mix for about 15 minutes. 4. Cut the dough into 12 equal parts. 5. Put baking paper on bake tray and put 6 dough on the tray then put it in the top layer of the microwave steam oven and select P14. bottom layer of microwave steam oven, and select P08.	bottom layer
P15	Pizza	250g High-gluten flour, 150ml water, 4g salt, 1/2g Instant yeast, red peppers, basil, cheese, grilled chicken 1. Dissolve salt in water, add 10% flour and mix well, then add Instant yeast and mix well. 2. Add the remaining flour in batches and knead into a round dough with your hands. 3. Cover the dough with a semi-dry wet cloth and let it rest for a while. 4. Deflate and roll it into a round shape, then place it in the refrigerator to let it ferment and double in size. 5. After taking the dough out of the refrigerator, it needs to be warmed for one hour. 6. Form into a 12-inch pizza shape, add red pepper, basil, cheese and grilled chicken. 7. Place the pizza on the baking tray, place it in the bottom layer of microwave steam oven, and select P15;	bottom layer
P16	Yogurt	750ml Pure milk, 50ml plain yogurt, 40g sugar 1. The cheese-making utensils must be scalded in boiling water and air-dried to ensure there is no oil or water; 2. Heat the pure milk to about 40 degrees, turn off the heat, heat the sugar and stir evenly; 3. When the temperature of the milk is lower than 40 degrees, add yogurt to make yeast and stir evenly; 4. Place the yogurt into a container for fermentation and seal with plastic wrap or lid; 5. Place it on the bottom layer of microwave steam oven and select P16.	bottom layer
P17	Blueberry Cream Cheese Cake	120g Blueberries, 2 eggs, 150g sugar, 50g vegetable oil, 1/2 tsp vanilla oil, 220g sour cream, 250g low-gluten flour, 1/2 tsp salt, 1/2 tsp soda powder, little cream cheese 1. Wash blueberries and set aside. 2. First put the eggs and sugar into a large bowl and beat with an electric egg beater until light yellow. Add vegetable oil and vanilla oil and mix well. Finally, add sour cream and mix into egg liquid. 3. Sift the cake flour, salt and baking powder through a sieve. 4. Add the sifted flour to the egg mixture, then add the blueberries. 5. Pour the egg mixture into the waffle mold, fill it to about 70% full, and add cream cheese. 6. Place the baking tray into the bottom layer of the microwave steam oven and select P17.	bottom layer

Others

Recipe no.	Dish	Recipe	Accessory location
P18	Apple Pie	<p>Ingredients for the dough: 90g unsalted butter, 1 tsp sugar , 3g salt, 180g all-purpose flour, 2 egg yolks, 2 tbsp ice water, 1 egg white.</p> <p>Filling: red & green apples 6 each, 1 tsp lemon juice, half lemon (in slice), nutmeg powder, 1 tsp golden cane sugar, a little walnut or almond slices, little dried cherries.</p> <ol style="list-style-type: none"> To make the pie, mix unsalted butter, sugar and salt until soft. Add all-purpose flour, mix briefly and add egg yolks and ice water. After kneading into a smooth dough, use rolling pin to gently flatten it into a square shape. Wrap with plastic cling and put into refrigerator for at least 1 hour. Take out the dough and let it sit at room temperature for 30 minutes. Then place the dough between 2 pieces of butter paper, roll it to 5 cm thick and tear off the butter paper. Place the dough into a 10-inch mold, prick holes with a fork, and apply white egg around the dough. Place the dough back in the refrigerator. To make the filling, wash and slice the red apples and green apples, add lemon juice, mix lemon juice, cardamom powder and golden cane sugar together, then cook over low heat until soft. Use a strainer to drain away the water and let cool. Use a rolling pin to crush the walnuts or almond slices lightly, then add the dried cherries; then pour into the filling and mix well. Take out the pie from the refrigerator, pour the filling evenly into pie, and wipe a little egg paste. Place the apple pie on baking tray and put it into the top layer of microwave steam oven and select P18. 	top layer
P19	Defrost chilled food (500g)		bottom cavity
P20	Semi-defrost thawed meat (500g)		bottom cavity
P21	Defrost thawed meat (500g)		bottom cavity

Operation Instructions

■ Residual Heat Indicator

In standby or energy-saving mode the  “Residual Heat Indicator” icon will be shown to warn that cavity exceed 50°C and is not suitable for cleaning. The icon will be off until cavity drops below 50°C. Users should not clean the appliance until the icon is off.

■ Child Lock

Steamer is equipped with child lock so that children cannot switch on or change any setting accidentally.

A. Activating the Child Lock:

Press and hold the  “Child Lock” button for 3 seconds. Child lock is enabled. The “Child Lock” icon lights up (as shown in the diagram below).



B. Cancelling the Child Lock:

Press and hold the “Child Lock” button for 3 seconds to disable the child lock function. The “Child Lock” icon goes off.

Cleaning and Maintenance

■ Cleaning and Maintenance

1. Under normal circumstances, cleaning is the only maintenance required.
2. Cleaning and maintenance should only be carried out when the combi steamer is cool and the  Residual Heat Indicator icon disappeared. Disconnect the power plug from the main power supply before cleaning. Do not use any steam cleaner to clean this appliance.
3. To avoid corrosion which would shorten the useful life of your combi steamer, always keep it clean. Always clean the appliance after use.
4. To avoid damage to the steam microwave oven body, control panel, oven walls and accessories, do not use any cleaning cloth that contains metal, scrubbing cleaners, steel brush or cloth with a rough surface for cleaning. Use a sponge or cloth soaked in gentle detergent or kitchen towel paper sprayed with glass cleaner to clean the appliance. Always make sure the cavity (including the bottom) is completely dried after use.
5. Salt is a corrosive substance that would result in rust stains if left to build up inside the oven. Acidic sauces, such as ketchup, mustard and preserves, contain chemicals like chlorine and acids which would damage the stainless steel surface.
6. Do not allow grease and food debris to remain on the oven door and door seal. If the door seal is not kept clean, the oven door may fail to close when the appliance is in operation. This would cause damage to the front and sides of the combi steamer.
7. After each use:
 - i) Empty the drip tray under the oven dooto prevent overflow, splash and soiling of the worktop. (The drip tray can be removed. It collects condensation water every time after use when door is opened
 - ii) Empty the water tank.
 - iii) Always leave the door opened for 15-30 minutes or run the Cavity Drying Mode to dry the oven and door frame.
8. If the oven is very dirty, run the Steam mode (110°C) to remove grease and dirt with steam for 30 minutes before cleaning. Do not start cleaning until the appliance has cooled down. For stubborn grease stains, repeat these steps several times. Never use any cleaning cloth that contains metal, scrubbing cleaners, steel brush or cloth with a rough surface for cleaning.
9. It is suggested to run the Descaling Mode at least once a month or when the descaling icon lights up.
10. Tap water, drinking water or distilled water is suggested for steaming function. Avoid using mineral water.
11. The water tank must be checked at least once a month. Clean it if necessary and put it back correctly.
12. Disconnect the main power if the appliance will not be used for a long period. Keep the oven clean and put the appliance in a dry place away from corrosive gases.
13. After every use, clean and air dry the oven (including the top, sides and bottom). If discoloration is detected at the bottom or inside the oven, remove the stains with a stainless steel cleaner (e.g. Wpro Steel Cleaner).

Cleaning and Maintenance

⚠ WARNING



Attention

Oven maintenance should only be carried out after unplugging the power plug, wait for the cavity cool down thoroughly.

Failure to do so may result in electric shock, injury or burns.

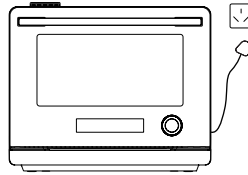

Do Not

Do not plug or unplug the power plug with wet hands Failure to do so may result in electric shock.

Failure to do so may result in electric shock.



Do Not

It is strictly prohibited to immerse the microwave steam oven in water or other in liquid

Failure to do so may result in electric shock or injury.

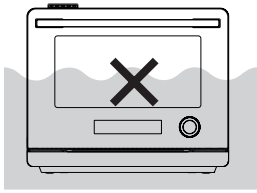

Do Not

Do not heat the oven if there is oil or food residue inside or on the door.

Microwaves will concentrate on dirty parts, which may cause dangers such as sparks, smoke, and fire. Additionally, rust will occur.

- If there is dirt on it, be sure to clean it every time after the oven cavity cools down.

⚠ CAUTION



Do Not

Do not use household detergents (alkaline, acidic, etc.), oven cleaners, powdered cleaners, styrene, diluent, bleach, hot water, flammable gas (LPG, etc.) spray cleaners, scouring pads, sponges Hard parts, metal cleaners, etc.

Sponge scouring pad



Do not use hard rough part to clean the appliance (Non-woven fabric with rough surface)

Please use the soft sponge part for cleaning

Rough surface scouring pad



Do not use this type of scouring pad for cleaning. Please use cleaning products with non-abrasive surfaces

Cleaning and Maintenance

■ Cleaning and Maintenance

Cavity

Wipe with a damp towel that has been wrung dry.

※ For dirt that is difficult to remove, please place a wet towel on the dirt for about 30 minutes and wait until the dirt softens before wiping; After steam cooking, please wait for the moisture condensed to cool down before wiping it with a towel;

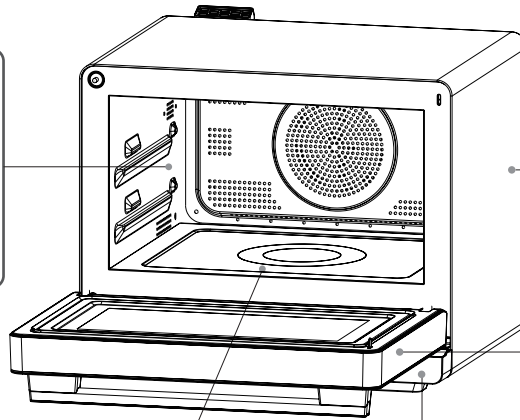

Body and oven door

Wipe with a damp towel that has been wrung dry.

※ When there is serious dirt, please use a towel with diluted kitchen detergent (neutral) to remove the dirt, and be sure to wipe the detergent away thoroughly.

Cavity bottom (ceramic glass)

Wipe the dirt on the bottom of the oven cavity immediately with a damp cloth.

The dirt caused by using microwaves may become burnt when baked. When the dirt is difficult to remove, please run the steam mode at 100°C for 20 minutes, and then wipe it off with a damp cloth.

The steam can penetrate into the underlying soil, making it easier to remove.

Do not use sharp objects, such as, steel brushes or forks to remove dirt, otherwise it may cause damage or cracks to the appliances.

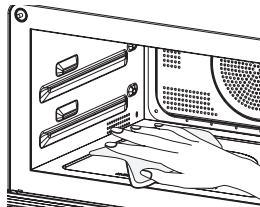

Drip tray and water tank

Wash with water and a soft sponge to remove dirt and dry thoroughly. If there is serious dirt, please clean it with diluted neutral detergent. Do not put it in a dishwasher, tableware dryer, or place it directly in the sun for drying, otherwise the water tank and drain plate may be deformed or damaged.

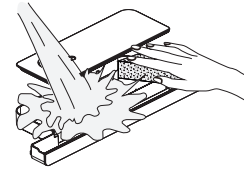

Others

■ Troubleshooting

A. Possible Problems

	Problem	Cause	Solution
1	No Display	Steam microwave oven is not connected to power supply	Ensure it is connected to power supply
		Malfunction of power socket	Check if other electrical appliances work normally
		Power cords is not working	Contact after-sales service
2	Steam microwave oven is not working	Power supply plug is not connected correctly	Try to plug in the power supply again
		Oven door is not closed properly	Close the oven door again
		Water tank is not in a correct position	Put the water tank back correctly
		Circuit board is damaged	Contact after-sales service
		Child lock is enabled	Disable the child lock
3	Display is not working properly	Display is damaged	Contact after-sales service
		Circuit board is damaged	
4	Lots of Water or steam can be found during cooking	Oven door is not closed tightly	Close the oven door tightly again
		Door seal is damaged	Contact after-sales service
5	Oven light is not working	Light is damaged	Contact after-sales service
		Control board is damaged	
6	Fan motor fails to work properly	Fan motor is damaged	Contact after-sales service
		Control board is damaged	
7	Control panel is not working properly	Control panel is out of order	Contact after-sales service
		Control board is damaged	
8	No steam	Water tube is damaged	Contact after-sales service
		Water pump is damaged	
		Water tank is empty or not in place	
9	Water leakage	The water tank is not in a correct position	Fill the water tank and put it back correctly

Others

B. Following conditions are normal

	Condition	Cause
1	Fame and smell can be detected during the first time of use	These are emitted by the protective oil and it is normal.
2	Noise can be heard using any steam related mode	This is normal during water pumping into machine for steaming.
3	Water condensation can be found around the ventilation vent or door	The steam microwave oven produces a large amount of steam under steam cooking mode. Most of the steam will be vented from the frontal ventilation and some condensation water will be found around the ventilation vent.
4	The fan continues to work after cooking is finished	The fan will continue to run for 3 minutes after each cooking mode for cooling purpose to discharge oven heat completely. It is normal.
5	White powder can be found around the air inlet	This is water scale. It is normal. If white powder (water scale) is detected, it is recommended to run the Descaling Mode for cleaning purpose.
6	Bottom and cavity of oven's color has yellowing.	Stainless steel will generate yellow marks when heated and not kept clean. It is recommended to clean the combi steamer after each use to avoid the yellowing issue caused.
7	Voltage fluctuations will affect the cooking effect	When the voltage fluctuates in the range of -10% to +5%, the microwave steam oven still can operate. However, affected by low or high voltage, the output power will decrease or increase relatively and affects the cooking effect, which is normal.

Others

■ Product Specifications

Model	MWP269TMS
Rated Voltage and Frequency	220-240V~ 50/60Hz
Rated Input Power	2100W
Microwave Input Power	1500W
Microwave Operating frequency	2450 MHz
Product Dimension (H x W x D)	367 x 450 x 458mm
Cavity Dimension (H x W x D)	201.5 x 380 x 320mm
Oven Capacity	26L
Net Weight	Approximately 19kg

Register your product online

網上登記新產品保養

香港 Hong Kong



Scan QR Code or visit
www.whirlpool.com.hk
to register your product warranty online.

You can download the user manual by:

- Visiting Our website **www.whirlpool.com.hk**
- Contacting our Customer Service at (852) 2406 9138.

掃描二維碼或登入
www.whirlpool.com.hk
以進行網上產品保養登記

可透過以下途徑下載使用說明書:

- 瀏覽我們的網頁 **www.whirlpool.com.hk**
- 致電我們的客戶服務中心 (852)2406 9138

新加坡 Singapore



Scan QR Code or visit
www.whirlpool.com.sg/warranty-registration
to register your product warranty online.

You can download the user manual by:

- Visiting Our website **www.whirlpool.com.sg**
- Contacting our Customer Service at (65) 6250 6888
or email **helpdesk.sg@whirlpool.com**

掃描二維碼或登入
www.whirlpool.com.sg/warranty-registration
以進行網上產品保養登記

可透過以下途徑下載使用說明書:

- 瀏覽我們的網頁 **www.whirlpool.com.sg**
- 致電我們的客戶服務中心 (65)6250 6888
或電郵至 **helpdesk.sg@whirlpool.com**

Whirlpool® Registered trademark/TM Trademark of Whirlpool group of companies

All rights reserved - <http://www.whirlpool.com.hk>

註冊商標/惠而浦集團的TM商標

版權所有 翻印必究 - <http://www.whirlpool.com.hk>

