

Whirlpool® Registered trademark/TM Trademark of Whirlpool group of companies

All rights reserved - <http://www.whirlpool.com.hk>

註冊商標/惠而浦集團的TM商標

版權所有 翻印必究 - <http://www.whirlpool.com.hk>



**Whirlpool**

**Whirlpool**

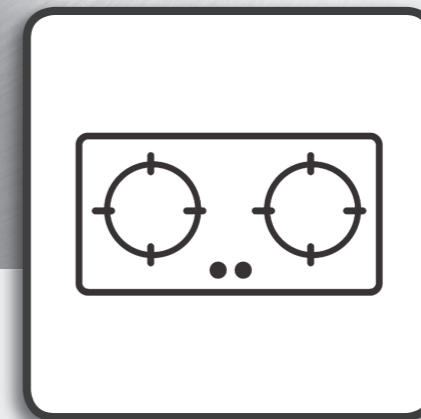

## Health & Safety, Use & Care and Installation guide

產品安全指引、使用說明及安裝指南

Model 產品型號 : GWG3010TH

GWG3010LH

GWG3020TH

GWG3020LH



[www.whirlpool.com.hk](http://www.whirlpool.com.hk)



## AFTER-SALES SERVICE

Before calling the After-Sales Service, make sure you can give the following information:

SERIAL NO. 0000 000 00000



- type of fault or problem;
- exact model (written on the label affixed to the instruction / warranty);
- serial number that follows the word SERIAL NO. on the rating plate under the hob and on the label affixed to rating labels / warranty;
- your complete address and phone number.

If any repairs are required, please contact an authorised After-Sales Service, as indicated in the warranty.

## 目錄

重要的安全指示	02
安裝說明	03
清潔提示	05
保護環境	06
產品描述	06
對於使用燃燒器的建議	07
如何使用爐具	07
故障排除指南	08
技術規格	09
售後服務	10

## 重要的安全指示

### 您和他人的安全是非常重要的

本手冊和產品本身提供許多重要的安全信息，務必閱讀並且遵守這些安全信息。

 這是安全警告標誌。這標誌是告訴您，有潛在的危險並可能引致您或他人的死亡或受傷。所有的安全知識都可在警告標誌及「危險」、「警告」字樣之後找到。這些字樣表示：

 **危險** 表示一種危險情況，如果不避免，將造成嚴重的傷害。

 **警告** 表示一種危險情況，如果不避免，可能會造成嚴重的傷害。

所有安全信息會告訴您那些潛在的危險，教您如何減少受傷的機會，並告訴您，若不遵照指示將會發生什麼後果。

 **警告** 如果不完全遵守本手冊中的信息，可能會造成火災或爆炸，導致財產損失或人身傷害。

- 不要在爐具的附近存放或使用汽油或其他易燃氣體和液體。

如果您嗅到氣體味時：

- 不要試圖燃點任何爐具。
- 不要觸摸任何電器開關。
- 不要在您的建築物內使用電話。
- 要關閉燃氣供應閥，離開現場才使用電話聯絡您的燃氣供應商。
- 如果您聯絡不到您的燃氣供應商，請立即報警。
- 請在通風良好的房間內使用此爐具設備。

- 本機只提供一般家庭使用，不作商業用途。
- 不要使用這設備作為空間加熱器來加熱室內的溫度。這樣做可能會導致一氧化碳中毒和爐具過熱。製造商對於不當使用或不正確控制設備的行為是不會負責任的。
- 本產品不適合身體、感官或精神上有缺陷或缺乏經驗和知識的人（包括兒童）使用，在未經過任何指導或者監護人情況下，切勿讓兒童或殘弱人員操作。
- 兒童使用時需有成年人監督，確保他們不會將爐具當作玩具。
- 在室內使用燃氣設備時，會產生熱量和濕度。請確保房間通風良好，或已安裝油煙機與排氣管。
- 如果需要長時間使用，額外的通風是必要的（請打開窗戶或增加油煙機排氣速度）。
- 使用後，請確保旋鈕處於關閉位置和關閉主燃氣供應旋鈕或氣瓶閥。
- 過熱的油和油脂很容易著火。當烹煮含有豐富脂肪油的食物或酒精（如：甜酒、白蘭地、葡萄酒），請時常保持警惕。
- 請將包裝材料放在兒童拿不到的地方。
- 請等待爐具降溫後才進行清潔或護理。
- 本產品不適合用於室外安裝和操作。
- 如火焰在使用過程中吹熄，安全閥會自動切斷燃氣供應，於一分鐘後才可重新點燃。
- 點燃後檢查火焰是否均勻正常；移走煮食器皿時，先把爐火調小或關閉。
- 請勿放過大或過重的煮食器皿於爐架上，以免損壞爐架及令過多熱量反射回到爐面，造成損壞。
- 如需維修或更換零件，請與本公司維修部聯絡，並必須使用原裝配件。在保養期內，如因人為損壞、錯誤或不恰當使用爐具而導致之損壞，本公司會收取零件及維修費用。
- 本煮食爐的最高負載重量為10公斤。

## TECHNICAL SPECIFICATIONS

<b>Model No.</b>	GWG3010TH	GWG3010LH
<b>Gas Type</b>	Hong Kong Town Gas	Hong Kong LP Gas
<b>Rated Heat Input</b>	6.0kW	5.0kW
<b>Gas Working Pressure</b>	1.5kPa	2.9kPa
<b>Electric Supply</b>	DC1.5V(D-type Battery)	
<b>Ignition Method</b>	Pulse Ignition	
<b>Safety Devices</b>	Flame Failure Device	
<b>Dimensions</b>	(H)125mm(W)290mm(D)515mm	

<b>Model No.</b>	GWG3020TH	GWG3020LH
<b>Gas Type</b>	Hong Kong Town Gas	Hong Kong LP Gas
<b>Rated Heat Input</b>	(T)2.5kW	(T)1.8kW
	(B)1.3kW	(B)1.1kW
<b>Gas Working Pressure</b>	1.5kPa	2.9kPa
<b>Electric Supply</b>	DC1.5V(D-type Battery)	
<b>Ignition Method</b>	Pulse Ignition	
<b>Safety Devices</b>	Flame Failure Device	
<b>Dimensions</b>	(H)115mm(W)290mm(D)515mm	

## HOW TO HANDLE SAFETY DEVICE AND CHANGE BATTERY

- If the flame goes out accidentally during operation, the automatic Flame Failure Safety Device will shut off gas supply after a short delay. Turn the knob to “ ● ” position when this happens.
- The Safety Sensor is very delicate-please do not use hard brushes or rough cleaning pads when cleaning.
- Aeration is set at factory, please do not attempt to adjust it.
- Battery Box is located at bottom (D Size 1.5x1). Open the door of battery box and change battery.
- Put battery at correct polarity (“+” and “-”).

## KIND REMINDER

- When the appliance has been operated for 30 minutes, the glass top plate and rotary knobs of the appliance might become hot due to the heat from flame. In case of using the rotary knobs, please use a moisten towel to cool down before usage.
- Pop sound might be generated during flame extinguishing due to instant combustion of gas remained in burner. This is a normal phenomenon.
- When operating at low flame, do not open underneath cabinet door rapidly; otherwise flame may be extinguished by air draught.
- When adjust flame power from maximum close to medium, if flame of outer ring burner is found unstable (weak or extinguished), please adjust the flame power to maximum until flame of outer ring burner is stable, or reduce flame power and use flame of simmer burner.

## TROUBLESHOOTING GUIDE

If the hob was not operated correctly, please refer to the Troubleshooting Guide to determine the problem, before calling the After-Sales Service.

### 1. The burner fails to ignite or the flame is uneven

Check that:

- The gas cylinder (liquid gas) is not empty.
- The burner openings are not clogged.
- All the burner parts have been positioned correctly.
- Spark electrode is wet especially when humidity level is high.
- Battery needs to be replaced.

### 2. The burner does not stay lit

Check that:

- When lighting the burner, the knob has been pressed for enough time to activate the protection device.
- The burner openings are not clogged near the thermocouple.
- The end of the safety device is not dirty.

### 3. The cooking pan or pot are not stable

Check that:

- The bottom of the cooking pan / pot is perfectly flat.
- Cooking pan/pot is correctly positioned at the grid .
- The grids have not been interchanged or positioned incorrectly.

### 4. Yellow flame

Check that:

- Grease and dirt accumulate on burner head. Wash burner head in warm water with detergent. Mop it dry and then place back in correct position.

### 5. Smell of gas

Check that:

- Close the gas valve, leave the scene and then call your supplier.

If after the above checks the fault still occurs, get in touch with the nearest After-Sales Service.

## 安裝說明

### 注意

- 根據香港氣體安全條例，任何氣體裝置工程，包括爐具和接駁喉管的安裝，必須由註冊氣體裝置技工執行，而該技工已於相關的氣體工程類別註冊及受聘於註冊氣體工程承辦商。
- 收貨後請立即拆盒驗機，以確保它沒有在運輸過程中遭到損壞。如若發生問題，請與經銷商或惠而浦售後服務聯絡。
- 於櫥櫃檯面安裝嵌入式氣體煮食爐時，爐櫃應設有活風透氣設施，以確保煮食爐在使用時操作正常。
- 不應將易燃物料、噴霧及壓縮容器放置在爐櫃內。
- 氣體的連接必須符合本地的法例。
- 若未能遵守這些要求，製造商可以不承擔任何引起人或動物或財產損失造成的責任。

## 給與安裝人員的技術信息

- 使用防護手套去處理，準備和安裝此產品。
- 安裝前，請確保：
  - 當地的氣體輸送狀態（性質和壓力）與爐具的設置是兼容的（見銘牌和爐具上的資訊）；
  - 與爐具相鄰的家具或電器，其外表面必須是耐熱性而按照本地法例規定；
  - 此設備沒有連接到減煙裝置，應根據現時的安裝規定對設備進行安裝，並應特別注意要按照本地法例規定的通風規定要求。
  - 燃燒產物必須通過特定的抽油煙機或牆壁和 / 或窗口式安裝抽氣扇外排出。

## 安裝注意事項

所有爐具必須由註冊氣體裝置技工安裝，切勿自行安裝，否則惠而浦（香港）有限公司概不負責一切引致的損毀及責任。

- 安裝前必須確保煮食爐具已根據府上的供氣類別進行調校。
- 爐具須安裝在空氣流通房間內，附近可以置易燃物品如紙張、油類等。
- 爐具須放置在穩固之平面上。
- 如果安裝爐具於易燃物料附近（如木牆、木架），兩側的安裝距離須有15厘米（6英吋）以上，此爐具的安裝位置應與周圍易燃物料距離15厘米以上。
- 距離底部不少於2.5厘米（1英吋）。
- 不需安裝外置氣體穩壓器。

## 爆炸危險

- 安裝本產品時,必須緊固所有氣體連接處。
- 緊固後，請用肥皂水檢查所有氣源連接處，確保無氣泡、洩漏產生。
- 不遵守上述操作，有可能導致人身傷害。

## I. 房間內通風

保持正常氣體燃燒及有關房間通風所需之空氣量，體積必須不少於 $20\text{m}^3$ 。空氣應自然流經房間內的固定窗戶或通風口。窗戶或通風口面積最少為 $100\text{cm}^2$ ，並確保不被阻塞。

## II. 氣體接駁

安裝前先查看爐具底部標貼列出的規格是否與安裝地點的氣體及電力供應系統互相符合。爐具標貼列明氣體類別及操作壓力。氣體接駁必須符合有關法例。入氣咀的直徑為 $\frac{1}{2}$ 吋。

### A. 石油氣接駁

- 使用軟喉接駁：請使用合格印有機電工程署批准標記(例如：機電工程署批准EMSD APPROVAL GTXXXX字樣)之軟喉及氣掣進行接駁，由爐後面喉咀接駁至供氣點。

- 使用不鏽鋼網喉接駁：請使用合格印有機電工程署批准標記(例如：機電工程署批准EMSD APPROVAL GTXXXX字樣)之不鏽鋼網喉及氣掣進行接駁，由爐後面 $\frac{1}{2}$ 吋B.S.P喉牙接駁至供氣點。

### B. 煤氣接駁

- 請使用合格印有機電工程署批准標記(例如：機電工程署批准EMSD APPROVAL GTXXXX字樣)之不鏽鋼網喉及氣掣進行接駁，由爐後面 $\frac{1}{2}$ 吋B.S.P喉牙接駁至供氣點。

## III. 櫃面開孔尺寸

型號	A	B
GWG3010TH	265mm	490mm
GWG3010LH		
GWG3020TH		
GWG3020LH		

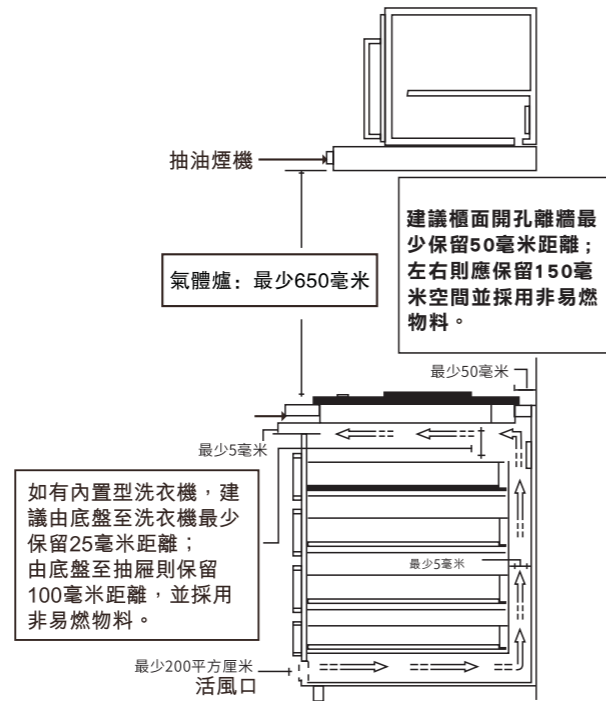
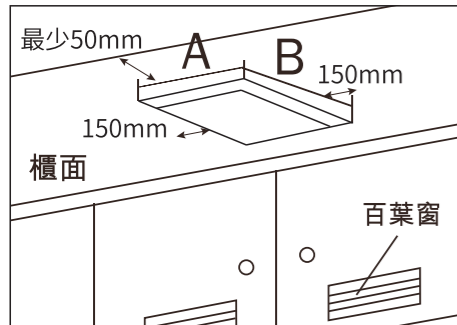

以上之安裝圖不按比例繪畫

## USEFUL ADVICE FOR USING THE BURNERS

This hob has burners of different diameters. For better burner performance, please refer to the following rules:

- Use pots and pans with bottoms of the same width or slightly larger as that of the burners.
- Use the correct amount of water for cooking foods and keep the pot covered.
- Make sure pots on the grates do not protrude beyond the edge of the hob.

**IMPORTANT: Improper use of the grids can result in damage to the hob: do not position the grids upside down or slide them across the hob.**

**Do not use:**

- Cast iron griddles, terracotta pots and pans.
- Heat diffusers such as metal mesh, or any other types.
- Two burners simultaneously for one receptacle.

## HOW TO USE THE HOB



**WARNING**

**Do not let the burner flame extend beyond the edge of the pan.**

**IMPORTANT: WHEN THE HOB IS IN USE, THE ENTIRE HOB AREA MAY BECOME HOT.**

### Attention

The use of a gas cooking appliance produce heat and moisture, so it is essential to ensure that the kitchen is well ventilated.

Keep natural ventilation windows open or install a mechanical ventilation device (mechanical extractor hood).

Prolonged intensive use of the appliance may need additional ventilation, for example opening window or increasing the level of mechanical ventilation where present.

The top panel of this cooker is made of tempered glass which is safer than normal glass for this application. However, the following safety precautions for using hob with glass top panel should also be order to prevent the glass top panel from breaking:

1. Clean the burner assembly frequently to maintain a clear gas passage on the flame distributor. Clean and tidy up the flame distributor after spillage of food and liquid once the burner assembly cooled down.
2. Turn off the gas appliance immediately if abnormal noise propagates from the gas appliance and contact gas supply company or gas hob importer for inspection.
3. Do not use oversized utensils for cooking.
4. Do not impact the glass surface with hard objects or place heavy objects on the glass surface.

Do not use additional fitting, such as aluminium foil.

Do not clean the top of the sensor with a hard brush, as it may damage the sensor.

1. While pushing the control knob, turn it to the left (towards the "🔥" position) slowly until you hear a 'click' sound. Electronic spark will ignite burners. Release your hand after confirm the burner is ignited. The hob has automatic continuous ignition function, do not need to continually push the control knob after ignition. 'Click' sound and spark will be stopped automatically after 6-8 seconds.
2. If the flame goes out when you release your hand, repeat the ignition procedure again but try release your hand slowly.
3. Turn Control knob to adjust flame to desirable setting.
4. Flame can be adjusted between "🔥" and "●". Please adjust flame slowly (Fig.4&5).
5. Turn the ignition Control Knob backwards to the "●" position to extinguish the burner.

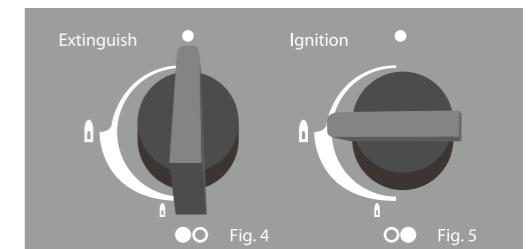

## SAFEGUARDING THE ENVIRONMENT

### Scrapping the product

- By ensuring this product is disposed of correctly, you will help prevent potential negative consequences for the environment and human health, which could otherwise be caused by inappropriate waste handling of this product.

## PRODUCT DESCRIPTION

GWG3010TH  
GWG3010LH

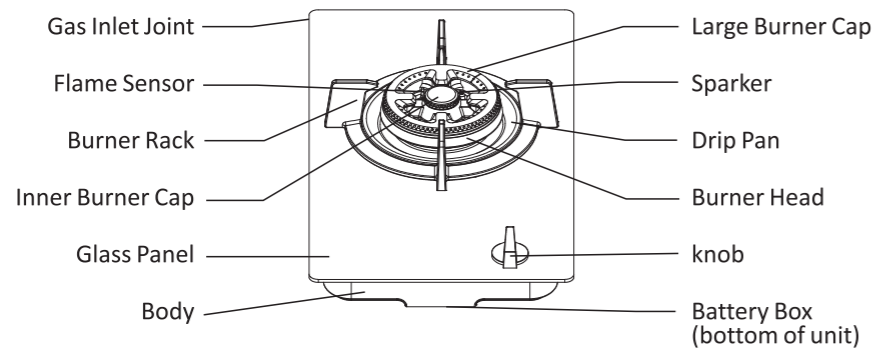

GWG3020TH  
GWG3020LH

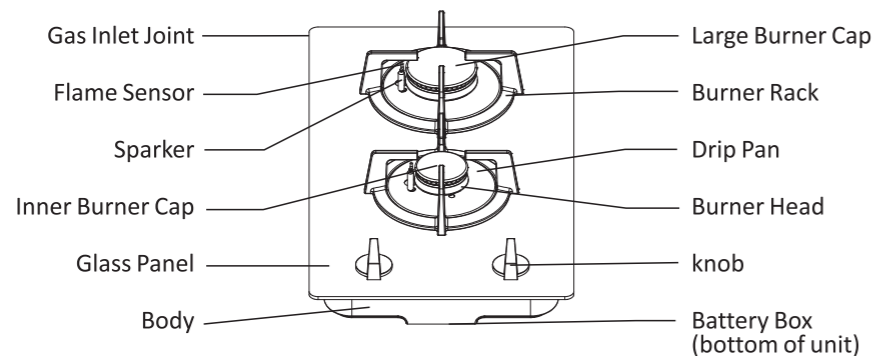

## IV. 爐架及爐頭之正確位置

使用前請先確定以下配件已置於正確位置。

### 1. 爐架

爐架正確地安放在爐蝶上（圖1），放置時，請勿傾斜，否則會影響爐火不正常。

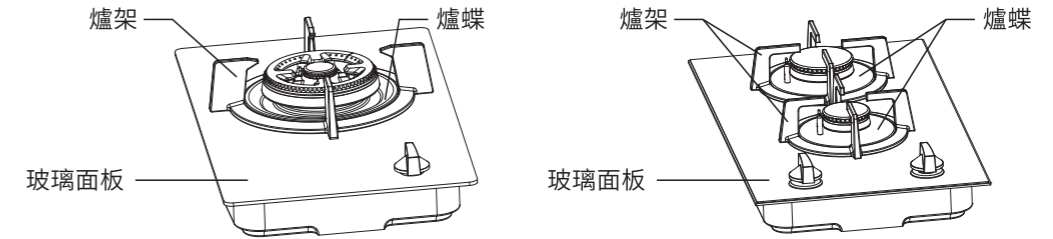

### 2. 爐頭

小銅蓋和大銅蓋分別放置在爐頭上（圖2），放置時請勿傾斜及不要留有空隙（圖3）。若兩者不正確地放置使用爐具會導致爐頭變形、玻璃破裂和增加釋放一氧化碳危險。

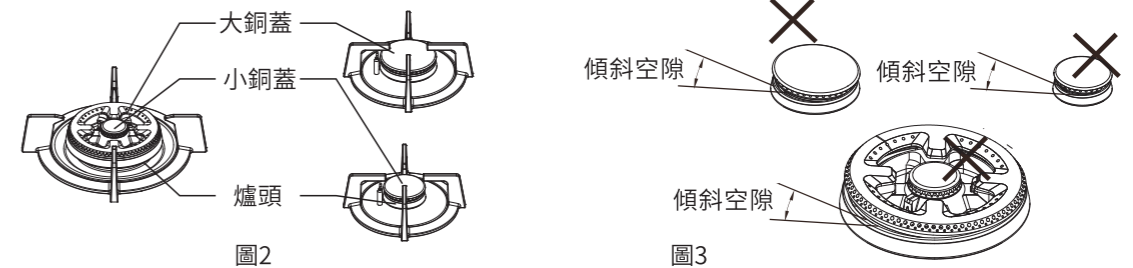

## 清潔提示

### 清洗爐具表面



危險

在清潔之前，請關閉供氣喉。

- 所有搪瓷和玻璃部分，請用溫水和中性清潔劑清洗。
- 若果石灰水或腐蝕性的清潔劑留在表面太久，玻璃可能會被染色。若食物溢出（水、醬油、咖啡等），應在它們變乾前擦掉。
- 用溫水和中性清潔劑去清潔表面，然後用乾布抹掉。
- 請勿使用磨蝕性或腐蝕性的產品，或含氯的清潔劑或硬毛刷去清潔。
- 切勿使用蒸汽清潔用具。
- 請勿使用易燃品。
- 不要將酸性或鹼性物質，如醋、芥末、鹽、糖或檸檬汁倒在爐具上。

### 清潔爐具配件

- 爐架、小銅蓋、大銅蓋和爐頭都可以拆下來進行清洗。
- 請用手和溫水以非磨蝕性清潔劑進行清潔，去除任何食物殘渣及檢查以確保銅蓋火孔沒有堵塞。
- 清洗後請風乾。
- 依照爐架及爐頭安裝圖重新安裝爐頭及大、小銅蓋。
- 當更換爐架時，確保油鍋範圍與燃燒器對齊。
- 爐具配備脈衝點火和熄火保護裝置，點火針需要保證徹底清洗，以確保正常使用。需經常檢查這些配件，如有需要，可以用濕布進行清潔。食物殘渣可用牙籤或針去除。  
注意：為了避免電子點火裝置損壞，當爐頭不在正確位置內請不要使用。

## 保護環境

### 銷毀產品

- 請確保本產品正確處置，有助於避免對環境和人類健康的損害，這產品如若處理不當，可造成潛在的負面影響。

## 產品描述

GWG3010TH  
GWG3010LH

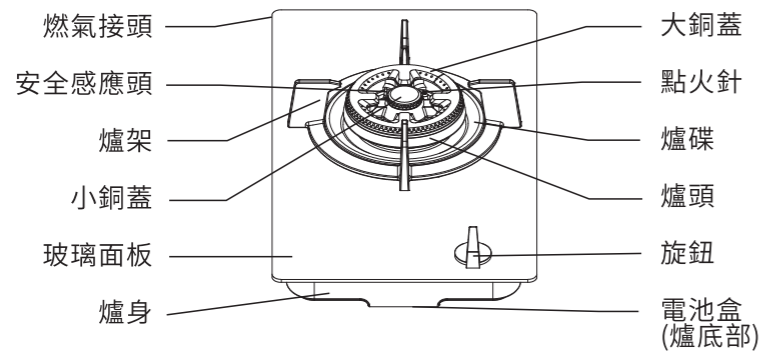

GWG3020TH  
GWG3020LH

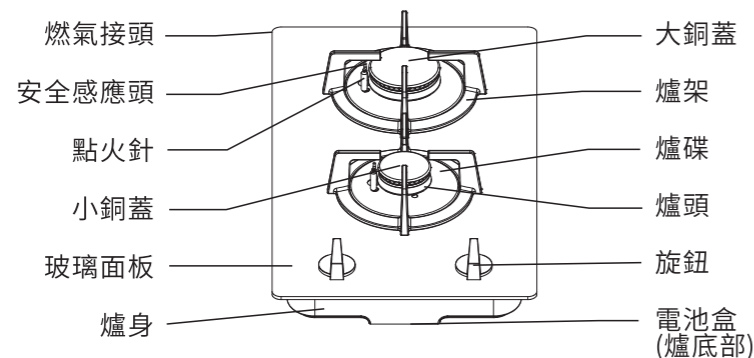

## IV. Correct Position of Burner Rack & Burner Cap

Make sure that the following parts are fitted properly before use.

### 1. Burner Rack

Fit Burner Rack legs into Drip Pan (Fig.1). Please do not tilt the placement, otherwise it will affect the fire is not normal.

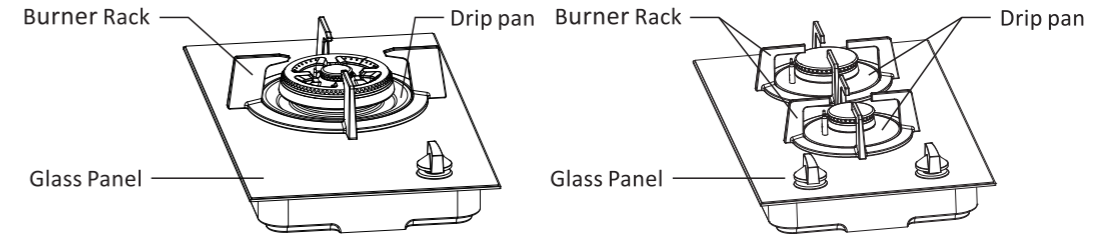

Fig.1

### 2. Burner head

Install the Inner Burner Cap and Outer Burner Cap into Burner Head (Fig.2), do not tilt or leave gap during installation (Fig.3). If incorrect placement for both of them and used, the burner head will be deformed, breaking of glass, and increase the risk of releasing carbon monoxide (CO).

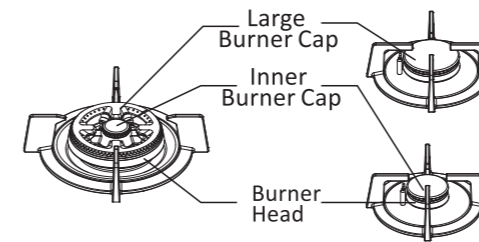

Fig.2

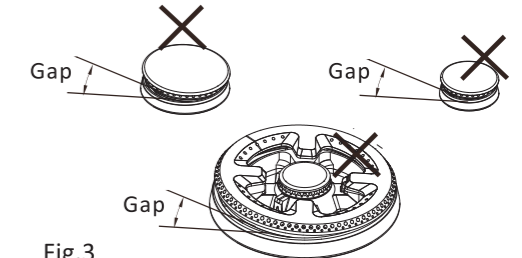

Fig.3

## CLEANING TIPS

### CLEANING THE HOB SURFACE



**WARNING**

Close the gas supply valve before cleaning.

- All the enamelled and glass parts should be cleaned with warm water and neutral solution.
- Glass surfaces may be stained by calcareous water or aggressive detergents if left in contact for too long. Any food spills (water, sauce, coffee, etc.) should be wiped away before they dry.
- Clean with warm water and neutral detergent, and then dry with a soft cloth or chamois.
- Do not use abrasive or corrosive products, chlorine-based cleaners or pan scourers.
- Do not use steam cleaning appliances.
- Do not use flammable products.
- Do not leave acid or alkaline substances, such as vinegar, mustard, salt, sugar or lemon juice on the hob.

### CLEANING THE HOB PARTS

- Grids, burner caps and burners can be removed for cleaning.
- Clean them by hand with warm water and non-abrasive detergent, removing food residues and ensuring that none of the hole in burner is clogged.
- After cleaning, please drying before use.
- Reinstall burners and burner caps correctly according to installation diagram.
- When replacing the grids, make sure that the pan stand area is aligned with the burners.
- This model is equipped with electrical ignition plugs and safety device require thorough cleaning of the plug end in order to ensure correct operation. Check these items frequently, and if necessary, clean them with a damp cloth. Any baked-on food should be removed with a toothpick or needle.

**NOTE: To avoid damaging the electrical ignition device, do not operate the gas hob when the burners are not in correct position.**





## 防漏熄火安全裝置生效時的處理方法

- 如爐頭在使用中火焰突然熄滅，防漏熄火安全裝置會自動切斷燃氣供應。如有此情況，請將旋鈕轉至“●”的位置。
- 感應頭十分精密，切勿使用粗刷子或其他粗糙的清潔用品進行清潔。
- 生產商已調校了風位，切勿嘗試自行調校。
- 電芯盒在爐身的底部（1.5伏特D型鹼性電池×1）。請將盒蓋打開更換電池。
- 請確保乾電池的正、負極安裝正確。

## 溫馨提示

- 於爐具運作約 30 分鐘後，爐具玻璃面及旋鈕部分會有因爐火熱力而變熱。如需使用旋鈕，可以濕布降溫後使用。
- 關閉爐頭時，有機會因殘留在爐頭內的氣體瞬間燃燒而出現響聲，此屬正常現象。
- 使用小火時，不應急速打開爐具下方的櫥櫃門，以免氣流弄熄爐火。
- 在調較最大火力至接近中火時，若發現外環火焰不穩定(微弱或熄滅)，請立即調大火力，直至外環火焰穩定才繼續使用；或調小火力，使用芯火。

## 故障排除指南

如果爐具無法正常使用，在致電售後服務之前，請參考故障排除指南，以確定故障的原因。

### 1. 燃燒器未點燃或火焰不平均

請檢查：

- 氣瓶（石油氣瓶）是不是空的。
- 燃燒器口沒有被堵塞。
- 所有燃燒器部件已經正確定位。
- 爐具附近沒有阻物。
- 點火針是否濕了，特別在濕度高的日子。
- 電池是否需要更換。

### 2. 燃燒器不能保持點燃

請檢查：

- 當點燃燃燒器時，請確保旋鈕已按下足夠的時間去啟動保護裝置。
- 接近熱電偶的燃燒器口不可以堵塞。
- 請保持安全裝置的尾部清潔。

### 3. 烹調中的鍋或平底鑊不穩定

請檢查：

- 鍋或平底鑊的底部是完全平坦的。
- 鍋或平底鑊置中在燃燒器內。
- 爐架沒有交換或擺放定位不正確。

### 4. 黃火

請檢查：

- 爐頭是否積聚油漬及污垢。請以暖水和洗潔劑清洗爐頭，然後抹乾並放好。

### 5. 有氣體異味

請檢查：

- 要關閉燃氣供應閥，離開現場才使用電話聯絡給你的供應商。

如果完成上述檢查後，故障依舊發生，請聯絡惠而浦售後服務。

## INSTALLATION INSTRUCTIONS

### Attention:

According to the Gas Safety Ordinance of Hong Kong, any gas installation works including the installation of appliances and connection tubing, must be undertaken by registered gas installers who are registered for that appropriate classes and be employed by registered gas contractors.

After unpacking the hob, make sure that it has not been damaged during transport. In the event of problems, contact the dealer or Whirlpool After-sales Service.

When installing built-in gas hob on top of stove cabinet, please check that there is provision for ventilation at the cabinet to ensure proper operation of the gas hob.

Do not store any flammable materials, sprays or pressurized containers inside the stove cabinet.

Gas connections must comply with local regulations.

- The manufacturer cannot be held responsible for any injury to persons or animals or damage to property arising from failure to comply with these requirements.

## TECHNICAL INFORMATION FOR THE INSTALLER

- Use protective gloves for handling, preparing and installing the product.
- Before installation, make sure that:
  - The local gas delivery conditions (nature and pressure) are compatible with the settings of the hob (see the rating plate mark on the gas hob);
  - The outer surfaces of the furniture or appliances adjacent to the hob are heat resistant according to local regulations;
  - This appliance is not connected to a fume exhaust device. It shall be installation regulations. Particular attention shall be given to the relevant requirements regarding ventilation;
  - Combustion products are discharged outdoors through specific hoods or wall and / or window mounted electrical fans.

## INSTALLATION ATTENTION

The gas cooking range must be installed by registered gas installer. Otherwise, Whirlpool (HK) Ltd. will not be responsible for any damages.

- Prior to installation, ensure that the appliance is adjusted for the type of gas with which it is to be supplied according to the local distribution conditions (nature of the gas and gas pressure).
- Install the built-in hob in a well ventilated room and keep it away from any combustible or inflammable objects such as paper or oil.
- Place the built-in hob on a stable and level surface.
- If the unit to be installed close to combustible surroundings (such as wooden walls, wooden shelves), it should be installed at least 150mm (6") from the side walls. The unit should be installed with a distance of at least 150mm away from surrounding combustible materials.
- At least keep 25mm (1") distance from bottom.
- External gas governor is not required.

## EXPLOSION HAZARD

- All gas supply connections must be tightened, when installing this product.
- After being tightened, all gas supply connections must be examined by soapy water to ensure no bubble and leakage.
- Failure to do so can result in death or fire.

## IMPORTANT SAFETY INSTRUCTIONS

## YOUR SAFETY AND THE SAFETY OF OTHERS ARE VERY IMPORTANT

This manual and the appliance itself provide important safety messages, to be read and observed at all times.

 This is the safety alert symbol, pertaining to safety, which alert users to potential hazards to themselves and others. All safety messages will follow the safety alert symbol and either the terms:

 **DANGER** Indicates a hazardous situation which, if not avoided, will cause serious injury.

 **WARNING** Indicates a hazardous situation which, if not avoided, could cause serious injury.

All Safety messages will tell you what the potential hazard is, tell you how to reduce the chance of injury, and tell you what can happen if the instructions are not followed.

 **WARNING** If the information in this manual is not followed exactly, a fire or explosion may result causing property damage or injury.

- Do not store or use gasoline or other flammable vapors and liquids in the vicinity of this appliance.

**What to do if you smell gas:**

- Do not try to light any appliance.
  - Do not touch any electrical switch.
  - Do not use any phone in your building.
  - Close the gas valve, leave the scene and then call your gas supplier.
  - If you cannot reach your gas supplier, call the police department.
  - Use appliance in well ventilated rooms only.
- This appliance has been designed for home use only.
  - Do not use this appliance as a space heater to heat or warm the room. Doing so may result in carbon monoxide poisoning and overheating of the hob. The Manufacturer declines all responsibility for inappropriate use or incorrect setting of the controls.
  - The appliance is not intended for use by persons ( including children) with reduced physical, sensory or mental capabilities, or with lack of experience and knowledge of the appliance, unless supervised or previously instructed in its use by those responsible for their safety.
  - Young children should be kept away from the appliance and be supervised to ensure that they do not play with it.
  - The use of a gas appliance produces heat and humidity in the room. Make sure the room is well-ventilated, or install an extractor hood with exhaust duct.
  - In case of prolonged use, additional ventilation may be necessary ( by opening a window or increasing the hood extraction speed ).
  - After use, make sure the knobs are in off position and close the main gas supply cock or the gas cylinder valve.
  - Overheated oils and fats may catch fire easily. Always remain vigilant when cooking foods rich in fat, oil or alcohol ( e.g. rum, cognac, wine ).
  - Keep the packaging materials out of the reach of children.
  - Before cleaning or maintenance, wait for hob to cool down.
  - This product is not intended to be installed and operated outdoors.
  - If the flame goes out accidentally, the safety device will cut off gas supply. Please try to light it again after at least 1 minute.
  - After ignition, make sure the burner ignites and flame stays even and normal.
  - Before removing cookware from the burner, always set burner to small flame or turn it off.
  - Do not use oversized or over weight cooking pot or receptacles. Or it will damage the grid and cause excessive heat to be reflected back onto the range surface. This may increase the temperature of this area and may cause damage.
  - Contact Whirlpool After-Sales Service for repair or parts replacement. During guarantee period, Whirlpool (HK) Ltd. will reserve the right to charge for spare parts and service fees if the damage is caused by misuse or improper installation.
  - Maximum load weight for this gas hob is 10kg.

## 技術規格

型號	GWG3010TH	GWG3010LH
氣體種類	香港煤氣	香港石油氣
額定熱負荷	6.0kW	5.0kW
工作壓力	1.5kPa	2.9kPa
電源供應	DC1.5V (D型乾電池)	
點火方式	脈衝點火	
安全裝置	熄火保護	
機身尺寸	(高)125mm(長)515mm(寬)290mm	

型號	GWG3020TH	GWG3020LH
氣體種類	香港煤氣	香港石油氣
額定熱負荷	(上) 2.5kW	(上) 1.8kW
	(下) 1.3kW	(下) 1.1kW
工作壓力	1.5kPa	2.9kPa
電源供應	DC1.5V (D型乾電池)	
點火方式	脈衝點火	
安全裝置	熄火保護	
機身尺寸	(高)115mm(長)515mm(寬)290mm	

## 售後服務

在致電售後服務前，確保您可提供以下信息：

機身編號 0000 000 00000



- 故障或問題的類型；
- 產品型號（編寫並貼在銘牌、保養咭上）；
- 機身編號可參照爐具下的銘牌上的機身旁邊的號碼或編寫並貼在指示、保養咭上。
- 您的完整地址和電話號碼。

如果有任何維修需要，請聯繫保養咭所示的授權售後服務。

## Table of Contents

<b>Important Safety Instructions</b>	12
<b>Installation Instructions</b>	13
<b>Cleaning Tips</b>	15
<b>Safeguarding The Environment</b>	16
<b>Product Description</b>	16
<b>Useful Advice For Using The Burners</b>	17
<b>How to Use The Hob</b>	17
<b>Troubleshooting Guide</b>	18
<b>Technical Specifications</b>	19
<b>After-sales Service</b>	20