

Whirlpool

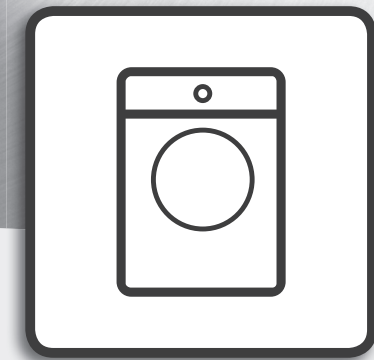

Instruction For Use
產品使用說明書

Model no: WWPU75210

產品型號 : WWPU75210



www.whirlpool.com.hk

ENGLISH 3

繁體中文 32

Please read the following instructions carefully before using the device, and keep this user manual for future reference.
為了您能更好地使用本產品，請您在使用前仔細閱讀此使用說明書，以發揮本機的最佳效能，並妥善保管好說明書。

USER MANUAL



THANK YOU FOR BUYING A WHIRLPOOL PRODUCT.

In order to receive a more complete assistance,
please register your appliance on www.whirlpool.com.hk

Index

Product Safety Rules

General Safety Rules	4-5
Environmental Conditions	6
Declaration of Conformity	7

Use and Care guide

Practical Tips	8
Maintenance and Cleaning	9
Quick User Guide	10
Controls	10-14
Table of programmes	15
Programmes	18
Drying Cycle	20
Automatic Washing/Drying Cycle	22
Troubleshooting and Warranty	23
Installation	26
Installation Diagram	31

General Safety Rules

Carefully read this manual for correct and safe appliance use and for helpful tips on efficient maintenance.



Only use the washing machine after carefully reading these instructions. We recommend you always keep this manual on hand and in good condition for any future owners.

Please check that the appliance is delivered with this instruction manual, warranty certificate, service centre address and energy efficiency label. Also check that plugs, drain hose support hook and liquid detergent or bleach tray (only on some models) are included. We recommend you keep all these components.

Each product is identified by a unique 16 - character code, also called the "serial number", printed on the sticker. This can be found inside the door opening. This code is a unique code for your product that you will need to register the product warranty, or if you need to contact the Customer Service Centre.

- This appliances is intended to be used in household and similar applications such as:
 - Staff kitchen areas in shops, offices and other working environments;
 - Farm houses;
 - By clients in hotels, motels and other residential type environments;

- Bed and breakfast type environments.
- Area for communal use in blocks of flats or in launderettes.
- A different use of this appliance from household environment or from typical housekeeping functions, as commercial use by expert or trained users, is excluded even in the above applications. If the appliance is used in a manner inconsistent with this it may reduce the life of the appliance and may void the manufacturer's warranty. Any damage to the appliance or other damage or loss arising through use that is not consistent with domestic or household use (even if located in a domestic or household environment) shall not be accepted by the manufacturer to the fullest extent permitted by law.
- Children should be supervised to ensure that they do not play with the appliance.
- Children of less than 3 years should be kept away unless continuously supervised.
- If the supply cord is damaged, it must be replaced by the manufacturer, its service agent or similarly qualified persons in order to avoid a hazard.
- Only use the hose-sets supplied with the appliance for the water supply connection (do not reuse old hose-sets).
- Water pressure must be between 0.05 MPa and 0.8 MPa.
- Make sure carpets or rugs do not obstruct the base or any of the ventilation openings.
- The OFF condition is reached by placing the reference mark on the programmes control/knob in the vertical position. Any other different position of such control sets the machine in ON condition (only for models with programmes knob).
- The final part of a washer dryer cycle occurs without heat (cool down cycle) to ensure that the items are left at a temperature that ensures that the items will not be damaged.

WARNING

- This appliance can be used by children aged from 8 years and above and persons with reduced physical, sensory or mental capabilities or lack of experience and knowledge if they have been given supervision or instruction concerning use of the appliance in a safe way and understand the hazards involved.
- Children shall not play with the appliance. Cleaning and user maintenance shall not be made by children without supervision.

 **WARNING**

never stop a washer dryer before the end of the drying cycle unless all items are quickly removed and spread out so that the heat is dissipated.

- This washer dryer must not be supplied through an external switching device, such as a timer, or connected to a circuit that is regularly switched on and off by a utility.
- This washer dryer is not intended to be operated by separate remote-control system.

Correct Use

After installation, the appliance must be positioned so that the plug is accessible.

- The appliance must not be installed behind a lockable door, a sliding door or a door with a hinge on the opposite side to that of the washer dryer, in such way that a full opening of the washer dryer door is restricted.
- The maximum load capacity of dry clothes depends on the model used (see control panel).
- The appliance is not to be used if industrial chemicals have been used for cleaning.
- Do not dry unwashed items in the washer dryer.
- Items that have been soiled with substances such as cooking oil, acetone, alcohol, petrol, kerosene, spot removers, turpentine, waxes and wax removers should be washed in hot water with an extra amount of detergent before being dried in the washer dryer.

- Items such as foam rubber (latex foam), shower caps, waterproof textiles, rubber backed articles and clothes or pillows fitted with foam rubber pads should not be dried in the washer dryer.

- Fabric softeners, or similar products, should be used as specified by the fabric softener instructions.

- Oil-affected items can ignite spontaneously, especially when exposed to heat sources such as a washer dryer. The items become warm, causing an oxidation reaction in the oil. Oxidation creates heat. If the heat cannot escape, items can become hot enough to catch fire. Piling, stacking or storing oil-affected items can prevent heat from escaping and so create a fire hazard.

- If it is unavoidable that fabrics contain vegetable or cooking oil or have been contaminated by hair care products be placed in a washer dryer they should first be washed in hot water with extra detergent - this will reduce, but not eliminate, the hazard.

- Remove all objects from pockets such as lighters and matches.

- To consult the product technical specification please refer to the manufacturer website.

Safety instructions

- Before cleaning or maintaining the washing machine, unplug the appliance and turn off the water tap.

 **WARNING**

water may reach very high temperatures during the wash cycle.

- Make sure there is no water in the drum before opening the door.
- Do not pull on the power cord or appliance to unplug the machine.
- Do not expose the washing machine to rain, direct sunlight or other weather elements. Protect from possible freezing.
- When moving, do not lift the washing machine by the knobs or detergent drawer; during transport, never rest the door on the trolley. We recommend two people lift the washing machine.
- In the event of fault and/or malfunction, turn off the washing machine, close the water tap and do not tamper with the appliance.

Immediately contact the Customer Service Centre and only use original spare parts. Failure to observe these instruction may jeopardise appliance safety.

Environmental Conditions



This appliance is marked according to the European directive 2012/19/EU on Waste Electrical and Electronic Equipment (WEEE).

WEEE contains both polluting substances (which can cause negative consequences for the environment) and basic components (which can be re-used). It is important to have WEEE subjected to specific treatments, in order to remove and dispose properly all pollutants, and recover and recycle all materials. Individuals can play an important role in ensuring that WEEE does not become an environmental issue; it is essential to follow some basic rules:

- WEEE should not be treated as household waste;
- WEEE should be handed over to the relevant collection points managed by the municipality or by registered companies.

In many countries, when you buy a new appliance, the old one may be returned to the retailer who has to collect it free of charge on a one-to-one basis, as long as the equipment is of equivalent type and has the same functions as the supplied equipment.

Declaration of Conformity

By placing the  mark on this product, we are confirming compliance to all relevant European safety, health and environmental requirements which are applicable in legislation for this product.

Practical Tips

Load tips

WARNING: when sorting laundry, make sure:

- have eliminated metallic objects such as hair clips, pins, coins, from laundry;
- to have buttoned pillow cases, closed zips, tied loose belts and long robe ribbons;
- to have removed rollers, hooks or clips from curtains;
- to have carefully read clothing washing labels;
- to have removed any persistent stains using specific detergents.
- When washing rugs, bedcovers or other heavy clothing, we recommend you avoid the spinning cycle.
- To wash wool, make sure the item can be machine washed and marked by the "Pure virgin wool" symbol with the "Does not mat" or "Machine washable" label.

Helpful suggestions for the user

A guide environmentally friendly and economic use of your appliance.

Maximise The Load Size

- Achieve the best use of energy, water, detergent and time by using the recommended maximum load size.

Save up to 50% energy by washing a full load instead of 2 half loads.

Do you need to pre-wash?

- For heavily soiled laundry only!

SAVE detergent, time, water and between 5 to 15% energy consumption by NOT selecting Prewash for slight to normally soiled laundry.

Is a hot wash required?

- Pretreat stains with stain remover or soak dried in stains in water before washing to reduce the necessity of a hot wash programme.

Save up to 50% energy by using a 60°C wash programme.

Before using a drying programme...

- SAVE energy and time by selecting a high spin speed to reduce the water content in laundry before using a drying programme.

Following is a **quick guide** with tips and recommendations on **detergent use at the various temperatures**. In any case, always read the instructions on the detergent for correct use and doses.

When washing heavily soiled whites, we recommend using cotton programs of 60°C or above and a normal washing powder (heavy duty) that contains bleaching agents that at medium/high temperatures provide excellent results.

For washes between 40°C and 60°C the type of detergent used needs to be appropriate for the type of fabric and level of soiling.

Normal powders are suitable for "white" or colour fast fabrics with high soiling, while liquid detergents or "colour protecting" powders are suitable for coloured fabrics with light levels of soiling.

For washing at temperatures below 40°C we recommend the use of liquid detergents or detergents specifically labeled as suitable for low temperature washing.

For washing **wool** or **silk**, only use detergents specifically formulated for these fabrics.

Maintenance and Cleaning

To clean the washing machine exterior, use a damp cloth, avoiding abrasives, alcohol and/or solvents. To maintain a good wash performance we recommend that the soap drawer and pump filters are regularly cleaned. A monthly service wash, using a proprietary cleaner is also recommended.

Drawer cleaning

- We recommend you clean the drawer to avoid accumulating detergent and additive residue.
- To do this, extract the drawer using slight force, clean it with running water and reinsert it in its housing.
- Ensure the siphon cap is correctly refitted.

Filter cleaning

- The washing machine comes with a special filter able to trap large residue, such as buttons or coins, which could clog the drain.
- Only available on certain models: pull out the corrugated hose, remove the stopper and drain the water into a container.
- Ensure all the water has been emptied from the drum.
- Before unscrewing the filter, we recommend you place an absorbent cloth under it to keep the floor dry. A small amount of water will come out of the filter as you remove it - this is normal.
- Turn the filter counter-clockwise to the limit stop.
- Remove and clean the filter; when finished, replace it turning it clockwise. The filter handle will be locked when it is not possible to turn any further and the handle is horizontal. Smearing a small amount of liquid soap on the filter seal will help refitting.
- Repeat the previous steps in reverse order to reassemble all parts.

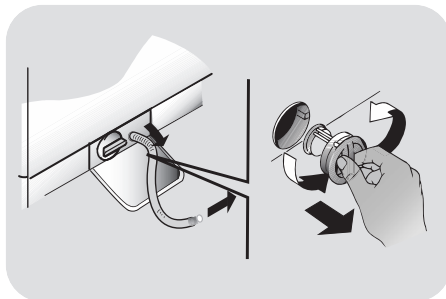

Suggestions for moves or prolonged disuse

- Should the washing machine be stored in an unheated room for a long period of time, drain all water from tubes.
- Unplug the washing machine.
- Detach the tube from the drainage system and clip on the rear of the machine and lower it, fully draining water into a bowl.
- Secure the drain tube with the drainage system and clip on the rear of the machine when finished.
- Keep the door glass and gasket clean.

Quick User Guide

This washing machine automatically adjusts the level of the water to the type and quantity of washing. This system gives a reduction in energy consumption and a saving in washing times.

Program selection

- Turn on the washing machine and select the required program.
- Adjust the washing temperature if necessary and press the required "option" buttons.

DRYING

If you would like the drying cycle to begin automatically after washing, select the programme required using the **DRYING SELECTION** button.

Or you can finish the wash and then select the drying programme and load size.

- Press the **START/PAUSE** button to start washing.
- At the end of the programme, the message "End" will appear on the display or, on some models, all wash stage indicator lights will turn on.

Wait until the DOOR LOCKED indicator light has gone out before opening the door.

- Turn off the washing machine.

For any type of wash, see the program table and follow the operating sequence as indicated.

Technical data

Water pressure:

min 0.05 Mpa / max 0.8 Mpa

0.05 MPa dispenses approximately 1 litre of water in 10 seconds)

Spin r.p.m.: See rating plate.

Power input / Power current fuse amp / Supply voltage: See rating plate.

Controls

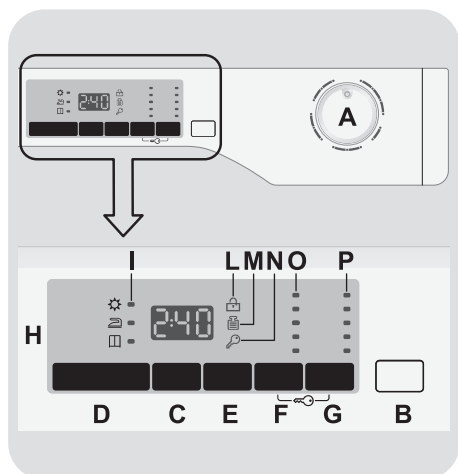

- A PROGRAMME selector with OFF position**
- B START/PAUSE button**
- C DELAY START button**
- D DRYING SELECTION button**
- E QUICK / STAIN LEVEL button**
- F TEMPERATURE SELECTION button**
- G SPIN SPEED button**
- F+G KEYLOCK**
- H Digital display**
- I DRYING SELECTION indicator lights**
- L DOOR LOCKED indicator light**
- M KG DETECTOR indicator light**
- N KEY LOCK indicator light**
- O TEMPERATURE SELECTION indicator lights**
- P SPIN SPEED indicator lights**

PROGRAMME selector with OFF position

When the programme selector is turned the display lights up to show the settings for the programme selected.

For energy saving, at the end of the cycle or with an inactivity period, the display level contrast will decrease.

N.B.: To switch the machine off, turn the programme selector to the OFF position.

- Press the **START/PAUSE** button to start the selected cycle.
- Once a programme is selected the **PROGRAMME** selector remains stationary on the selected programme till cycle ends.
- “End” will appear in the display at the end of the program and the DOOR LOCKED indicator light will go off, it is now possible to open the door.
- Switch off the washing machine indicator by turning the selector to **OFF**.

The PROGRAMME selector must be returned to the OFF position at the end of each cycle or when starting a subsequent wash cycle prior to the next programme being selected and started.

START / PAUSE button

Close the door BEFORE selecting the button START/PAUSE.

- Press to start the selected cycle.

When the START/PAUSE button has been pressed, the appliance can take few seconds before it starts working.

ADD OR REMOVE ITEMS AFTER THE PROGRAMMES HAS STARTED (PAUSE)

- Press and hold the **START/PAUSE** button for about **2 seconds** (some indicator lights and the time remaining indicator will flash, showing that the machine has been paused).
- Wait until the DOOR LOCKED indicator light has gone out before opening the door.

Before you open the door, please check water level is below the door opening to avoid flooding.

- After you have added or removed items, close the door and press the **START/PAUSE** button (the programme will start from where it left off).

CANCELLING THE PROGRAMME

- To cancel the programme, set the selector to the **OFF** position.
- Wait **2 minutes** until the safety device unlocks the door.

DELAY START button

- This button allows you to pre-programme the wash cycle to delay the start of the cycle for up to **24 hours**.
- To delay the start use the following procedure:
 - Select the required programme.
 - Press the delay start button once to activate it (**h00** appears on the display) and then press it again to set a **1 hour** delay (**h01** appears on the display). The pre-set delay increases by **1 hour** each time the button is pressed, until **h24** appears on the display, at which point pressing the button again will reset the delay start to zero.

- Confirm by pressing the **START/PAUSE** button. The delay countdown will begin and when it has finished the programme will start automatically.
- It is possible to cancel the delay start by turning the programme selector to **OFF**.

If there is any break in the power supply while the machine is operating, a special memory stores the selected programme and, when the power is restored, it continues where it left OFF.

The option buttons should be selected before pressing the **START/PAUSE** button. If an option is selected that is not compatible with the selected programme then the option indicator lights first flashes and then goes off.

DRYING SELECTION button

- **For automatic washing/drying cycle:** after the selection of washing programme according to laundry type, select a degree of dryness by pressing this button. At the end of the washing programme, the selected drying cycle will start automatically.

If a washing programme is not compatible with automatic drying selected, this function will not be activated.

If you exceed the maximum dryable load of laundry indicated in the programme table, the laundry may not be dried satisfactory.

- If you want delete the selection **before the programme starts**, please press repeatedly the button until the lights go off or reposition the programme selector to the **OFF** position.

- Drying only cycle:
select via the knob the desired drying programme in conjunction with your fabrics, by pressing this button it is possible to select a degree of dryness that is different to the default one (except for the wool drying programme).
- To cancel the cycle **during the drying phase**, please press the button for about **3 seconds**.



WARNING:

After cancelling the drying programme, the cool down phase will begin and please wait for about 10/20 minutes before opening the door.

- “End” will appear in the display at the end of the program and the **DOOR LOCKED** indicator light will go off, it is now possible to open the door.

It is also possible to cancel the drying cycle by turning the programme selector to the **OFF** position. It is necessary to wait for the cooling phase's end (10/20 minutes) and the **DOOR LOCKED** indicator light to go off before opening the door.

QUICK / STAIN LEVEL button

This button allows you to choose between two different options, depending on the selected programme.

- QUICK

The button becomes active when you select the **QUICK (14/30/44 Min.)** programme on the knob and allows you to select one of three durations indicated.

- STAIN LEVEL button

- Once the programme has been selected the wash time set for that programme will be automatically shown.
- This option allows you to choose between 3 levels of wash intensity modifying the length of the programme, depending on how much the fabrics are soiled (can only be used on some programmes as shown in the table of programmes).

TEMPERATURE SELECTION button

- This button allows you to change the temperature of the wash cycles.
- It is not possible to raise the temperature over the maximum allowed for the programme, in order to protect the fabrics.
- If you want carry out a cold wash all the indicators must be off.

SPIN SPEED button

- By pressing this button, it is possible to reduce the maximum speed, and if you wish, the spin cycle can be cancelled.
- If the label does not indicate specific information, it is possible to use the maximum spin expected in the program.

To prevent damage to the fabrics, it is not possible to increase the speed over the maximum allowed for the programme.

- To reactivate the spin cycle press the button until you reach the spin speed you would like to set.
- It is possible to modify the spin speed without pausing the machine.

An over dosing of detergent can cause excessive foaming. If the appliance detects the presence of excessive foam, it may exclude the spinning phase or extend the duration of the program and increase water consumption.

The machine is fitted with a special electronic device, which prevents the spin cycle should the load be unbalanced. This reduces the noise and vibration in the machine and so prolongs the life of your machine.

KEY LOCK

- Pressing simultaneously the buttons **TEMPERATURE SELECTION** and **SPIN SPEED** for about **3 seconds**, the machine allows you to lock the keys. In this way, you can avoid making accidental or unwanted changes if a button on the display is pressed accidentally during a cycle.
- The key lock can be simply cancelled by pressing the two buttons simultaneously again or turning off the appliance.

Digital Display

The display's indicator system allows you to be constantly informed about the status of the machine.

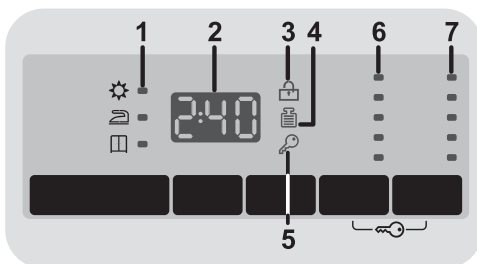
**1) DRYING SELECTION INDICATOR LIGHTS**

The indicators display the degrees of dryness that can be selected by the relevant button:

- ⚙️ **EXTRA DRY**
 (suitable for towels, bathrobes and bulky loads).
- 📄 **IRON DRY**
 (that leaves the laundry ready for ironing).
- 🗄️ **CUPBOARD DRY**
 (for items that will be put away without ironing).

2) CYCLE DURATION

- When a programme is selected the display automatically shows the typical cycle duration, which can vary, depending on the options selected.
- During the initial filling phase of the cycle the machine calculates the actual cycle time needed based on the load size, content and options selected. The real time of the wash will then be displayed. This time can recalculate during the wash depending on detergent levels and load balancing.

3) DOOR LOCKED INDICATOR LIGHT

- The indicator light is illuminated when the door is fully closed.

Close the door BEFORE selecting the START/PAUSE button.

- When **START/PAUSE** is pressed on the machine with the door closed, the indicator will flash momentarily and then illuminate.

If the door is not properly closed, the light will continue to flash for about 7 seconds, after which the start command will be automatically cancelled. In this case, close the door in the proper way and press the START/PAUSE button.

- Wait until **the DOOR LOCKED indicator light** has gone out before opening the door.

Kg LOAD INDICATOR LIGHT (function active only on certain programmes)

- During the first minutes of the cycle, the **“Kg LOAD”** indicator will remain on while the intelligent sensor will weigh the laundry and adjust the cycle time, water and electricity consumption accordingly.

- Through every wash phase **“Kg LOAD”** allows to monitor information on the wash load in the drum and in the first minutes of the wash it:

- adjusts the amount of water required;
- determines the length of the wash cycle;
- controls rinsing according to the type of fabric selected to be washed it;
- adjusts the rhythm of drum rotation for the type of fabric being washed;
- recognises the presence of too much soap suds, and if necessary, adjust the amount of rinse water.
- adjusts the spin speed according to the load, thus avoiding any imbalance.

5) KEY LOCK INDICATOR LIGHT

The indicator light show that the keys are locked.

6) WASH TEMPERATURE INDICATOR LIGHTS

This shows the washing temperature of the selected programme that can be changed (where allowed) by the relevant button.

If you want carry out a cold wash all the indicators must be off.



7) SPIN SPEED INDICATOR LIGHTS

This shows the spin speed of the selected programme, that can be reduced or omitted by the relevant button.

WWPU75210

Max. Spin Speed: 1200 rpm

Table of programmes

Max Load 7kg								Detergents and additives		
Programmes	Available temperatures	Max. spin speed (rpm)	Drying	Stain Level	Max. load for wash cycle (kg)	Max. load for dry- ing cycle (kg)	Default Duration (Minutes)	Prewash	Main	Softener
										
COTTON	Cold to 90°C	1200	✓	✓	7	5	2:49	-	●	○
COTTON +PREWASH	Cold to 60°C	1200	✓	✓	7	5	3:02	●	●	○
eCotton	Cold to 60°C	1200	✓	✓	7	5	3:21	-	●	○
Eco 20°	Cold to 20°C	1000	-	-	7	5	1:36	-	●	○
MIXED	Cold to 60°C	1000	✓	-	3.5	-	1:55	-	●	○
DECLICATES	Cold to 40°C	400	-	-	2.5	-	0:54	-	●	○
RINSE	-	1000	-	-	-	-	0:28	-	-	○
SPIN	-	1000	-	-	-	-	0:10	-	-	-
DRAIN	-	-	-	-	-	-	0:04	-	-	-
QUICK 14'	Cold to 30°C	1000	-	-	1	-	0:14	-	●	○
QUICK 30'	Cold to 30°C	1000	-	-	2.5	-	0:30	-	●	○
QUICK 44'	Cold to 30°C	1000	-	-	3.5	-	0:44	-	●	○
SHIRTS	Cold to 30°C	1000	-	✓	3.5	-	1:15	-	●	○
WOOL	Cold to 40°C	800	-	-	1	-	0:48	-	●	○
HANDWASH	Cold to 30°C	800	-	-	1	-	0:48	-	●	○
SYNTHETICS DRY	-	-	-	-	3.5	-	2:50	-	-	-
COTTON DRY	-	-	-	-	5	-	3:50	-	-	-

● Required quantity ○ Optional quantity

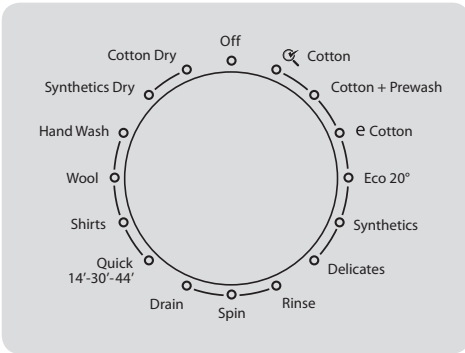

Please read these notes:

- * Maximum load capacity of dry clothes, according to the model used (see control panel).
- When a programme is selected, on the display is shown the recommended wash temperature that can be reduced (where allowed) by the relevant button.
- For the programmes shown you can adjust the duration and intensity of the wash using the STAIN LEVEL button.
- Selecting the QUICK program on the knob, it will be possible to select with the QUICK button, one of the three QUICK programs available among 14', 30' and 44'.
- Programmes for automatic drying.

INFORMATION FOR THE TEST LABORATORIES (Ref. EN 50229 Standards)

Washing

Use the programme ** with the maximum degree of soiling selected, maximum spin speed and a temperature of 60°C. Programme recommended also for test with a lower temperature.

Drying

First drying with A kg (a load consist: pillowcases and hand-towels) selecting the cotton drying programme (Cotton Dry) cupboard dry ().

Second drying with B kg (a load consist: sheets and hand towels) selecting the cotton drying programme (Cotton Dry) cupboard dry ().

Capacity (washing) (kg)	A (kg)	B (kg)
	First drying	Second drying
7	5	2

Programmes

Programmes selection

To clean different types of fabrics and various levels of dirt, the washing machine has specific programs to meet every need of washing (see table of programmes).

WASHING

Cotton

An intensive wash. The final spin at maximum speed gives more efficient removal.

Cotton + Prewash

This programme has been designed to remove the stronger stains from cotton white clothes. The prewash guarantees the tough dirt removal. Add into compartment "1" a quantity of detergent equal to 20% of that used for main wash.

e Cotton

This program is suitable to clean normally soiled cotton laundry and it is the most efficient program in terms of combined energy and water consumptions for washing cotton laundry.

Eco 20°

This innovative programme, allows you to wash different fabrics and colours together, such as cottons, synthetics and mixed fabrics at only 20°C and provides an excellent cleaning performance. Consumption on this program is about 40% of a conventional 40°C cottons wash.

Mixed

The washing and rinsing optimise the speed and rhythm of the drum action and water levels. The gentle spin, ensures a reduced formation of creases in the fabric.

Delicates

This program has reduced periods of drum rotation during the cycle and is particularly.

Rinse

This program performs 3 rinses with an intermediate spin (which can be reduced or excluded by using the appropriate button). It is used for rinsing any type of fabric, for example after a wash carried out by hand.

Spin

The programme carries out a maximum spin. It is possible to delete or reduce the spin with the **SPIN SPEED** button.

Drain

This programme drains out the water.

QUICK (14/30/44 Min.)

Washing cycle suggested for low loads and slightly dirty. With this program it is recommended to reduce the quantity of detergent normally used, in order to avoid unnecessary waste. Selecting the QUICK program and acting on the button you can choose one of three programs available.

Shirts

The washing cycle is optimized to reduce the creation of creases, keeping an excellent washing performance. It is also possible to further reduce the spin speed, to ensure an easier ironing.

Wool

This program performs a wash cycle dedicated to the wool fabrics that can be washed in a washing machine, or the articles to be washed by hand.

Hand Wash

Program for hand wash only clothes, the program ends with 3 rinses and a slow spin, suitable for washing delicate fabrics. The wash cycle and rinses are carried out with a high level of water to ensure the best performance.

DRYING



WARNING:

Dispensers used for concentrated powders and liquid detergents must be removed from the drum before commencing the tumble drying programmes.

The drum changes direction during the drying cycle to prevent the laundry from tangling and producing even more drying.

Cool air is used during the last 10/20 minutes of the drying cycle to minimize creasing.

Synthetics (Low Heat)

Low temperature drying programme recommended for synthetics and mixed fibres (always refer to the laundry care label).

Cottons (High Heat)

High temperature drying programme recommended for cottons and linen items (always refer to the laundry care label).

Drying Cycle

- Drying guidance advice is general, but practical experience of using the product will help you to achieve the best drying results.
- We recommend setting a lower drying time than indicated, when first using the appliance in order to establish the degree of dryness required.
- We recommend not drying fabrics that fray easily, such as rugs or garments with a deep pile, in order to avoid air duct clogging.
- We recommend that you sort the laundry by the following methods:
 - **By drying care symbols, which are displayed on the clothing labels**

- Suitable for tumble drying.
- Tumble dry at high temperature.
- Tumble dry at low temperature only.
- DO NOT** tumble dry.

If the fabric does not have a care label, you should assume that it is not suitable for drying.

- By size and thickness

Whenever the wash load is bigger than the drying capacity, separate the clothes according to thickness (e.g. towels from thin underwear).

- By fabric type

Cottons/linen: towels, cotton jersey, bed and table linen.

Synthetics: blouses, shirts, overalls, etc. made of polyester or polyamide, as well as for cotton/synthetic mixes.

- Only dry pre-spun laundry.

The correct way to dry

- Open the door.
- Fill with the laundry, not exceeding the maximum drying load indicated in the programme table. For large items (e.g. sheets) or very absorbent items (e.g. towels or jeans), it is a good idea to reduce the load.
- Close the door.
- Turn the programme dial to the more suitable drying programme for your laundry.
- The washer dryer can perform the following types of drying:
 - **Low temperature** drying programme recommended for mixed fabrics (synthetics/cotton) synthetic fabrics (Synthetics Dry symbol on programme dial).
 - **High temperature** drying programme recommended for cotton, terry toweling, linen, hemp fabrics, etc... (Cotton Dry symbol on programme dial).
- Select the degree of dryness that you require:

 **EXTRA DRY**
(suitable for towels, bathrobes and bulky loads).

 **IRON DRY**
(that leaves the laundry ready for ironing).

 **CUPBOARD DRY**
(for items that will be put away without ironing).

- The washer dryer will calculate the time needed for drying and the level of moisture remaining in the laundry, according to the load and drying type selected.
- Check that the tap is turned on and that the discharge hose is positioned correctly.



WARNING:

Do not dry woollen garments or articles with special padding (e.g. quilts, quilted anoraks, etc.) and very delicate fabrics. If garments are drip/dry, load less items as to prevent creasing.

- Press the **START/PAUSE** button (the display will show the drying time remaining).

The appliance calculates the time to the end of the selected programme based upon a standard loading. During the cycle, the appliance corrects the time according to the size and composition of the load.

During the drying phase the drum will accelerate to a higher speed to distribute the load and to optimize the drying performance.

- When the programme is finished the word **"End"** will appear on the display. After **5 minutes** the appliance will go into standby mode (on certain models, the display will show two lines).
- Switch off the machine by turning the programme selector to the **OFF** position.

- Open the door and remove the laundry.
- Turn off the tap.

CANCELLING THE DRYING PROGRAMME

- To cancel the drying programme, press and hold the **DRYING SELECTION** button for about **3 seconds**.



WARNING:

After cancelling the drying programme, the cool down phase will begin and you must wait for about 10/20 minutes before opening the door.

In order to ensure the correct operation of the appliance, it is advisable not to interrupt the drying phase unless it is absolutely necessary.

Automatic Washing/Drying Cycle

You cannot exceed the maximum dryable load of laundry indicated in the programme table, otherwise the laundry will not be dried satisfactory.

- Washing

- Open the drawer and put in the correct amount of detergent.
- Refer to the list of washing programmes for the fabrics to be washed (e.g. very dirty cotton) and turn the selector knob to the required programme.
- Adjust the wash temperature if necessary.
- Press the option buttons (if required).
- Check that the tap is turned on and that the discharge hose is positioned correctly.

- Drying

- Select the degree of dryness that you require:

 **EXTRA DRY**
(suitable for towels, bathrobes and bulky loads).

 **IRON DRY**
(that leaves the laundry ready for ironing).

 **CUPBOARD DRY**
(for items that will be put away without ironing).

- Press the **START/PAUSE** button.
- At the end of the wash phase the display will show the drying time remaining.

- When the programme is finished the word **"End"** will appear on the display. After **5 minutes** the appliance will go into standby mode (on certain models, the display will show two lines).
- Switch off the machine by turning the programme selector to the **OFF** position.
- Open the door and remove the laundry.
- Turn off the tap.

CANCELLING THE DRYING PROGRAMME

- To cancel the drying programme, press and hold the **DRYING SELECTION** button for about **3 seconds**.



WARNING:

After cancelling the drying programme, the cool down phase will begin and you must wait for about 10/20 minutes before opening the door.

In order to ensure the correct operation of the appliance, it is advisable not to interrupt the drying phase unless it is absolutely necessary.

Troubleshooting and Warranty

If you believe the washing machine is not working correctly, consult the quick guide provided below which includes some practical tips on how to fix the most common problems.

ERROR CODE FORMAT

- **Models with a display:** the error is shown by a number preceded by the letter “E” (example: E2 = Error 2).
- **Models without display:** an error is shown by a sequence of flashes of every LED. The error code is shown by the number of flashes followed by a pause of 5 seconds (example: two flashes – pause 5 seconds – two flashes – repeating = Error 2).

Error Shown	Possible causes and practical solutions
E2 (with display) 2 flashes of the LEDs (without display)	The machine cannot load water.
	Make sure the water supply tap is open.
	Make sure the water supply hose isn't bent, kinked or trapped.
	Make sure the drain pipe is at the proper height (see installation section).
E3 (with display) 3 flashes of the LEDs (without display)	Close the water supply tap, unscrew the filler hose from the back of the washing machine and make sure the “anti-sand” filter is clean and not blocked.
	The washing machine does not drain water.
	Make sure the filter is not clogged.
E4 (with display) 4 flashes of the LEDs (without display)	Make sure the drain hose isn't bent, kinked or trapped.
	Make sure the home drainage system is not blocked and is allowing water to flow through without obstruction. Try to drain the water in the sink.
	There is too much foam and/or water.
E7 (with display) 7 flashes of the LEDs (without display)	Ensure the correct amount of detergent is being used and the detergent is designed for use in a washing machine.
	Door problem.
	Make sure the door is correctly closed.
Any other code	Make sure the clothes inside the drum are not preventing the door from closing fully.
	If the door is locked, turn off and unplug the washing machine from the electrical supply socket, wait 2-3 minutes and reopen the door.
	Turn off and unplug the washing machine, wait a minute. Turn on the machine and restart a program. If the error occurs again contact an Authorised Customer Service Centre directly.

OTHER ANOMALIES

Problem	Possible causes and practical solutions
The washing machine does not work / start	Make sure the product is plugged into a working supply socket.
	Make sure power is on.
	Make sure the wall socket is working, testing it with another appliance such as a lamp.
	The door may not be correctly closed: open and close it again.
	Check whether the required program was correctly selected and the start button pressed.
	Make sure the washing machine is not in pause or time delay mode.
Water leaked on the floor near the washing machine	This may be due to a leak from the seal between the tap, supply hose and fill valve; in this case, replace it and tighten the hose connections correctly.
The washing machine does not spin	Make sure the front filter is correctly closed.
	The machine is fitted with a detection system that protects the load and product from damage if the load is not balanced before spinning. This may result in:- <ul style="list-style-type: none"> • The machine attempts to balance the load, increasing the time of spin. • Reduction of the speed of spin to decrease vibrations and noise. • The spin cycle aborting to protect the machine and load. If this is experienced remove the load de-tangle it, reload it and restart the spin program.
	This could be due to the fact that water has not been completely drained: wait a few minutes. If the problem persists, see "Error 3" section.
	Some models include a "no spin" function: make sure it is not selected.
	Check which options are selected and their effect on the spin cycle.
	Excessive detergent can impede the spin cycle, ensure the correct amount of detergent is being used.
Strong vibrations / noises are heard during the spin cycle	The washing machine may not be fully levelled: if necessary, adjust the feet as indicated in the specific section.
	Make sure transport screws, rubber bungs and spacer tubes were removed.
	Make sure there are no foreign objects inside the drum (coins, hinges, buttons, etc...).

The standard manufacturer warranty covers faults caused by electrical or mechanical faults in the product due to an act or omission of the manufacturer. If a fault is found to be caused by factors outside the product supplied, miss-use or as a result of the instructions on use not being followed, a charge may be applied.

The use of ecological detergents without phosphates may cause the following effects:

- cloudier rinse drain water:

This effect is tied to the suspended zeolites which do not have negative effects on rinse efficiency.

- white powder (zeolites) on laundry at the end of the wash:

this is normal, the powder is not absorbed by fabric and does not change its colour.

To remove the zeolites, select a rinse programme. In the future consider using slightly less detergent.

- foam in the water at last rinse:

This does not necessary indicate poor rinsing. Consider using less detergent in future washes.

- abundant foam:

This is often due to the anionic surfactants found in the detergents which are hard to eliminate from laundry.

In this case, do not re-rinse to eliminate these effects: it will not help at all.

We suggest conducting a maintenance wash using a proprietary cleaner.

If the problem persists or if you suspect a malfunction, immediately contact an Authorised Customer Service Centre.

It is always recommended to use original spare parts, that are available at our Authorised Customer Service Centres.

Warranty

The product is guaranteed under the terms and conditions stated on the certificate included with the product. The warranty certificate must be duly filled in and stored, so as to be shown to the Authorised Customer Service Centre in case of need. Proof of purchase must be made available at the time of any warranty related repair.

The manufacturer declines all responsibility for any printing errors in the booklet included with this product. Moreover, it also reserves the right to make any changes deemed useful to its products without changing their essential characteristics.

Installation

- Release the power chord and drain hose from the securing clip at the rear of the machine.
- Remove the **2** or **4** transportation screws (**A**) on the back and remove the **2** or **4** flat washers, rubber bungs and plastic spacer tubes (**B**) as illustrated in **figure 1**.
- If the washing machine is built-in, unscrew the **3** or **4** transportation screws (**A**) and remove the **3** or **4** flat washers, rubber bungs and plastic spacer tubes (**B**).
- During the removal of the screws occasionally spacer tubes fall inside the product, these can be removed by tilting the product forward and recovering them from the floor or inside the base of the machine.
- Cover the open transportation screw holes with the **2** or **4** plastic caps included in the instruction bag.



WARNING

keep packaging materials away from children.

Place the corrugated plastic sheet, found on top of the appliance during the unpacking process, into the base of the appliance as shown in **figure 2** (according to the model, consider version **A**, **B** or **C**).

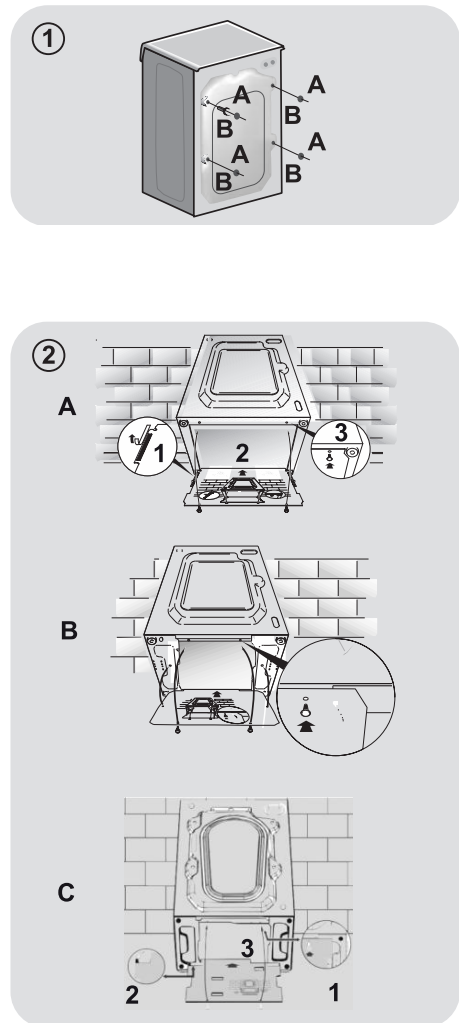

Fitting under worktop

- Slide the washer into an opening of the size indicated in the diagram opposite.

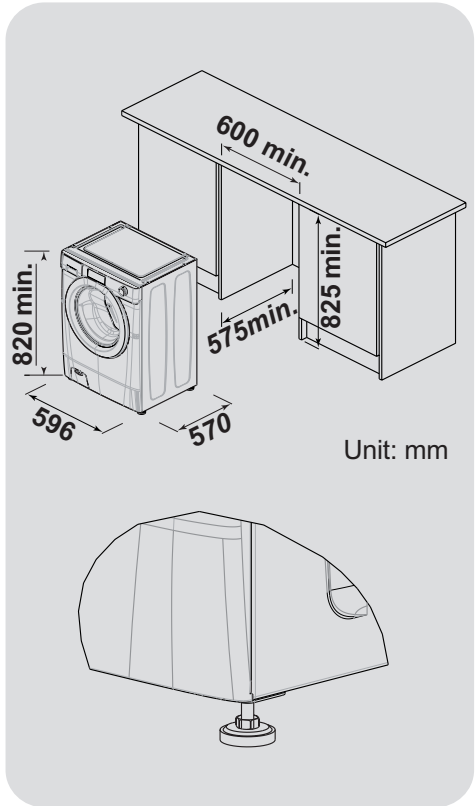

- The 4 adjustable feet allow the height of the washer to be adjusted from 820 mm to a maximum of 840 mm. To adjust the height, you should remove the nuts fitted to each foot and replace these with the 5 mm nuts supplied. Raise the feet to your desired height and then fully tighten the lock nut to the base of the washer.

Hydraulic connections

- Connect the water hose to the water supply tap (**fig. 3**) only using the hose supplied with the appliance (do not reuse old hose-sets).

- SOME MODELS** may include one or more of the following features:

- HOT&COLD (fig. 4):**

water mains connection settings with hot and cold water for higher energy savings. Connect the grey tube to the cold water tap  and the red one to the hot water tap. The machine can be connected to the cold water tap only: in this case, some programs may start a few minutes later.

- AQUASTOP (fig. 5):**

a device located on the supply tube that stops water flow if the tube deteriorates; in this case, a red mark will appear in the window "A" and the tube must be replaced. To unscrew the nut, press the one-way lock device "B".

- AQUAPROTECT – SUPPLY TUBE WITH GUARD (fig. 6):**

Should water leak from the primary internal tube "A", the transparent containment sheath "B" will contain water to permit the washing cycle to complete. At the end of the cycle, contact the Customer Service Centre to replace the supply tube.

Setting

- The washing machine should be installed in its final position such that the water fill hose is not kinked or trapped. The corrugated drain hose should be inserted into suitable drain pipe of between 50 cm and 85 cm height above the floor using the curved drain hose support. If an under sink connection is used the drain hose must be routed above the sink overflow opening to prevent back siphoning. Care must be taken to avoid kinking or trapping the drain hose (**fig. 7**).

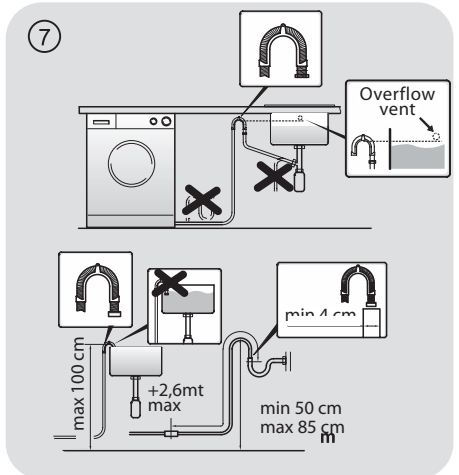
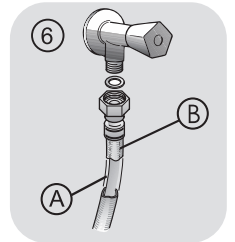
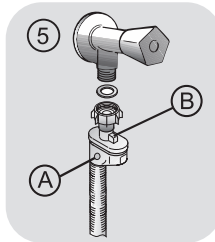
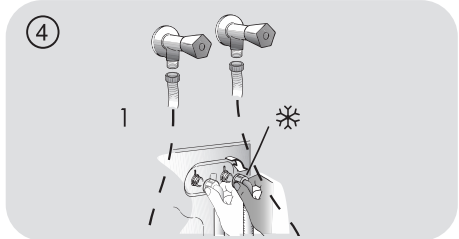
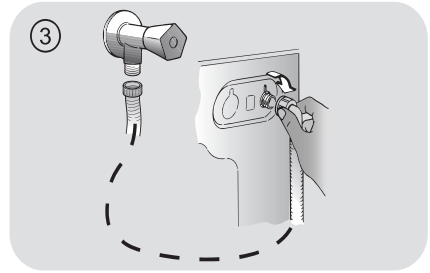

- Level the appliance using the feet as illustrated in **figure 8**:
 - a. turn the nut clockwise to release the screw;
 - b. rotate the foot to raise or lower it until it touches the floor;
 - c. lock the foot, screwing in the nut, until it tightens against to the bottom of the washing machine.
- Plug in the appliance.



WARNING:
contact the Customer Service Centre should the power cord need replacement.

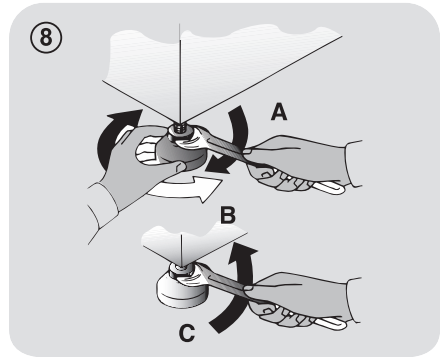

Detergent drawer

The detergent draw is split into 3 compartments as illustrated in **figure 9**:

- compartment "1": for prewash detergent;
- compartment : for special additives, softeners, starch fragrances, etc.;



WARNING:
only use liquid products; the washing machine is set to automatically dose additives at each cycle during the last rinse.

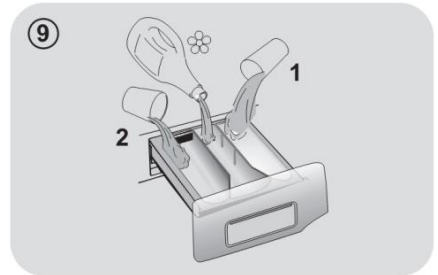

- compartment "2": for washing detergent.



WARNING:
some detergents are hard to remove. In this case we recommend using the specific container to be placed in the drum (example in figure 10).

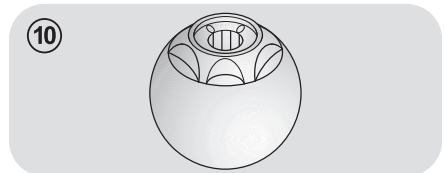

Installation Diagram

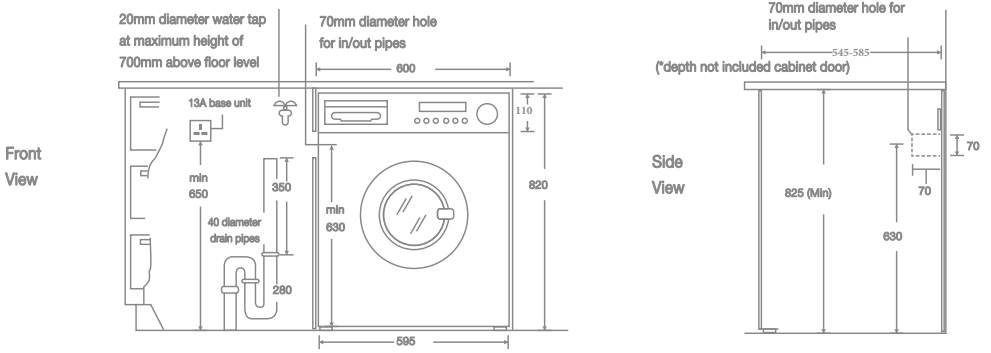

繁體中文

產品安全指引、使用說明及安裝指南



感謝您購買惠而浦產品
為了獲得更完善的服務，
請於www.whirlpool.com.hk註冊您的產品

索引

產品安全指引

一般安全指引	33
環境保護	35
安全聲明	36

使用說明

使用提示及應用	37
維修和清潔	38
快速啟動操作	39
控制說明	39

程序表

程序	47
乾衣程序	49
自動洗衣/乾衣操作	51
故障排除及日常保養	52

安裝指南

安裝簡圖	60
------------	----

一般安全指引

請仔細閱讀本手冊，以正確和安全地使用洗衣乾衣機，並提供有效的保養及維護提示。

 這是提醒您閱讀本手冊的符號。

使用洗衣乾衣機前請先細閱〈一般安全指引〉。我們建議您隨時保留本手冊，並將手冊保持良好狀態，以便保留予將來使用。

請檢查本產品是否附有使用說明書，保養登記卡，服務中心地址和能源標籤。還要檢查是否包括插頭，排水喉支架和洗衣液或漂白盒(只適用於指定型號產品)。我們建議您保留所有這些組件。

每個產品都有一組獨立的符號代碼，由16個符號數字組成，以示識別，也稱為“序號”，印在銘牌上。這可以在機門內的找到。此代碼是您的產品的唯一代碼，您需要註冊產品，或者您需要聯繫售後服務中心，以確保適當的維修保養。

本產品設計只適用於家居或下列之類似環境：

- 一般商店、辦公室及其他工作環境的職員專用廚房；
- 農莊；

- 供入住酒店、汽車旅館及其他住宅式旅店之顧客使用；
- 提供簡單住宿及早餐服務之旅舍。
- 此洗衣乾衣機不適用於商業用途，如公共洗衣房/公共平台或公寓內使用。
 - 即使在上述環境下，本產品亦只適合作家居或一般酒店房間管理的操作目的(包括由專家或有經驗用作商業用途)，而不適合作任何其他用途。
 - 假如本產品在不符以上描述的條件下進行操作，產品的壽命有可能因而縮短，同時產品之保養服務將會失效。

警告

- 任何因為不符合家居操作用途(即使本產品被安置於家居環境中)，導致產品本身損壞或造成其他傷害或毀壞，本製造商將根據法律授予的一切權利，不承擔任何相關責任。
- 洗衣乾衣機可由8歲以上之兒童及身體，感官或精神障礙或經驗知識不足的人士操作，前提是此等人士已接受洗衣乾衣機的安全指導及指引，且瞭解使用洗衣乾衣機的相關危險。
- 兒童不可胡亂玩弄洗衣乾衣機。未經指導及指引，且瞭解使用洗衣乾衣機的相關危險。兒童不可進行洗衣乾衣機的清潔及保養工作。
- 兒童需要得到監視，以確保他們不可玩弄洗衣乾衣機
- 除非得到持續監視，否則幼兒(0-3歲)應遠離洗衣乾衣機。
- 如果電源線損壞，必須根據相同產品更換電源線。電源線只能由符合製造商指導和現行的安全法規合格的技術人員更換。
- 只能使用本產品隨附的新水喉將洗衣乾衣機連接到水源(舊有的水喉絕對不能重用)。
- 水壓必須於0.05-0.8MPa內。
- 確保地毯或其他材料不會阻塞洗衣乾衣機底部的通風孔。
- 將「程序」旋鈕上的標記旋轉至向上「OFF」的位置，以表示處於關閉狀態。(只適用於有「程序」旋鈕的型號)
- 乾衣程序的最後一個階段是無熱(冷卻階段)，以確保衣物保持在一個溫度水平而不導致衣物損壞。

警告

除非迅速地取出所有衣物並攤開散熱，否則於乾衣程序結束之前，請勿停止洗衣乾衣機。

正確使用

- 安裝完成後，必須將洗衣乾衣機定位，使電源插座易於處理。
- 此洗衣乾衣機的安裝位置必須能夠讓機門被完全打開(不能被例如背面的門，滑動門，或者是在側面門鉸阻礙)。
- 乾衣的最大負載能量，是取決於所使用的型號(詳細請參閱〈程序表〉篇章)。
- 此洗衣乾衣機不得使用工業化學品進行清潔。
- 不要在洗衣乾衣機中乾洗，未經清洗的衣服。
- 物品沾了如烹調油、丙酮、乙醇、汽油、煤油、除斑、松節油、蠟物質和除蠟劑應在放入洗衣乾衣機烘乾之前，先以額外洗衣劑並用熱水清洗。
- 物品如泡沫橡膠(膠乳泡沫)、淋浴帽、防水織物、橡膠備份製品和衣服或裝有泡沫橡膠墊的枕頭不應放入洗衣乾衣機進行烘乾。

警告

- 此洗衣乾衣機不能透過外置控制器(如時間控制器)或連接定時開關線路上操作。
- 此洗衣乾衣機不能透過遙控裝置進行操作。
- 衣物柔順劑或類似產品應按照柔順劑產品內的說明使用。
- 浸油物品易燃，特別當受熱時，如接觸到洗衣乾衣機，物品變得溫暖，導致油份產生氧化反應。氧化產生熱量，如果不能散熱，該物品過熱而足以起火。擁擠，堆放或儲存油浸泡過的物品可以阻礙熱量散失，因此引起火災。
- 如果在不可避免的情況下，衣物含有植物油或食用油，或被頭髮護理產品污染。應在放入洗衣乾衣機烘乾之前，先以額外洗衣劑並用熱水清洗。
- 此可減少對洗衣乾衣機的損壞，但不能消除。
- 移除衣物袋子內所有物品如打火機，火柴等。
- 要查詢產品的技術規格，請參考製造商的網站。

安全守則

- 執行任何維修或清潔操作之前，請先拔下電源插頭及關閉水龍頭。
- 確保電源依法連接接地線。否則，尋求合格的技术人員協助。
- 請勿使用轉換器，多頭插座或延長線。

注意

在洗衣程序期間，水溫可能達到非常高的溫度。

- 開機門前，檢查清查洗衣桶內沒有積水。
- 切勿拉扯電源線或拔下電源插頭。
- 切勿將本產品放置於露天環境下(包括會被雨淋、太陽直射等地方)。並防止凍結。
- 在移動洗衣乾衣機時，請勿使用旋鈕或洗衣劑盒提起洗衣乾衣機；在運輸過程中，請勿將機門躺於手推車上。此洗衣乾衣機建議由兩個或更多的人進行安裝處理。
- 在發生故障和/或故障的情況下，請關閉洗衣乾衣機，關閉水龍頭及請勿玩弄洗衣乾衣機。

請使用我們授權的售後服務中心，及使用原廠零售配件，不遵守此說明，可能會損害洗衣乾衣機的安全。

環境保護

 本產品附有的標誌，表示符合歐盟就廢電子電機產品發出的2012/19/EU指令。

廢電子電機產品包含污染物質及可再使用成份。為了去除當中所有污染物、修復及循環有用物料，它們必須經過特別的處理方法。透過以下適當方法棄置本產品，閣下便可避免以不恰當的方法棄置本產品，從而幫助減少對環境和人類健康造成的不良影響：

- 廢電子電機產品不可視作一般家居廢物般棄置。
- 廢電子電機產品需要送往特定的收集點，以便按照當地的相關廢物處理條例，進行合適的回收處理工作。

現有不少國家都有推廣回收政策，當消費者於購買新家電時都可選擇把舊電器免費回收給零售商，只要該舊電器是與新品為同類型及持同等功能便可。

安全聲明

本產品標有的“CE”商標，
確認已符合所有歐洲安全，
健康及環境標準的相關法
例。

使用提示及應用

加載小貼士

⚠ 警告：分類洗衣時，請確保：

- 從衣物中去除髮夾，別針，硬幣等金屬物體；
- 釦緊枕頭套，封閉所有拉鍊，捆紮鬆綁帶和長袍絲帶；
- 從窗簾中取出滾輪，鉤子或窗簾夾；
- 仔細閱讀衣料類型 / 護理標籤符號；
- 使用特定的洗衣劑去除任何污固的污漬。
 - 當清洗地毯，床單或其他大件的衣物時，我們建議您避免使用脫水程序。
 - 如要清洗羊毛衣物，請確保該衣物可於此洗衣乾衣機進行清洗，及標明為「羊毛」，同時標明「防皺褶」或「可機洗」。

給使用者的有用建議

以下的指導可助閣下在使用家庭電器時，獲得最具環保效益和經濟成效。

每次以全機衣量進行洗衣操作

- 為達到最佳的能源效益，耗水，洗衣劑用量及洗衣時間，我們建議您一次過清洗建議最大的洗衣量。

以進行一次洗衣操作，比較以一半洗衣量的分兩次進行洗衣操作，可節省高達 50% 耗電量。

什麼情況下才真正需要進行預洗？

- 適用嚴重污染的衣物！可節省洗衣劑，時間，水，及能源消耗 5 至 15%，對於輕微到正常污染的衣物，均不需選擇預洗方式。

您需要熱水洗嗎？

- 在進行機洗衣前先用除污劑處理衣物或在水中浸泡污漬，以減少使用熱洗程序進行洗衣的需要，使用攝氏 60 度洗衣比較攝氏 90 度洗衣，可節省多達 50% 耗電量。

使用乾衣程序之前：

在使用乾衣程序之前，通過選擇高旋轉速度來節省能源和時間，以減少衣物中的含水量。

以下是快速指南提示以及關於各種溫度下洗衣劑的使用建議。在任何情況下，請務必閱讀洗衣劑上的說明，以正確使用和確保適當使用劑量。

當清洗非常骯髒的白色衣物時，我們建議使用攝氏60度或以上的棉質洗衣程序，配合能在中溫/高溫使用並含有漂白成份的普通洗衣粉，能令洗衣效果更佳。

在攝氏40度至60度的洗衣溫度下，選擇洗衣劑時需因應衣物物料和衣物骯髒程度。

普通洗衣粉適用於清洗較骯髒的白色衣物和不易染色的衣物，而洗衣液或護色洗衣粉適用於清洗一般骯髒而易染色的衣物。

在攝氏 40 度以下的洗衣溫度下，我們建議使用專為較低洗衣溫度而設的洗衣液或洗衣劑。

清洗羊毛或絲質物料時，需使用適合清洗該物料的洗衣劑。

維修和清潔

要清潔洗衣乾衣機外部，請使用濕布，避免使用含有酒精成份的沙布及/或稀釋劑。為了保持良好的洗滌性能，我們建議定期清潔洗衣劑格和過濾器。當您清洗本產品時，建議使用專有清潔劑進行清洗。

清潔洗衣劑格

- 我們建議您清潔洗衣劑格，以避免積聚洗衣劑和添加劑殘留物。
- 用輕微的力抽出洗衣劑格，用清水清洗，並重新推回洗衣劑盒格內。
- 確保洗衣劑盒正確地放回。

清潔過濾器

- 本洗衣乾衣機設有專用的過濾器，作用是阻隔一些體積較大、容易造成排水管淤塞之沉澱物或雜物(如硬幣、衣鈕等)，同時方便取走該些沉澱物或雜物。
- 只適用於某些型號：拉出喉管，取下塞子並將水排入容器。
- 確保清空滾桶中的所有水份。
- 取出過濾器之前，請先將一條吸水力強的毛巾放置於過濾器下方，以便吸走可能積存在排水泵內的少量積水。當您移除它時，少量的水將從過濾器中出來 - 這是正常現象。
- 然後按逆時針方向打開抽出。

- 插入濾網塞並裝回底座：將濾網塞回原位，然後按順時針方向轉緊到最深位置。當無法進一步旋轉時，過濾器手柄將被鎖定，濾網手柄必須處於水平的位置，在過濾器密封上塗抹少量洗手液，將有助於旋轉濾網塞。
- 以相反的順序重複上述步驟，以重新組裝所有部件。

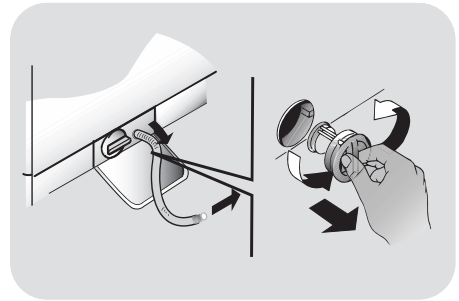

洗衣機如需搬遷或長期間置

假如洗衣乾衣機需要搬遷或將長期間置於溫度較低的地方，必需先將洗衣乾衣機所有喉管的積水完全排走。

- 拔除洗衣乾衣機電源插頭。
- 讓喉管垂下並置於盤內，直至所有水被排出。
- 完成後，將排水管與排水系統和夾子固定在機器的後部。
- 保持機門玻璃和橡膠密封圈清潔。

快速啟動操作

洗衣乾衣機會根據洗衣類型和數量而自動調節水位。該系統減低能源消耗，節省洗衣時間。

「程序」旋鈕

- 開啟洗衣乾衣機並選擇所需的程序。
- 如有需要調整洗衣溫度，然後按所需的“選項”按鈕。

乾衣

如果您希望在洗衣程序後，自動開始乾衣程序，請按「乾衣選項」鍵，以選擇所需的程序。或者您可以完成洗衣程序後，然後選擇乾衣程序和加載的大小。

- 按「啟動/暫停」鍵，以開始洗衣程序。
- 程序完成時，顯示器上顯示程序結束「END」或於某些型號上，所有洗衣階段指示燈都會亮起。

打開機門之前，請等待「機門鎖上」指示燈熄滅。

- 關閉洗衣乾衣機。

對於不同類型的衣物，請參閱「程序表」，並根據顯示的次序操作。

供水數據資料表

水壓：

最低 0.05 Mpa / 最高 0.8 Mpa (0.05 MPa 表示在 10 秒內分配大約 1 升的水)

脫水轉速：請參閱銘牌上的資料。

電源輸入/電流保險絲/電壓：請參閱銘牌上的資料。

控制說明

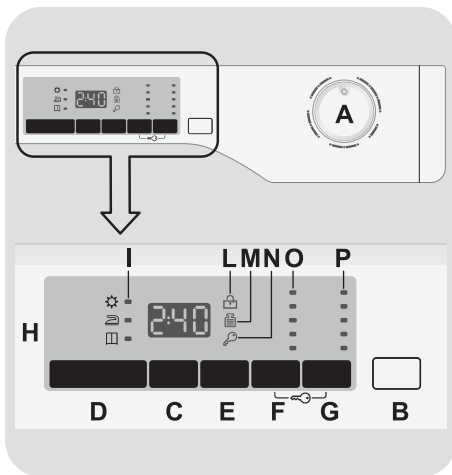

- A 「程序」旋鈕
- B 「啟動/暫停」鍵
- C 「預校開機時間」鍵
- D 「乾衣選項」鍵
- E 「快速/超強去漬」鍵
- F 「溫度」鍵
- G 「脫水轉速」鍵
- F+G 「兒童安全鎖」功能
- H 顯示屏
- I 「自選乾衣選項」指示燈
- L 「機門鎖上」指示燈
- M 「衣物重量負載偵測」指示燈
- N 「兒童安全鎖」指示燈
- O 「溫度」指示燈
- P 「脫水轉速」指示燈

「程序」旋鈕

當「程序」旋鈕轉動時，顯示屏亮起，顯示所選程序的設定。

為了慳電節能，在程序結束或休止狀態期間，顯示屏的亮度將會降低。

如要關閉本產品，請轉動「程序」旋鈕至向上「OFF」的位置。

- 按「啟動/暫停」鍵，開始選擇程序。
- 以「程序」旋鈕選擇所需要的程序，在所選程序上保持靜止，直到程序結束。
- 當程序結束後，顯示器上顯示程序結束「End」及「機門鎖上」指示燈會熄滅，您可以打開機門，及可以拿出機內衣物。
- 「程序」旋鈕扭回向上「OFF」的位置，以關閉洗衣乾衣機。

「程序」旋鈕必須在每個程序結束時返回到向上「OFF」的位置，或在下一個程序被選擇和啟動之前，必須啟動一個隨後的洗衣程序。

「啟動/暫停」鍵

在選擇「啟動/暫停」鍵之前，請關閉機門。

- 以「程序」旋鈕選擇程序

當按下「啟動/暫停」鍵時，機器可能需要幾秒鐘才能開始正常運作。

程序開始之後，添加或取走衣物 (暫停)

- 按住「啟動/暫停」鍵約 2 秒鐘 (某些指示燈和剩餘時間指示燈會慢慢地閃爍，表示機器已暫停)。
- 在打開機門之前，請等待「機門鎖上」指示燈熄滅。

在打開機門之前，請檢查水位是否在機門開口以下的位置，以避免水從滾桶流出。

- 添加或移除衣物後，關閉機門及按下「啟動/暫停」鍵，原有的程序會從新開始啟動。

取消正在運行的程序

- 如需要取消程序，將「程序」旋鈕轉至向上「OFF」的位置。
- 等待 2 分鐘，直到安全裝置解開門鎖。

「預校開機時間」鍵

- 按「預校開機時間」鍵，可預設延遲洗衣開始的時間。最長可達 24 小時。
- 延遲洗衣程序開始方法如下：
 - 選擇所需的程序
 - 按一下「預校開機時間」鍵，以啟動程序 (顯示屏顯示“h00”) 然後再按一次「預校開機時間」鍵，以設定 1 小時延遲 (顯示屏顯示“h01”)，每次按下按鈕時，預設延遲會加 1 小時，直到顯示屏上出現“h24”，此時再次按下按鈕，把延遲開始重置為“0”。

- 按「啟動/暫停」鍵，以確認啟動程序，「預校開機時間」倒數計時便會開始及當倒數計時完成後，程序將自動啟動。
- 如需要取消「預校開機時間」，將「程序」旋鈕轉至向上「OFF」的位置。以關閉功能。

如果洗衣乾衣機正在運行時電源中斷，特有的記憶功能會儲存已選擇的程序和在電源恢復時，程序會選擇在中斷時正運行的程序接著開始。

要按下「啟動/暫停」鍵，才可按「選項」鍵，如果選擇與所選程序相互不兼容，選項指示燈會先閃爍，然後熄滅。

「乾衣選項」鍵

- 洗衣或乾衣程序：

根據洗衣類型，選擇洗衣程序後，按下「乾衣選項」鍵，以選擇指定的乾衣程度。在洗衣程序結束時，所選擇的乾衣程序會自動開始。

如果洗衣程序與自選乾衣程序相互不兼容，則不會啟動此功能。

如果超過「程序表」中指定的最大乾衣負載量，衣物的乾衣效果，可能不佳。

如果要在程序啟動前，刪除已選的項目，請不停重覆按下相關選項鍵，直到閃燈熄滅或將「程序」旋鈕，重新轉動至向上「OFF」的位置。

- 獨立乾衣程序：

配合所需的衣物的類型，通過旋鈕選擇所需的乾衣程序，通過按下「乾衣選項」鍵，可以選擇不同的乾衣程度，此功能有別於預設的乾衣程序(羊毛乾衣程序除外)。

- 如需要在自選乾衣選項中，取消運行程序，請按下「乾衣選項」鍵，約 3 秒鐘。

 警告：取消乾衣程序後，開始冷卻階段，請等待約 10/20 分鐘才能打開機門。

- 程序完成時，顯示器上顯示程序結束「END」，「機門鎖上」指示燈會熄滅，您可以打開機門，及可以拿出機內衣物。

• 也可以通過將「程序」旋鈕轉至向上「OFF」的位置來取消乾衣程序。同時，必須等待冷卻階段結束 (10/20 分鐘)，「機門鎖上」指示燈會熄滅，您可以打開機門，及可以拿出機內衣物。

「快速 / 超強去漬」鍵

此按鍵讓您根據所選程序，在兩種不同的選項之間，進行選擇。

- 「快速」

- 當您在「程序」旋鈕上選擇「快速」(14/30/44分鐘)鍵時，程序便會啟動，並允許您選擇三個時間當中的其中一個時間。

- 「超強去漬」

- 當程序被選擇，所選程序的洗衣時間會自動顯示在顯示屏上。
- 此功能允許您選擇3個級別的洗衣強度，而程序的長短，則取決於衣物被污染的程序多少而決定(功能僅限於某些程序上適用，請參閱〈程序表〉所示。

「溫度」鍵

- 按下「溫度」鍵，允許您更改洗衣程序的溫度。
- 為避免衣物受損，請勿提高至程序的最高溫度。
- 如果要進行冷水洗程序，所有指示燈都必須關閉。

「脫水轉速」鍵

- 按下「脫水轉速」鍵，可以降低最高的轉速速度，如有需要，可以取消「脫水轉速」程序。
- 如果標籤上沒有指定的信息，則可以使用程序中預期的最高轉速。

為了避免令衣物受損，請勿增加程序中允許的最高轉速。

要重新啟動「脫水轉速」程序，按下「脫水轉速」鍵，並設置到所需的轉速速度。

- 可以在不暫停運作的情況下，修改脫水轉速的速度。

過量的洗衣劑會引起過量的泡沫。如果產品檢測到存在過多的泡沫，它可能排除脫水階段或延長程序的持續時間而增加耗水量。

本產品配有專有電子設備，防止脫水程序進行時而出現負載衣物不平均的情況。這減少本產品的噪音和震動，從而延長了本產品的耐用性。

兒童安全鎖

- 同時按下「溫度」鍵及「脫水轉速」鍵約 3 秒鐘的時間，表示按鍵已被鎖定，如果在程序進行期間，可避免意外按下顯示屏上的按鈕或不必要的更改。
- 解除鎖定控制面板，只需要再次同時按下「溫度」鍵及「脫水轉速」鍵約 3 秒鐘的時間，或關閉洗衣乾衣機來簡單地取消兒童安全鎖。

顯示屏

顯示屏的指示器系統可讓您不斷了解程序的階段及狀態。

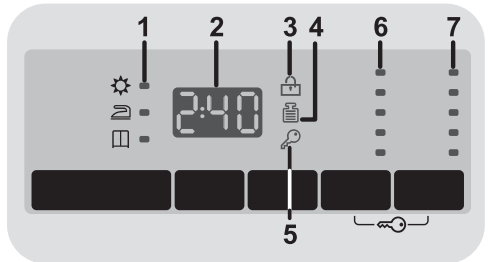

1) 自選乾衣指示燈

指示燈顯示相關按鈕，表示可選擇的乾衣程度：

- ☀ 額外乾衣
(適用於毛巾，浴袍和體積較大的衣物)
- ☹ 熨燙乾衣
(衣物仍略顯潮濕，以便於熨燙。)
- ☐ 一般乾衣
(足夠乾燥，將在乾衣程序結束後直接放入衣櫃，而不需使用熨燙。)

2) 程序時間

- 當選擇程序時，顯示屏會自動顯示程序原定的持續時間，這可能會因所選不同的選項而異。
- 在程序運轉的初始階段時，本產品會根據負載重量，衣物類型和選項來計算所需的實際程序時間。然後將所需的實際洗衣時間顯示。洗衣時間可以根據洗衣劑級別和平衡負載來重新調整。

3) 「機門鎖上」指示燈

- 在機門完全關閉時，指示燈亮起。

在選擇「啟動/暫停」鍵之前，請關閉機門。

- 機門關閉的情況下，按下洗衣乾衣機的「啟動/暫停」鍵，指示燈會瞬間閃爍，然後亮起。

如果未有正確關閉機門，指示燈將持續閃爍約 7 秒鐘，完成相關指令，閃爍將自動取消。在這種情況下，請以正確方式關閉機門，然後按「啟動/暫停」鍵。

- 打開機門之前，請等待「機門鎖上」指示燈熄滅。

4) 衣物重量負載指示燈 (功能僅限於某些程序上適用)

- 在洗衣程序中最初的一分鐘時間，「衣物重量負載偵測」指示燈會亮起，此時，智能感測器將對衣物進行重量感測，並相應地調整程序時間，水流和電量消耗。
- 在每個洗衣階段，洗衣程序中最初的一分鐘內會進行衣物重量負載偵測：
 - 調整所需的水量；
 - 確定洗衣程序的持續時間；
 - 根據所選擇洗衣的衣物類型來控制過水程序；
 - 根據洗滌衣物的類型；調節滾桶旋轉的速度。
 - 如出現過多的泡沫存在，必要時，調整過水量。
 - 根據負載重量調整旋轉速度，避免任何不平衡的旋轉。

5) 「兒童安全鎖」指示燈



- 指示燈亮起，表示控制面板即被鎖定。

6) 「溫度」指示燈

- 指示燈亮起，顯示所選程序的洗衣溫度。亦可以通過相關按鈕。如果需要進行冷水洗，所有指示燈都會熄滅。

7) 「脫水轉速」指示燈

- 指示燈亮起，顯示所選程序的旋轉速度，可以通過相關按鈕減低轉速。

最大負載量7公斤								洗衣劑和添加劑		
程序	溫度 °C	最高脫水轉速 轉/分鐘	乾衣選項	超強去漬功能	最大洗衣量 (公斤)	最大乾衣量 (公斤)	預設程序時間	預洗	主洗	柔順劑
										
棉質	冷水-90°C	1200	✓	✓	7	5	2:49	-	●	○
棉質與預洗	冷水-60°C	1200	✓	✓	7	5	3:02	●	●	○
e 棉質節能	冷水-60°C	1200	✓	✓	7	5	3:21	-	●	○
慳電20°	冷水-20°C	1000	-	-	7	5	1:36	-	●	○
合成纖維	冷水-60°C	1000	✓	-	3.5	-	1:55	-	●	○
纖細衣物	冷水-40°C	400	-	-	2.5	-	0:54	-	●	○
過水	-	1000	-	-	-	-	0:28	-	-	○
脫水	-	1000	-	-	-	-	0:10	-	-	-
排水	-	-	-	-	-	-	0:04	-	-	-
快速 14'	冷水-30°C	1000	-	-	1	-	0:14	-	●	○
快速 30'	冷水-30°C	1000	-	-	2.5	-	0:30	-	●	○
快速 44'	冷水-30°C	1000	-	-	3.5	-	0:44	-	●	○
襯衣	冷水-30°C	1000	-	✓	3.5	-	1:15	-	●	○
羊毛	冷水-40°C	800	-	-	1	-	0:48	-	●	○
手洗	冷水-30°C	800	-	-	1	-	0:48	-	●	○
合成纖維乾衣	-	-	-	-	3.5	-	2:50	-	-	-
棉質乾衣	-	-	-	-	5	-	3:50	-	-	-

● 需要使用洗衣劑 ○ 選擇性使用洗衣劑

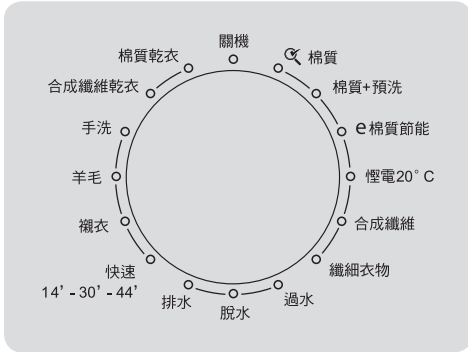

實驗室參考資料(參考 EN 50229 標準)

洗衣

此為能源標籤測試程序**選擇最大的「超強去漬」程度，最高轉速和60°C 的溫度。亦可使用較低的溫度作測試。

乾衣

首次乾衣操作載入 A 公斤衣物(衣物包括：枕袋及抹手巾) 並選用「棉質乾衣」程序下之(棉質乾衣) 一般乾衣程序。

若需要再次乾衣，第二次乾衣操作載入 B 公斤衣物 (衣物包括：床單 2 張及抹手巾)，並選用「棉質乾衣」程序下之(棉質乾衣) 一般乾衣程序。

洗衣量(公斤)	A (公斤)	B (公斤)
	首次乾衣	第二次乾衣
7	5	2

請閱讀下列注意事項：

- * 乾衣最大的負載量是根據產品的型號所定詳情請參閱〈程序表〉篇章。
- 當程序已被選擇時，顯示屏會顯示建議的洗衣溫度，如允許自選溫度時，可以通過按鍵來減少。
- 對於顯示的程序，您可以使用「超強去漬」鍵來調節洗衣的持續時間和強度。
- 在「程序」旋鈕上選擇「快速」程序，可以使用「快速」鍵來選擇14’，30’和44’，在三個時間當中，選擇其一。
- 自選乾衣程序。

程序

為了清洗不同類型的衣物和各種污垢，洗衣乾衣機具有特定的程序來滿足每一種洗衣的需要 (請參閱〈程序表〉)。

洗衣

棉質

適用於深層洗衣。在最後階段的脫水程序以最高的轉速旋轉，可以更有效的清除污漬。

棉質+預洗

此程序旨在消除棉質白色衣服更強的污漬。預洗可保證能去除強頑污垢。注入預洗格一定量的洗衣劑等於主洗用量的 20%。

e 棉質節能

適用於一般骯髒的棉質衣物。它是洗滌棉質衣物當中，綜合能源和用水量消耗方面的最有效的方法。

慳電 20°

這項創新的程序可讓用家將多種不同類型和顏色的衣物，例如棉質、合成纖維和混合衣物，以攝氏 20 度一同清洗，而且洗衣效果出眾。使用本程序的耗電量，僅為一般以攝氏 40 度使用棉質程序所需的 40%。

合成纖維

洗衣桶的旋轉規律和注水量經過精心計算和調節，令主洗及過水操作發揮出最佳的洗衣效果。溫和的脫水轉速可減少衣物起皺。

纖細衣物

該程序在洗衣程序期間減少了滾筒的旋轉方式，建議用作處理十分纖細的衣物。洗衣及過水會配合較高注水量進行操作，以確保達至最佳的效果。

過水

本程序包括三次過水操作 (操作時間可透過適當按鍵步驟自行縮短甚至取消)。本程序適用於處理任何類型的衣物，例如用於手洗衣物之後。

脫水

本「脫水」程序會以最高轉速操作 (亦可透過適當按鍵步驟自行調減)。

排水

本程序僅將水排出洗衣乾衣機。

快速 (14/30/44 分鐘)

洗衣程序建議適用於低負載量和稍微髒污的衣物。在這個程序，建議減少通常使用的洗衣劑的數量，以避免不必要的浪費。選擇「快速」程序並按下，您可以在三個時間當中，選擇其一。

襯衣

洗衣程序被優化，以減少摺痕的產生，保持良好的洗衣性能。還可以進一步降低旋轉速度，以確保更容易熨燙。

羊毛

此程序適用於洗衣程序，可在洗衣乾衣機中清洗的羊毛織物，或用於手洗的物品。

手洗

程序只能進行手洗程序，過程是以 3 次過水程序和以慢速旋轉完成。

⚠ 警告：假如使用儲放濃縮洗衣粉或洗衣液的洗衣球，在啟動烘乾程序之前，請先將洗衣球從洗衣桶取出。

滾桶在乾衣程序期間以不同方向轉動，以防止衣物在烘乾期間，產生皺摺情況。

散熱程序會在乾衣程序最後階段的10或20分鐘，洗衣乾衣機會利用涼風以令衣物減少起皺。

合成纖維乾衣

低溫乾衣

程序適用於合成纖維及混合衣物(有關衣料成份請參閱衣物上之標籤。)

棉質乾衣

高溫乾衣

程序適用於棉質及尼龍衣物(有關衣料成份請參閱衣物上之標籤。)

乾衣程序

- 使用本產品可助您的衣物達到最佳的乾衣效果。
- 在首次使用本產品，以確定所需的乾衣程度時，我們建議設定於標籤指示為低的乾衣時間。
- 我們建議不要為易破損的衣物進行乾衣。一些長織物，由於在處理過程中容易造成喉管阻塞，也應避免進行乾衣操作。
- 我們建議您通過以下方法對洗衣進行排序：

- 根據衣物標籤的符號選擇乾衣護理程序：

- 適用於洗衣桶烘乾。
- 在高溫下烘乾。
- 僅在低溫下洗衣桶烘乾。
- 不適用於烘乾。

如果衣物上沒有標示任何的護理標籤，您應該假設為不適合進行乾衣程序。



- 按尺寸和厚度
每當洗衣量大於乾衣容量時，請根據厚度將衣物分離 (例如：毛巾應從內衣衣物中取出分隔)。
- 按衣物類型
棉質/床單：毛巾，棉布，床單和桌布。
合成纖維：由聚酯或聚酯胺製成的襯衫，襯衫，工作服，以及棉質/合成纖維混合物。
- 限於烘乾已清洗的衣物。

正確的乾衣方法：

- 打開機門。
- 放入衣物，不可超過〈程序表〉中指定的最大乾衣量。如有大型物品(如床單)或吸水性較強衣物(如、牛仔布衣物)，最好的方法是減少負載。
- 關上機門
- 轉動「程序」旋鈕，為衣物選擇最合適的乾衣程序。

此洗衣乾衣機可進行以下的乾衣種類：

- 合成纖維乾衣：乾衣程序建議適用於(合成纖維及混合衣物)
(“合成纖維乾衣”會顯示於「程序」旋鈕上)
- 棉質乾衣：乾衣程序建議適用於棉質、毛巾類衣物、亞麻織物、大麻布及床單等。
(“棉質乾衣”符號會顯示於「程序」旋鈕上)
- 選擇所需的乾衣程度：

-  額外乾衣
(適用於毛巾，浴袍和體積較大的衣物)
-  熨燙乾衣
(衣物仍略顯潮濕，以便於熨燙。)
-  一般乾衣
(足夠乾燥，將在乾衣程序結束後直接放入衣櫃，而不需使用熨燙。)

- 洗衣乾衣機將根據所選的負載量和乾衣的類型來計算乾衣所需的時間和衣物中剩餘的水分含量。
- 檢查水龍頭是否打開，排水軟管是否正確放置

⚠ 警告：切勿為羊毛衣物或附軟墊的物品(例如縫製被、縫製外套等)進行乾衣。

假如屬纖細衣物，請以晾乾處理，並負載較少量衣物清洗，以防起皺。

- 按「啟動/暫停」鍵(顯示屏將顯示剩餘的乾衣時間)。

本產品會根據標準的負載量來計算所選的程序結束的時間。在程序中，本產品會根據負載量的大小來校正時間。

在乾衣操作期間，洗衣桶速轉將高於正常，目的是讓衣物平均分佈，以提升乾衣功效。

- 程序完成時，顯示器上顯示程序結束「END」，約 5 分鐘後，洗衣乾衣機將進入待機模式(在某些型號上，顯示屏將顯示 "--")。
- 將「程序」旋鈕轉到向上「OFF」的位置以關閉洗衣乾衣機。
- 打開機門並取出衣物。
- 關閉水龍頭

取消正在運行的乾衣程序

- 要取消乾衣程序，請按「乾衣選項」鍵約 3 秒鐘。

⚠ 警告：取消乾衣程序後，將進行冷卻階段，您必須等待約 10/20 分鐘才能打開機門。

為了確保本產品的正常運行，如非必要，建議不要中斷乾衣階段。

自動洗衣/乾衣操作

您不可負載超過〈程序表〉中指定衣物的最大乾衣負載量，否則衣物不能達到最佳的乾衣效果。

- 洗衣

- 打開洗衣劑盒，並放入適量的洗衣劑。
- 請參閱清洗衣物的〈程序表〉(例如：非常髒的棉布)，並將「程序」旋鈕轉到所需程序。
- 如有需要，請調整洗衣溫度。
- 如有需要，請按選項鍵。
- 檢查水龍頭是否已打開，排水軟管是否正確放置適當的位置。

- 乾衣

- 選擇所需的乾衣程度
 - ☆ 額外乾衣
(適用於毛巾，浴袍和體積較大的衣物)
 - ☰ 熨燙乾衣
(衣物仍略顯潮濕，以便於熨燙。)
 - ☐ 一般乾衣
(足夠乾燥，將在乾衣程序結束後直接放入衣櫃，而不需使用熨燙。)
- 按「啟動 / 暫停」鍵
- 洗衣階段結束時，顯示屏將顯示剩餘的乾衣時間。
- 程序完成時，顯示器上顯示程序結束「END」，約 5 分鐘後，洗衣乾衣機將進入待機模式(在某些型號上，顯示屏將顯示 "--")。

- 將「程序」旋鈕轉到向上「OFF」的位置以關閉洗衣乾衣機。
- 打開機門並取出衣物。
- 關閉水龍頭

取消正在運行的乾衣程序

- 要取消乾衣程序，請按「乾衣選項」鍵約 3 秒鐘。

 **警告：**取消乾衣程序後，將進行冷卻階段，您必須等待約 10/20 分鐘才能打開機門。

為了確保本產品的正常運行，如非必要，建議不要中斷乾衣階段。

故障排除及日常保養

該洗衣乾衣機可能因為某些原因而不能正常運作。聯絡售後服務中心之前，建議先自行進行檢查，看問題是否可以使用以下列表的簡易方法解決。

故障代碼格式

- **設有顯示屏的型號**：如發生故障，字母“E”會顯示在數字的前方，(例如: E2 = Error 2)。
- **沒有顯示屏的型號**：如發生故障，每個 LED 按鍵均會連續閃爍，錯誤代碼會依據閃爍的次數而決定，而閃爍後會暫停 5 秒鐘，以顯示發生錯誤 (例如: 閃爍 2 次- (暫停 5 秒鐘), (重覆步驟), 再次閃爍 2 次-(暫停 5 秒鐘) = Error 2)。

顯示信息	可能的原因和解決方案
E2 (有顯示屏) LED 燈閃爍 2 次 (沒有顯示屏)	洗衣乾衣機無法進水。
	確保水龍頭開啟。
	確保進水喉沒有阻塞或扭曲。
	確保排水喉安裝於適當的高度(請參閱〈安裝指南〉篇章)。
	關閉水龍頭，擰下洗衣乾衣機後方的進水管及確保過濾網乾淨，不堵塞。
E3 (有顯示屏) LED 燈閃爍 3 次 (沒有顯示屏)	洗衣乾衣機無法排水。
	確保過濾器沒有堵塞。
	確保排水管沒有阻塞或扭曲。
	確保家中的排水系統不被堵塞和允許積水流過而沒有阻塞。盡量排走積水於水盆內。
E4 (有顯示屏) LED 燈閃爍 4 次 (沒有顯示屏)	有太多的泡沫和/或水。
	確保使用的洗衣劑劑量正確和專為洗衣乾衣機而設的洗衣劑
E7 (有顯示屏) LED 燈閃爍 7 次 (沒有顯示屏)	機門問題。
	確保機門正確關閉。確保滾桶內的衣服沒有阻外機門完全關上。
	如果機門被鎖定，請關閉並從電源插座上拔下洗衣乾衣機，等待 2-3分鐘並重新打開機門。
其他故障代碼	關閉洗衣乾衣機電源並拔下電源插頭。約一分鐘後，重新啟動洗衣乾衣機。如果故障仍然存在，請聯絡我們的售後服務中心。

其他異常情況

問題	可能的原因和解決方案
洗衣乾衣機無法啟動。	確保插頭正確插於插座內。
	確保電源已連接並開啟。
	確保牆上的插座正常運作，以其他家電進行測試(如：燈)
	洗衣乾衣機門沒有完全關上；打開並再次關閉上。
	檢查所選的程序是否正確被選擇，並按下「啟動/暫停」鍵，以確認程序。
確保洗衣乾衣機並不處於待機或「預校開機時間」模式。	
洗衣乾衣機附近地板有積水	水龍頭與進水管之間密封圈出現滲漏；在這種情況下，請更換並正確擰緊進水管連接。
	確保前方的過濾器已正確關閉。
洗衣乾衣機無法脫水。	此機器配備一個檢測系統，如果在脫水之前，洗衣桶內衣物分佈不平均，則可以保護洗衣桶負載和衣物免受損壞。這可能導致以下情況：
	<ul style="list-style-type: none"> • 將衣物重新平均分佈於洗衣桶內，增加脫水時間。 • 減低轉速，減少震動和噪音。 • 中止脫水程序，以保護機器和加載效能。
	如果這是常發生的情況，請卸下負載的衣物，並將其重新載入洗衣桶內，然後重新啟動「脫水」程序。
	可能是因為洗衣乾衣機的積水沒有被完全排出；等候數分鐘待積水排走，如果故障仍然存在，請參看「故障排除」中「Error 3」的篇章。
	某些型號包括「不脫水」功能：請確保沒有選擇此功能。
檢查哪些選項，一旦被選擇，會對「脫水」程序有所影響。	
過量的洗衣劑會阻礙「脫水」程序，確保使用正確劑量的洗衣劑。	
脫水時機身震動。	洗衣乾衣機可能放置水平不理想；如有必要，請按照指定篇章所示，調整機腳。
	確保搬運螺栓，橡膠圈和定位膠墊被取下。
	確保沒有會損毀洗衣桶的異物（如銀幣、扣針、鉸鏈等）。

製造商的保養範圍主要覆蓋由本產品製造過程有可能產生的技術故障。如發現故障是由製造商的製造過程以外的成因造成，如：不當地使用或不遵守使用說明，製造商可能會收取額外費用。

操作洗衣乾衣機時使用不含磷酸鹽的環保洗衣劑可能會產生下列現象：

- **過水操作後排走的水呈較混濁狀態：**

原因是水中含有懸浮的沸石，但這現象並不會影響過水的效果。

- **清洗後的衣物表面會出現白色粉末(沸石)：**

這屬於正常情況，原因是沸石不會被衣物纖維吸收，但這些粉末不會影響衣物的顏色。要去除沸石，請使用一個過水程序。在日後進行洗衣時，考慮使用較少劑量的洗衣劑。

- **在最後的過水程序，水中出現泡沫：**

這並不代表過水效果欠佳。只是在日後進行洗衣時，考慮使用較少劑量的洗衣劑。

- **大量泡沫：**

由於洗衣劑成份中的負離子表面活性劑難以從衣物中清除的情況經常會發生，在這種情況下，即使衣物中的負離子表面活性劑含量極少，也能造成大量泡沫。

- 在這種情況下，即使重複進行過水程序，亦無法杜絕上述情況出現。

我們建議使用專用的清潔劑進行護理及清洗。

如果問題仍然存在，或者懷疑發生故障，請立即聯絡我們的售後服務中心。

建議使用我們授權的售後服務中心，以確保適當的維修和使用原廠零售配件。

保養

產品會根據附帶的〈保養登記卡〉中規定的條款和細則作為保證。〈保養登記卡〉必須妥善填寫並儲存，以便在有需要時向授權的售後服務中心出示。購買證明必須在保養及維修產品時提供。

製造商對本產品附帶的小冊子中的任何打印錯誤負責。此外，製造商保留對因產品進行任何更改的權利，而不變更其基本特徵。

安裝指南

- 從機器背後的固定夾上鬆開電源和排水喉。
- 拆下背面的 2 或 4 個運輸螺絲 (A)，拆下 2 個或 4 個平墊圈，保護塞和定位膠墊 (B)，如圖 1 所示。
- 如果是內置式洗衣乾衣機，擰下 3 或 4 個運輸螺絲 (A) 並拆下 3 或 4 個平墊圈，保護塞和定位膠墊 (B)。
- 拆除螺絲時，另一個定位膠墊將跌落在機身內側。將機身傾斜，便可取走上述定位膠墊。並從機架的底部或機身的內部收回定位膠墊。
- 利用附帶於操作指南包裝內的 4 個螺孔保護塞，覆蓋機身背部 4 個螺絲孔。



切勿將包裝棄置於小童可觸及的地方，以免造成危險並釀成意外。

如圖 2 所示，將隔音墊 (可於拆卸包裝時，在設備頂部位置找到)，放置於機腳下方。(根據型號，參考 A, B 或 C 版本)。

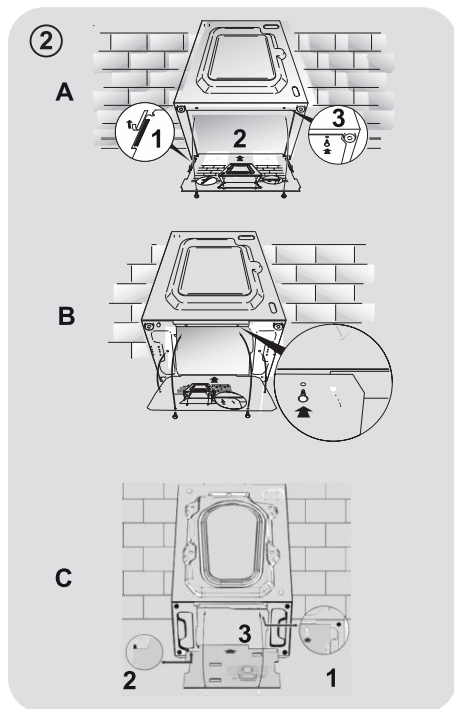
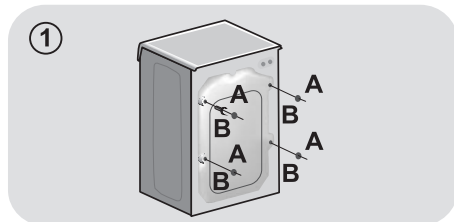

如何將洗衣乾衣機安裝在櫃檯下

- 將洗衣乾衣機推入大小適合的位置(於圖中所示相反的方向)。

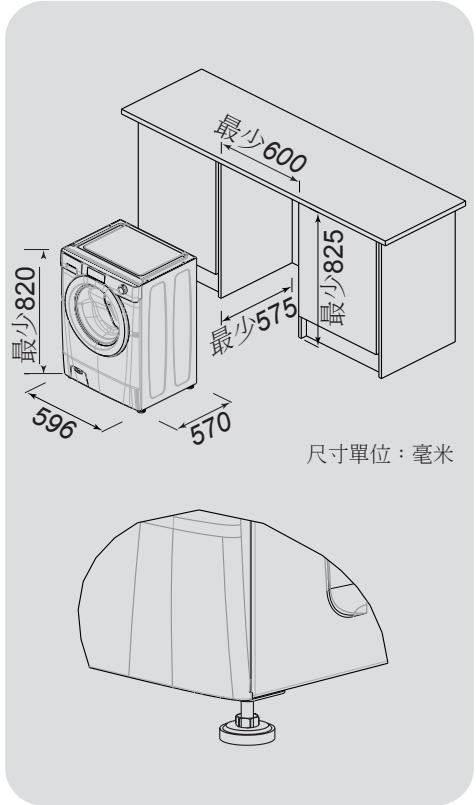

接駁水管

- 本產品必須使用全新的喉組接駁主要供水裝置 (如圖 3)。舊的喉組不應重複使用。
 - 視乎不同的型號可能包括一個或多個以下的功能：
 - 熱水和冷水供應 (圖 4)：
- 水管連接裝置連接冷水和熱水，可獲得更高的節能。將灰色管連接到冷水供應裝置，將紅色管連接到熱水供應裝置。此時，裝置只能連接到冷水供應裝置：在這種情況下，有些程序需要在幾分鐘後才能運行。
- 保險進水喉 (圖 5)：
- 如果進水喉出現劣化情況 (如變脆和爆裂)，則位於供應管上的裝置會停止水流；在這種情況下，安全閥檢視窗 (A) 如呈紅色，說明安全閥已經啟用，此時就必須更換進水喉。按下釋放按鈕 (B)，而擰開軟管。
- 三重防溢 — 保護供水管道 (圖 6)：
- 如果水從主內管 “A” 洩漏，透明容器 “B” 將含有水，並立即停止進水到洗衣乾衣機，當洗衣程序完成後，請聯繫客戶服務中心更換供應管。

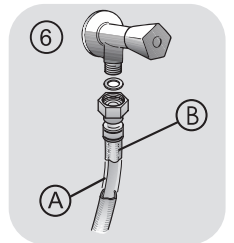
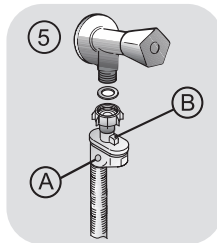
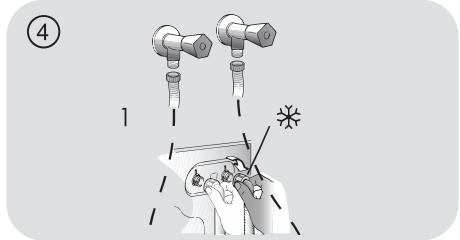
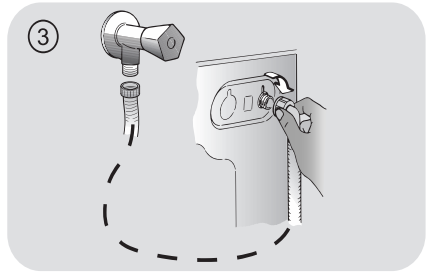

設置

- 洗衣乾衣機的安裝位置，需要讓進水管及排水管有足夠空間而不會被扭結。排水軟管必須放入 50 厘米至 85 厘米高的排水管内。切勿使用鋅盤下的排水管，必須把排水軟管放於鋅盤上，以防止虹吸。必須注意避免扭結或堵塞排水軟管 (圖 7)。

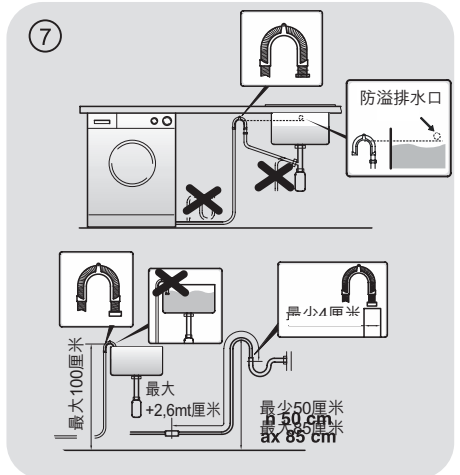

- 調校機腳以保持機身與地面成水平(圖8)：
 - a. 按順時針方向鬆開螺帽以便調校機
 - b. 以旋扭方法調整機腳高度，直至機定於地面上。
 - c. 按逆時針方向轉動前方機腳螺帽，螺帽緊貼機身底部。
- 插入電源插頭，啟動電器。

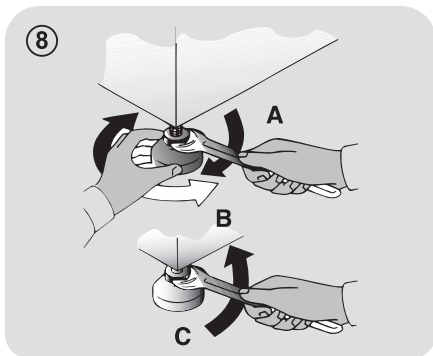

⚠ 警告：如果電源線需要更換，請聯繫客戶服務中心。

洗衣劑盒

將洗衣劑盒分為 3 個隔間 (如圖 9)：

- 主洗格：主洗用洗衣劑 (2)
- 柔順劑格 “☼”：如專用添加劑，衣物柔順劑，衣漿



⚠ 警告：
只可使用液體產品；洗衣乾衣機會設定在最後一次過水期間，於每個階段自動劑量添加劑。

- 預洗格：預洗用洗衣劑；(1)

⚠ 警告：
有些洗衣劑很難去除。在這種情況下，我們建議使用特定的容器放置在洗桶中(如圖10)。

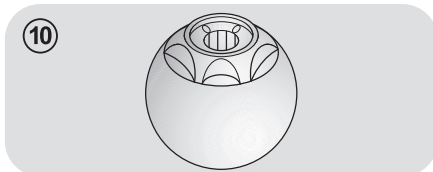

安裝簡圖

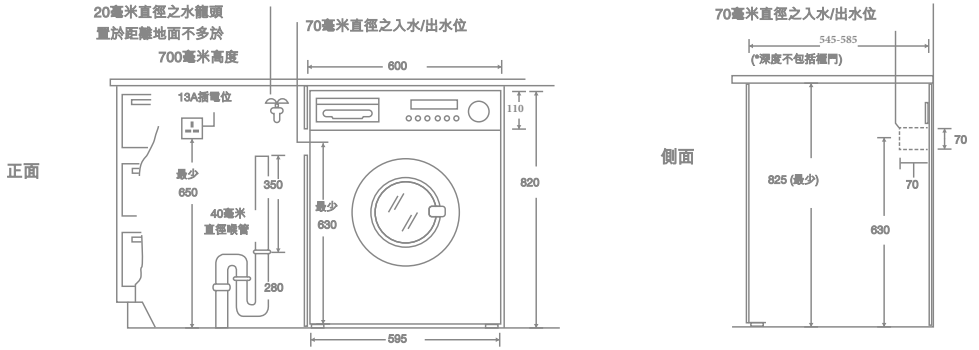

Whirlpool® Registered trademark/TM Trademark of Whirlpool group of companies
All rights reserved - <http://www.whirlpool.com.hk>

註冊商標/惠而浦集團的TM商標
版權所有 翻印必究 - <http://www.whirlpool.com.hk>



Whirlpool